

The information system for eliminating the multistorey buildings excessive tilt on loess soil

Bohdan Chorny

Zaporizhzhya Building Professional College, Ukraine, 050415@ukr.net

Andrey Shokarev

Research Institute of Building Constructions, Zaporizhzhya Branch, Ukraine

ABSTRACT: The foundation tilt is one of the criteria determining the building object operational suitability. Regulatory documents limit the permissible tilts values for buildings and structures. However, in many cases at the various stages of the building object life cycle, the foundation tilts exceed the permissible and even limit values. The information technologies and non-destructive testing experimental methods development allows solving the construction industry modern problems related to analyzing the multistorey buildings (MB) current technical state and forecasting its changes soon and in the future. At the same time, both in the short-term and in the long-term perspectives, the requirements are increasing with respect to the accuracy of the MB technical state changes forecasting, buildings direct connections with the problems of the territory where they are located, signals processing and visualization in the information systems for the excessive tilts elimination in the MB, base soil degradation consideration, territory flooding, increased seismic activity and global warming-related changes that are directly projected onto a given construction site, construction site or project location. All these issues require a systematic analysis of many influencing factors that were not taken into account earlier and a development of the new methods, precise sensitive elements and new information technologies capable of synthesizing all the mentioned problems. The "PENDULUM" program is intended for calculating and visualizing the MB civil structures displacements. The measuring and monitoring system advantages are as follows: the tilts measurement in the 360° azimuth plane; the possibility of obtaining a large number of measurements during a short period of time with a measurement interval from 1 hour to 8760 hours; the measurements accuracy increase in average from 9 measurements with normalization according to the standard inductance, etc.

KEYWORDS: Tilt, Technical state, Inclinometer, Identification, Risk, Drilling method.

1 INTRODUCTION

The development of information technologies and non-destructive testing experimental methods allows solving the modern problems of the construction industry related to analyzing the multi-storey buildings current technical state and forecasting its changes soon and in the future. The issues of the theoretical and methodological basics and instrumental means development for creating and using information technologies in various fields of human activities, fault tolerance, information technologies and systems survivability, models and methods development for decision-making under the risk and uncertainty conditions when creating the various-purpose automated systems were actively studied by I. Sergienko, O. Trofymchuk, O. Khimich and others (technologies and systems for decision support under the uncertainty conditions); (Trofymchuk, 2022, 2024, 2025), (nonlinear systems analysis); (Kaliukh, 2011, 2018, 2019) (construction of decision support systems), (Zaychenko, 2016, 2019), (methods of fuzzy analysis and modeling); (Pankratova, 2022) (methods of complex systems modeling); (Shokarev, 2020, 2021), (Banakh, 2025), (Slyusarenko, 2025), (decision support systems, etc.) and others.

The software development and implementations for the instrumental information and analytical systems of managerial decisions support in the construction field using the LIRA-SAPR software system are presented in the works by (Marienkov, 2023, 2025), (Kaliukh, 2011, 2018, 2019) and (Berchun, 2023, 2024). The practice of equipping the construction objects with information technology in online mode is currently not characteristic of Ukraine, rather only some examples are known. The information systems development for construction objects monitoring is mainly influenced by the following factors: the technical ones relating to determining the physical and mechanical parameters, on which the measuring system is

based; the technological ones including the methods and means development for components manufacturing and systems installation and operation; the economic ones concerning the system price parameters optimization.

The permissible values of buildings and structures tilts (DSTU B V.2.6-156:2010, 2011) and (DSTU-N B.1.2-18:2016, 2017) are limited by regulatory documents. In order to assess the stress-strain state of the "base-foundation" system when eliminating excessive tilting, it is necessary to control various physical quantities and parameters, which leads to the necessity of using in the construction objects with information technology a large number of sensors. They are the primary measuring transducers differing in structure and principle of operation, for example, strain gauges or magnetoelastic and magnetostrictive sensors for the mechanical stress control; inductive and electromagnetic ones for the linear and angular displacements control; liquid ones to control the relative settlements and deformations of the buildings and structures bases.

2 AUTOMATED INFORMATION AND MEASUREMENT SYSTEM

The "Monitoring" automated information and measurement system is a key element of the construction objects with information technology and is designed to control in an online mode the directions and angles of the construction objects and their elements tilts for ensuring the safe elimination of the multi-storey buildings excessive tilting. Based on inductive transducers it supports the remote reading, processing and transmission of information from sensitive elements. The technical means included in the "Monitoring" information and measurement system are presented in Figure 1.



Figure 1. Technical means of the automated measuring and information system: 1 – inductance meter; 2 – sensor for measuring angular deformations; 3 – communication lines; 4 – unit for collecting and transmitting information to the cloud.

Information is transmitted by the mobile communication networks in the SMS messages form via the Internet to an e-mail mailbox or to any mobile phone with subsequent processing on a computer. The system operates in an automatic mode with the possibility of the activation period programming.

The operation is carried out from the ~ 220 V network with an uninterruptible power supply unit (1000 h - standby mode, 48 h - measurement mode). The mobile phone battery charge checking and entire system testing are automatically carried out every 12 hours, the course of time and the calendar are also monitored.

After interrogating the sensors (the measurement time of 99 sensors is 12 seconds), the system switches to energy-saving mode. In the process of the system development, an original inductance meter installed in the sensors was elaborated. The meter sensitivity is up to 0.5 μH with a measurement error of 0.2 % in the entire used range. At the same time, the displacement measurements accuracy is 0.001 mm, and the design error of the tilt determination is 0.05 %.

The information collection unit performs the following operations: power supplying to the system from the ~ 220 V network or from the built-in battery; charging the uninterruptible power supply unit battery; power supplying to the sensors via the communication line; collecting the information from sensors; mobile phone battery charging; controlling the mobile phone operation during the data transmission; all settings memorizing in a non-volatile memory; switching to the energy-saving mode in the pauses between operation cycles. The data collection unit is connected to the 220 V network and via the DB9 connector to the communication line. The brief scheme of the "Monitoring"

system installation on the multi-storey buildings is shown in Figure 2.

At the measurement moment the "Monitoring" information and measurement system supplies power to the communication line, and the sensors are sequentially interrogated. After all sensors interrogating the communication line is switched off and the "Monitoring" information and measurement system turns on the mobile phone and transmits the measurement results.

Then the mobile phone is turned off, the "Monitoring" information and measurement system switches to an energy-saving mode until the next moment of measurement. If in the communication line an overload is detected, the error message "Interface failure! Can't access to sensors" is automatically sent.

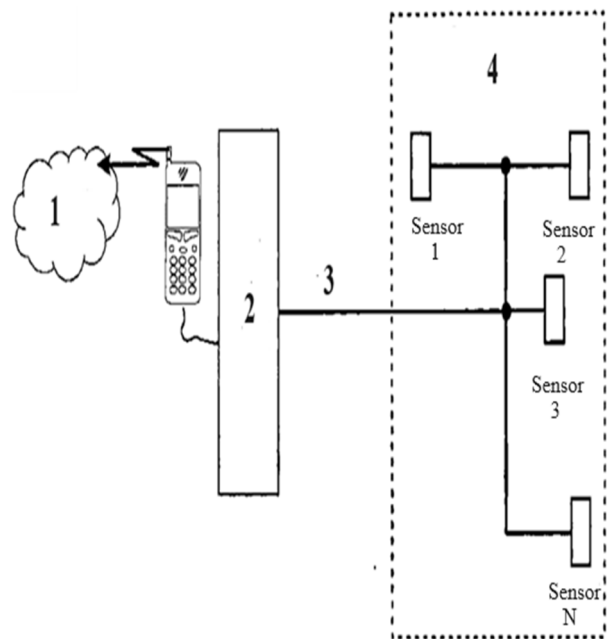

Figure 2. The brief scheme of the "Monitoring" system installation on the multi-storey buildings: 1 – Internet (e-mail); 2 – information collection unit; 3 – communication line; 4 – object of measurement (multi-storey buildings); 1, 2, 3, N – sensors.

The "Monitoring" information and measurement system switches to an energy-saving mode until the next measurement moment.

The external appearance of a universal inductive sensor with an inductance meter, installed in the basement of a tilted residential building in Zaporizhzhia, is presented in Figure 3.

The collection of information from precision inclinometric sensors (measuring tilt angles of structural elements) distributed throughout the building is facilitated by IoT (No. 4 in Figure 1 and No. 1, No. 2 in Figure 2).

Current experimental measurements of the stress-strain state and technical condition of the building are promptly processed and provided to decision-makers to determine whether alignment should continue or be suspended. Processing of these online results by the monitoring system initiates the following management actions:

(1) sequential adjustment of the digital model according to the calculated stress-strain parameters of the tilted building

using the LIRA-CAD software suite (Marienkov, 2023, 2024, 2025);

(2) comprehensive analysis of results to identify structural elements in critical states and, if needed, reinforcement measures suite (Titarenko, 2025), (Kaliukh, 2018, 2019);

(3) selection of technological methods for settlement adjustment based on the calculated stress–strain diagram;

(4) implementation of corrective measures when discrepancies arise between actual and projected parameters such as settlement or tilt.



Figure 3. The appearance of the universal inductive device sensor installed on a wall in the basement of the building.

3 "PENDULUM" PROGRAM

The "PENDULUM" program is intended for calculating and visualizing the multi-storey buildings civil structures displacements. The initial data for the program are composed of the "Monitoring" system construction objects with information technology measurements results taken from the angular deformations measuring sensors.

To determine the position of the angular deformations measuring sensor pendulum (Figure 1), a special numerical algorithm is developed. It searches for such pendulum position inside the square, for which the coils inductance values obtained by the inductance field model correspond as closely as possible to all four results of the given measurement. To determine the coil coordinates, it is necessary to set the basic measurement. The coil coordinates

are determined by the coil displacement along a line, which so connects a pair of opposite coils that the inductance obtained from the basic measurement is equal to the inductance obtained from the inductance field model. The pendulum coordinates in the basic measurement are assumed zero.

All further measurements give the pendulum position relative to the basic measurement. For the results displaying two following methods are suggested. The first method envisages marking the two measurements in a special way (Figure 4). Two displacement vectors should be created, namely from the basic measurement to the second marked one and from the first marked measurement to the second marked one.

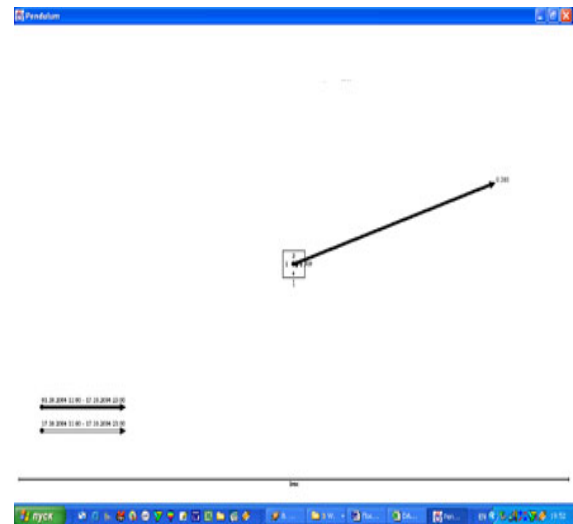

Figure 4. Visualization of the measurements results (method 1).

In the second method all necessary measurements are marked in a special way (Figure 5); a line connecting the pendulum positions for all marked measurements is drawn.

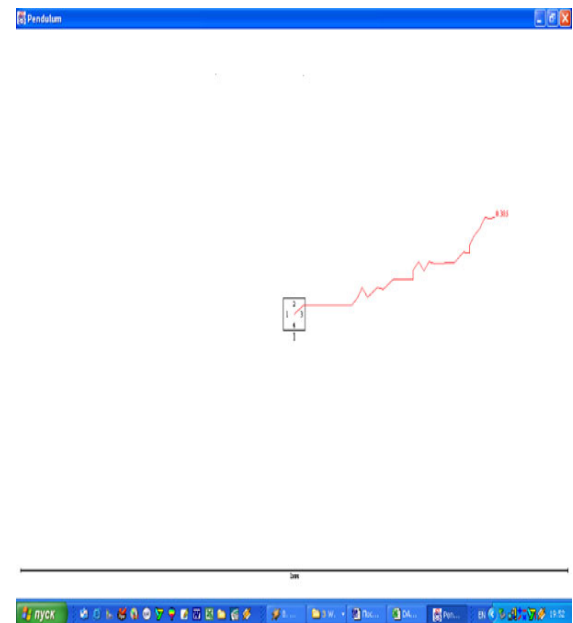

Figure 5. Visualization of the measurement results (method 2).

The initial data for the program are prepared in the MS Excel (Figure 6) and transferred to the program via the Clipboard.

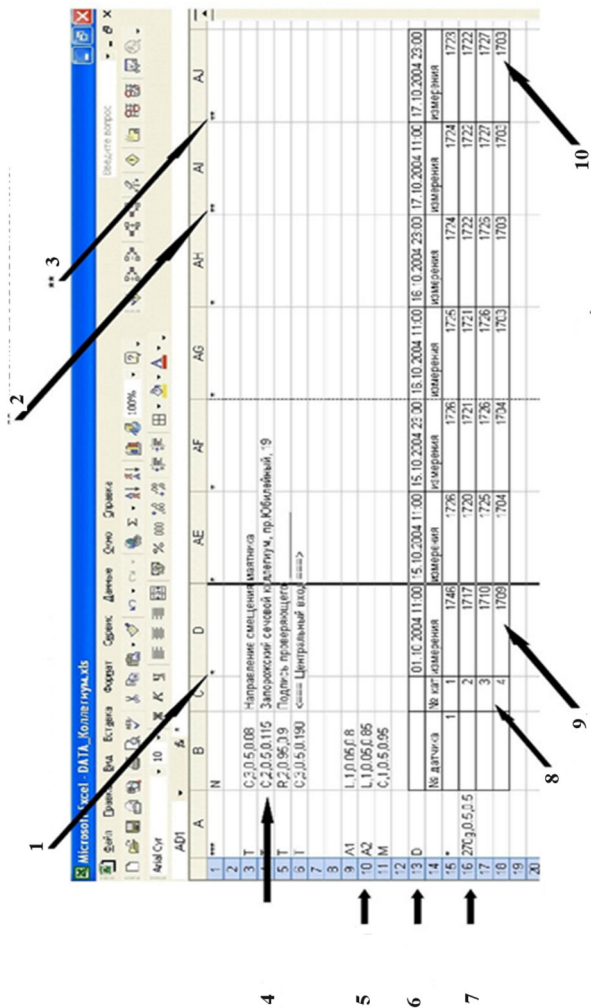

Figure 6. Output data of four inductances: 1 – basic measurement column; 2 – the last but one measurement column; 3 – the last measurement column; 4 – text information; 5 – information about the date of the last and previous measurement, scale; 6 – measurement date; 7 – orientation of the coils in the sensor and of the sensor on the object; 8 – coils numbers; 9 – basic measurement; 10 – the last measurement.

When displaying according to method 2, all marked measurements are used. At the same time, for each sensor the program displays a red line connecting the pendulum positions calculated for each measurement (Figure 4). By pressing the F1 key any of the methods can be selected or images of two methods can be combined (Figure 7).

It is possible to display on page an arbitrary number of sensors (Figure 8) installed on a given object or each one separately placing it in any convenient place on the page. Practical experience shows that if the number of sensors exceeds 10, they must be placed in groups on each page and moving to the next page must be performed with the Page Up or Page Down keys. The program constantly interrogates the Clipboard and, as

soon as its content changes, carries out the calculation and information displaying on the screen.

The following operation sequence is recommended: open simultaneously the Excel and the Pendulum program; make changes in the table by entering measurement data; "select all"; "copy"; switch to the Pendulum program. As a result, the changes will be immediately displayed on the screen. The P (Latin) or Z (Ukrainian) key shall be pressed to print the current page and Page Up or Page Down key to scroll through pages.

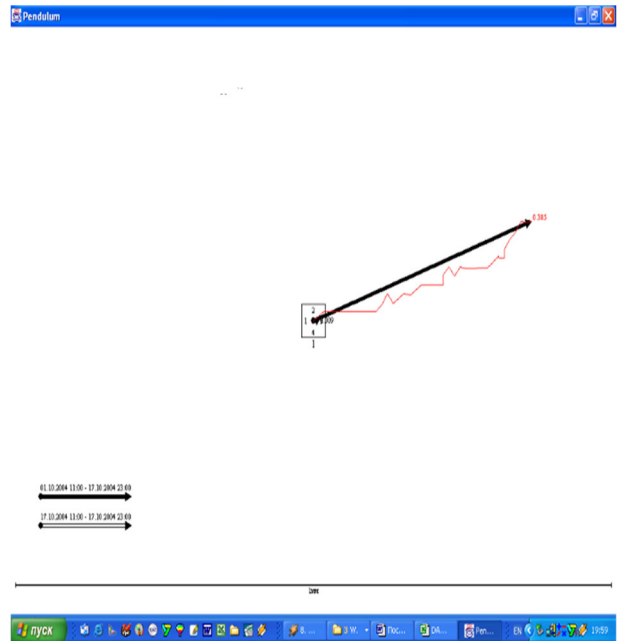

Figure 7. Measurements results visualization (method 1 + method 2).

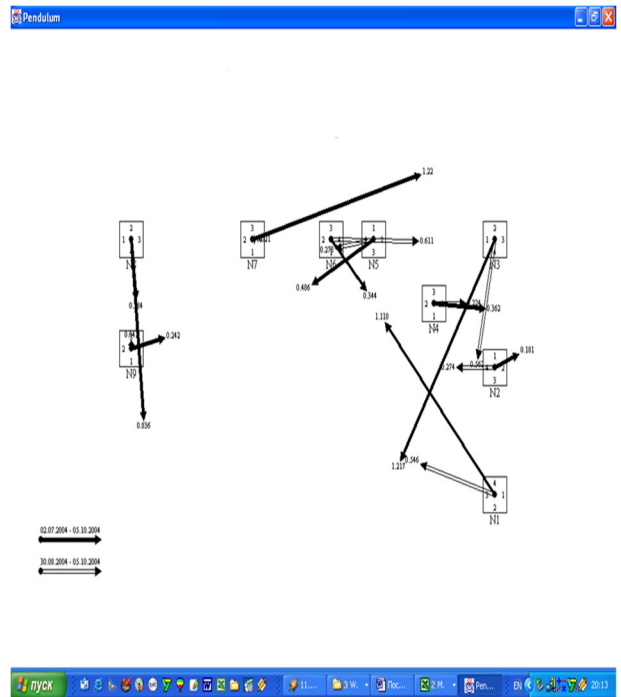

Figure 8. Visualization of measurement results for 9 sensors.

The cursor arrows shall be used to change the scale. At that the vectors arrow size will be changed in proportion to the scale size (at the bottom of the image).

In Figure 9. the general view of the expansion joint between the block sections No. 3 and No. 1 at 23 and 25 Preobrazhenska St. in the city of Zaporizhzhia is taken from the angular deformations measuring sensors of the "Monitoring" information and measurement system construction objects with information technology before and after leveling.



Figure 9. General view of the expansion joint between the block sections No. 3 and No. 1 at 23 and 25 Preobrazhenska St. in the city of Zaporizhzhia before and after leveling.

The results of signals processing and visualization by means of the Pendulum program have been taken into account to support the managerial decisions during the entire long time of the multi-storey buildings excessive tilt elimination at 23 and 25 Preobrazhenska St. in Zaporizhzhia.

The results of signals processing and visualization by means of the Pendulum program have been taken into account to support the managerial decisions during the entire long time of the multi-storey buildings excessive tilt elimination at 23 and 25 Preobrazhenska St. in Zaporizhzhia.

4 CONCLUSIONS

1. The measuring and monitoring system advantages are as follows: the tilts measurement in the 360° azimuth plane; the possibility of obtaining a large number of measurements during

a short period of time with a measurement interval from 1 hour to 8760 hours; the measurements accuracy increase in average from 9 measurements with normalization according to the standard inductance; the temperature influence elimination by means of the standard inductance installation in each sensor and the individual calibration; the possibility of information receiving remotely by a mobile phone (if an operational control is necessary) or from the Internet, which ensures the possibility of data obtaining if the sensors are installed in the hard-to-reach places; the preventive works possibility without removing the primary information sources and with the measurement legend preservation; lower cost compared to domestic and foreign analogues.

2. The model-based experiments show that the Pendulum program can determine the pendulum position according to three and two (non-opposite) coils. Therefore, a tool is introduced to exclude the coil from the calculation. To do this, it is necessary to set the coil inductance outside the permissible range of inductance, for example, 0. If the F2 key is pressed, the program additionally displays on the screen the service information about the last measurement (above the sensor), i. e., the so-called discrepancy.

3. The discrepancy is displayed in red above the sensor. The number characterizes how well the measured inductances agree with each other. The values from 0 to 4 can be regarded as the measurements errors (in μH). If the value exceeds 4, then most likely one of the inductances was measured incorrectly.

4. If two opposite coils are excluded from the calculation, the discrepancy value should be ignored, as it will always be very close to zero due to the lack of the opposite coils "counteractions".

5. If the coil is excluded from the calculation by setting its inductance outside the permissible range, its number is displayed in blue. If there are no coils excluded from the calculation, the program performs four additional calculations with successive exclusion of each coil. If the discrepancy is significantly less than the average one, when a certain coil is excluded, this coil number is displayed in red.

5 ACKNOWLEDGEMENTS

The authors express their gratitude to the employee of the Zaporizhzhia branch of the State Enterprise "The State Research Institute of Building Constructions", namely to V. Shokarev, the former director, Ph.D. in Engineering and Senior Scientist, for their valuable instructions and consultations during writing the program and conducting the field studies.

6 REFERENCES

- Marienkov, M., Kaliukh, I., Trofymchuk, O. 2024. The digital twin use for modeling the multi-storey building response to seismic impacts. *Structural Concrete*, vol. 25, issue 3: 2079-2096. doi: <https://doi.org/10.1002/suco.202300695>
- Kaliukh, I., Vasylenko, V., Berchun, Y., Vapnichna, V., Sedin V. and Tytarenko, O. 2023. The Computational Intelligence application for assessing the technical state of a multi-storey building damaged by an explosion. *2023 IEEE 4th KhPI Week on Advanced Technology (KhPIWeek)*, Kharkiv, Ukraine, pp. 1-5. doi: 10.1109/KhPIWeek61412.2023.10312914.
- Zgurovsky, M., Zaychenko, Y. 2019. *Big Data: Conceptual Analysis and Applications*. International Publishing Switzerland: Springer International Publishing.
- Zgurovsky, M., Zaychenko, Y. 2016. *The Fundamentals of Computational Intelligence: System Approach*. Switzerland: Springer International Publishing.

- Pankratova, N., Malishevsky, A., Pankratov, V. 2022. Cyber-Physical Systems Operation with Guaranteed Survivability and Safety Under Conditions of Uncertainty and Multifactor Risks. In: M. Zgurovsky, N. Pankratova, (eds) *System Analysis & Intelligent Computing. SAIC 2020. Studies in Computational Intelligence*, vol 1022. Cham: Springer. doi: https://doi.org/10.1007/978-3-030-94910-5_2
- Kaliukh, I., Syvko, I., Chorna, K., Shokarev, V., Shokarev, I., Shokarev, A. 2020. Assessment of Residual Service Life for the Residential Buildings under Systematical Industrial Explosions. *IEEE 2nd International Conference on System Analysis & Intelligent Computing (SAIC)*, Kyiv, Ukraine, 2020, p. 1-4, doi: [10.1109/SAIC51296.2020.9239172](https://doi.org/10.1109/SAIC51296.2020.9239172).
- Shokarev, V., Syvko, I., Shokarev, E., Shokarev, A., Yakovenko, M. 2021. Railway retaining walls under dynamic loading in the Carpathians foothill. *European Association of Geoscientists & Engineers. Geoinformatics, May 2021, Volume 2021*, p.1 – 6. doi: <https://doi.org/10.3997/2214-4609.20215521004>
- Kaliukh, I., Slyusarenko, Y., Marienkov, M., et al. 2025. Application of Digital Twins and IoT for investigating damage caused to buildings under dynamic influences. In: *Proceedings of the fib Symposium 2025, held in Antibes, France, June 16-18, 2025*. Edited by: Matthieu Briffaut and Jean Michel Torrenti: pp. 3102–3113.
- Kaliukh, I., Dunin, V., Marienkov, M. et al. 2023. Peculiarities of Applying the Risk Theory and Numerical Modeling to Determine the Resource of Buildings in a Zone of Influence of Military Actions. *Cybern Syst Anal*, 59, 2023, pp. 612–623. doi: <https://doi.org/10.1007/s10559-023-00596-w>
- Banakh, V. et al. 2025. Digital Twins and BIM Technologies for the High-Rise Building's Restoration. In: *Mazzolani, F.M., Landolfo, R., Faggiano, B. (eds) Protection of Historical Constructions. PROHITECH 2025. Lecture Notes in Civil Engineering, vol 595. Springer, Heidelberg (2025)*. Cham. doi: https://doi.org/10.1007/978-3-031-87312-6_71
- Kaliukh, I., Klymenkov, O., Berchun, V., et al. 2024. The excessive tilts elimination in the high-rise buildings using an experimental information and analytical system and digital twins. In: *No. 67. ReConStruct - Resilient Concrete Structures - 20th fib Symposium Proceedings - 11-13 November 2024 - Christchurch, New Zealand*: 2326–2336.
- Trofymchuk, O., Kaliukh, I., Dunin, V., Kyrash, S. 2022. Dynamic certification and assessment of the building's life cycle under regular explosive impacts. *System research and information technologies*, 4, pp. 100-118 doi: <https://doi.org/10.20535/SRIT.2308-8893.2022.4.09>
- Slyusarenko, Y. et al. 2025. Best Historical Practice: The Retaining Wall by Military Engineer Daniel de Bosquet on the Landslide-Prone Slopes of the Kyiv-Pechersk Lavra. In: *Mazzolani, F.M., Landolfo, R., Faggiano, B. (eds) Protection of Historical Constructions. PROHITECH 2025. Lecture Notes in Civil Engineering, vol 596. Springer, Cham*. doi: https://doi.org/10.1007/978-3-031-87316-4_26
- DSTU B V.2.6-156:2010. 2011. Buildings and facilities structures. Concrete and reinforced concrete structures of heavy structural concrete, Kyiv, Minregionbud. Available at: https://online.budstandart.com/ua/catalog/doc-page.html?id_doc=26932 [Accessed 15th July 2025].
- DSTU-N B.1.2-18:2016. 2017. Guidelines for inspection of buildings and facilities for identification and evaluation of their technical condition", Kyiv, Minregionbud. Available at: https://online.budstandart.com/ua/catalog/doc-page.html?id_doc=65833 [Accessed 15th July 2025].
- Titarenko, V., Kaliukh, I. 2025. Digital Twins Applying to the Assessment of the Hostynnyi Dvir Historical Monument Destruction. In: *Mazzolani, F.M., Landolfo, R., Faggiano, B. (eds) Protection of Historical Constructions. PROHITECH 2025. Lecture Notes in Civil Engineering, vol 595. Springer, Heidelberg (2025)*. Cham. doi: https://doi.org/10.1007/978-3-031-87312-6_70
- Trofymchuk, O., Dunin, V., Kurash, S. 2022. Dynamic certification and assessment of the buildings life cycle under regular explosive impacts. *System research and information technologies*, 4, pp. 100-118. <https://doi.org/10.20535/SRIT.2308-8893.2022.4.09>
- Kaliukh, Y., Vusatiuk, A. 2019. Factorization in Problems of Control and Dynamics of Lengthy Systems. *Cybern Syst Anal* 55, pp. 274–283. <https://doi.org/10.1007/s10559-019-00132-9>
- Tytarenko, V., Kaliukh, I. 2025. The metro station modification into a multi-storey shopping center using Digital Twins and Internet of Things. In: *Proceedings of the fib Symposium 2025, held in Antibes, France, June 16-18, 2025*. Edited by: Matthieu Briffaut and Jean Michel Torrenti: pp. 3712–3723.
- Kalyukh, Y., Senatorov, V. 2011. The problems of resource evaluation of highly responsible and especially massive RC hydrotechnical structures. *fib Symposium Prague 2011: Concrete Engineering for Excellence and Efficiency, Proceedings*, v. 1, pp. 627–630.
- Farenjuk, G. et al. 2018. Experimental and Theoretical Diagnostics of Defects in Ferroconcrete Piles Based on Reflection of Longitudinal and Transverse Waves. In: *Proceedings of the fib Symposium 2018 "High Tech Concrete: Where Technology and Engineering Meet"*, Edited by: Hordijk, D., & Luković, M. Springer (2018) Cham: pp. 1307-1317. https://doi.org/10.1007/978-3-319-59471-2_151
- Kaliukh, I., Farenjuk, G., Farenjuk, I. 2018. Geotechnical Issues of Landslides in Ukraine: Simulation, Monitoring and Protection. In: *Proceedings of China-Europe Conference on Geotechnical Engineering. Springer Series in Geomechanics and Geoengineering*. Edited by: Wu, W. & Yu, H.S. Springer (2018) Cham: pp. 1466-14469. https://doi.org/10.1007/978-3-319-97115-5_124
- Trofymchuk, O.M., Kaliukh, I.I., Berchun, Y.O. et al. 2025. Hybrid Numerical Method for the Evaluation of the Seismic Protection of Buildings Based on Digital Twins. *J Math Sci* 291, pp. 883–899. <https://doi.org/10.1007/s10958-025-07858-2>