

INTERNATIONAL SOCIETY FOR SOIL MECHANICS AND GEOTECHNICAL ENGINEERING



This paper was downloaded from the Online Library of the International Society for Soil Mechanics and Geotechnical Engineering (ISSMGE). The library is available here:

<https://www.issmge.org/publications/online-library>

This is an open-access database that archives thousands of papers published under the Auspices of the ISSMGE and maintained by the Innovation and Development Committee of ISSMGE.

Applicability of the Geogauge, P-FWD and DCP for compaction control

Étude des conditions d'application du Geogauge, DP et PDL dans le contrôle du compactage

Conde M.C., Lopes M.G.

ISEL, Lisboa, Portugal

Caldeira L., Bilé Serra J.

LNEC, Lisboa, Portugal

ABSTRACT: Soil compaction is a critical issue in the construction of highway, airport and dam embankments and foundations. The current specifications address embankment compaction in terms of dry density and moisture content. However, achieving a certain dry density and moisture content does not guarantee performance adequacy. So, a comprehensive experimental testing program is under development, on compacted layers to investigate the feasibility of developing a stiffness-based specification for embankment soil compaction quality control. The field test program includes 11 test points on the upstream shell and 6 points on the downstream shell on an earth dam during construction. In each point, 3 geogauge, 10 portable falling weight deflectometer (P-FWD) and 4 dynamic cone penetrometer (DCP) tests were performed. This paper aim is to analyze the experimental data and to show the feasibility of employing these devices for earth work evaluation.

RÉSUMÉ : Le compactage des sols est un point critique dans la construction des fondations et remblais d'autoroutes, aéroports et barrages. Le contrôle classique du compactage se fait par la mesure du poids volumique sec et de la teneur en eau. Cependant les mesures de ces paramètres ne garantissent pas une bonne capacité portante des couches compactées. Ainsi, un programme d'essais est en cours pour étudier la faisabilité de remplacer le contrôle du compactage par des paramètres liés à la portance du sol. Le programme d'essais comprend 11 points de mesure sur la recharge amont et 6 points de mesures sur la recharge en aval d'un barrage en terre en cours de construction. À chaque point ont été pris 3 mesures avec le geogauge, 10 mesures avec le déflectomètre portable (DP) et 4 mesures avec le pénétromètre dynamique léger (PDL). L'objectif principal de cet article est d'analyser et de comparer les résultats obtenus par le geogauge, le DP et le PDL et de montrer la faisabilité d'employer ces appareils pour le contrôle in situ du compactage.

KEYWORDS: soil compaction, compaction control, Geogauge, P-FWD and DCP.

1 INTRODUCTION

Soil compaction is essential in the construction of highways, airports, bridges and embankment dams. Usually, compaction is controlled by measuring the dry density and the water content of the compacted soil. These physical properties are compared with reference values so that adequate mechanical and hydraulic properties may be ensured. An alternative approach based on soil stiffness modulus has been emerging, particularly in transportation infrastructures construction. This approach is supported by the concept that the performance requirements (e.g. soil compressibility) may not correspond to the maximum soil dry density at its optimum water content.

This paper focuses on a comprehensive experimental testing program aiming to correlate the data from three devices, i.e. geogauge, portable falling weight deflectometer (P-FWD) and dynamic cone penetrometer (DCP), for stiffness or penetration measurement to dry density and water content of the compacted soil. The latter experimental data was gathered by traditional methods (sand cone density and microwave oven heating tests, respectively).

The ultimate goal of this study is the assessment of the applicability of earth work evaluation and control by stiffness performance data, just described.

2 EXPERIMENTAL WORK

With the objective to evaluate the applicability conditions of geogauge, portable falling weight deflectometer (P-FWD) and dynamic cone penetrometer (DCP) in compaction control of embankment layers, a series of tests was performed on compacted layers of a zoned earth dam during construction at Alentejo in the southern Portugal. A unique soil was used in

both upstream and downstream shells. For this purpose, a total of 11 test points at the upstream shell and 6 test points at the downstream shell were considered.

Soil samples from each test point were collected close to the field test locations and stored for laboratory characterization.

2.1 Laboratory experimental program

Laboratory tests included index tests and Proctor compaction tests, as summarized in Table 1. An example of the grain size distribution and Proctor curve of upstream and downstream material are shown in Figure 1 and Figure 2, respectively.

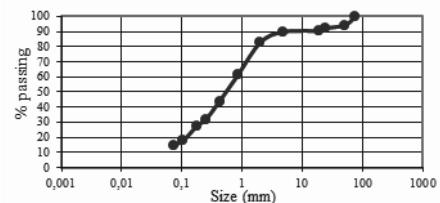

Figure 1. An example of a grain size distribution of shell material.

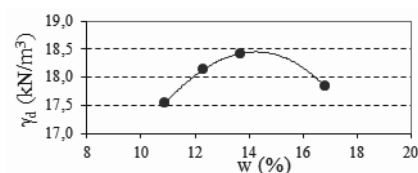

Figure 2. An example of a Proctor curve of shell material.

Table 1. Index properties and compaction tests results.

Location	γ_d^{\max} (kN/m^3)	w_{opt} (%)	w_L (%)	PI (%)	AASHTO Classif.	USCS Classif.
Shell material	18.32	14.5	N/P	N/P	A-1-b (0)	SM

2.2 Experimental layout

In Figure 3 the field tests performed at the different locations within 35 m wide bands, from A to G, are summarized. The layout of the field tests carried out at each position is illustrated in Figure 4. A cross-shaped configuration was selected with the traditional tests at the center and the performance base methods at the cross ends. The sand cone density test was used to measure in-place unit weight, according to ASTM D 1556 standard. Soil samples were also collected from each test position for water content (w) determination in the laboratory by the microwave oven heating procedure, following ASTM D 4643 standard. Measurements with geogauge and P-FWD were taken at surface. The DCP readings were taken continuously along the compaction layer depth, i.e. 40 cm, and recorded every 10 cm.

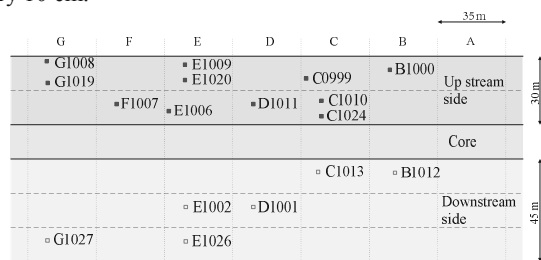

Figure 3. Plan view of the test positions.

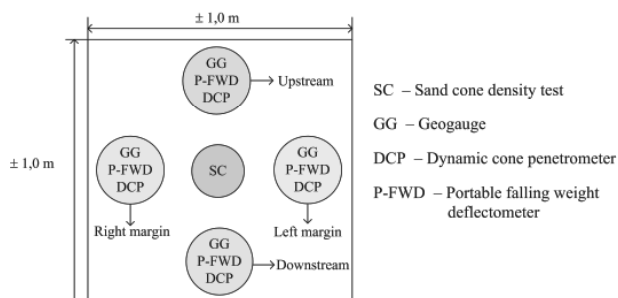

Figure 4. Tests arrangement at each test position.

In order to limit the disturbance caused by each type of test on the results, the following sequence of tests was selected: geogauge, P-FWD and DCP.

2.3 Compaction control

The required properties of the compacted fill layers were established during the construction of a trial embankment. Accordingly, the layers of the shells were compacted to 40 cm thickness by eight passes of a smooth steel drum vibratory roller, model CAT 583. A minimum relative compaction of 95% to the reference standard Proctor was required for compaction approval. Further, regarding maximum water content deviation to optimum water content (owc) up to +2% at the upstream shell and between -2% to +1% at the downstream shell was required.

The soils used in the dam construction came from borrow areas; therefore some degree of heterogeneity in their physical and mechanical properties was anticipated. The compaction control in heterogeneous materials, based on dry density and water content determination at each controlled point would involve a volume of work and delay in the results presentation, with potential interference with the construction schedule. Thus, the Hilf method was selected for control of compaction work (ASTM D 5080). It allows the determination of the relative compaction, RC, and the water content deviation from owc, Δw, based uniquely on the soil density value, thus without water content measurement and previous knowledge of the Proctor reference curve. Table 2 shows the range of results of the compaction control by the Hilf method in upstream and

downstream shells. As summarized in Table 2 the relative compaction and water content deviation values lie within the expected ranges.

Table 2. Range of compaction results control by the Hilf method.

Location	γ (kN/m ³)	$\gamma_{d \max}$ (kN/m ³)	RC (%)	Δw (%)
Upstream	20.2 to 21.3	17.5 to 18.8	98.5 to 99.7	+0.1 to +1.7
Downstream	19.9 to 20.8	17.6 to 18.3	97.6 to 99.7	-0.7 to +0.7

2.4 Geogauge testing

The geogauge device testing procedure is based on the response of a linear elastic medium to a dynamic force applied at the surface. It allows the determination of the elastic Young modulus of the near surface material. The geogauge is a cylinder with a height of 270 mm and a diameter of 280 mm, as shown in Figure 5. The equipment weighs approximately 100 N. The device rests on a circular ring placed and seated firmly at the soil surface. The base cylinder has an outside diameter of 114 mm and an inside diameter of 89 mm. The geogauge shaker scans the frequency domain between 100 and 196 Hz with 4 Hz increments, totaling 25 individual frequencies (Alshibli *et al.*, 2005). During the test sequence, the small amplitude deflection δ and the applied force F are recorded, thus enabling the determination of the soil vertical specific stiffness, the so-called geogauge stiffness (K_{GG}). The average of the 25 stiffness values is taken as the representative value of K_{GG} . The elastic Young's modulus (E_{GG}) of the soil is then computed by the equation:

$$E_{GG} = k_{GG} \frac{1 - \nu^2}{1.77R} \quad (1)$$

where ν is the Poisson's ratio and R is the radius of the geogauge base (57.15 mm), being E_{GG} expressed in MPa and K_{GG} in MN/m.



Figure 5. Geogauge device.

2.5 P-FWD testing

The P-FWD device used was a Prima 100. It consists of four major parts: the sensor body, load plate, buffer system and sliding weight (Figure 6).

The sensor body encloses a load cell and a geophone. The latter is spring mounted at the center of the load plate and measures the deflection of the surface caused by the impact load. The Prima 100 allows the user to vary the drop height, weight, plate diameter and the number of rubber buffers.

The adjustment of the weight and drop height allows one to adjust the impact energy. Additional drop weight increases the stress exerted by the plate. By changing the size of the loading plate diameter the stress imparted onto the sub-grade soil may also be adjusted. The number of rubber buffers can be selected to alter the duration of the load impact impulse.

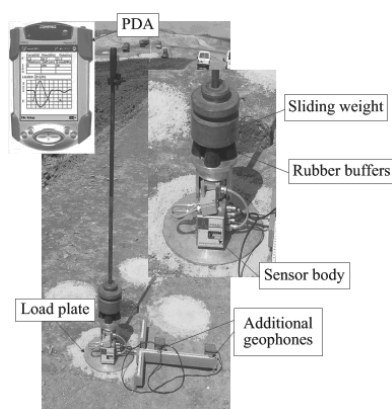

Figure 6. Prima 100 P-FWD device.

The device measures both force and deflection. The software enables the selection of test setup and to visualize and save the test results. Time histories and peak values of load and deflection are displayed in a hand-held computer (PDA). The peak values of load and deflection allow determining the elastic stiffness modulus, E_{P-FWD} . The equation used to determine E_{P-FWD} is based on the Boussinesq's equation. It corresponds to calculating the surface modulus of a layered material under a uniform circular load of radius R , assuming an uniform Poisson's ratio:

$$E_{P-FWD} = \frac{f(1-\nu)^2 \sigma R}{\delta_c} \quad (2)$$

where f is the stress distribution factor, assumed 2.0 (flexible plate), ν is the Poisson's ratio, assumed 0.35, σ is the (peak) impact stress under the loading plate (kPa), R is the P-FWD loading plate radius (150 mm) and δ_c is the (1st peak) P-FWD deflection (μm).

Initially, a 300 mm diameter loading plate, four buffers, a 15 kg falling mass and a 0.8 m drop height were adopted. This configuration proved to be inadequate due to the excessive energy involved which caused the apparatus to detach from the ground after impact. It was observed that this affected the accuracy of the deflection measurement. The experimental setup was then changed to a 10 kg falling mass and a 0.4 m drop height, which proved to be adequate in terms of contact and reading accuracy (Conde *et al.*, 2009). With this setup the equipment applies a contact pressure between 85 and 100 kPa.

2.6 DCP testing

Dynamic cone penetrometer (DCP) allows a simple, fast, and economical usage and provides continuous measurement of the penetration resistance of embankment or pavement layers. The DCP consists of a steel rod with a cone tip at the end. In this study a light weight configuration was used, i.e. with a 10 kg hammer, with a falling height of 50 cm (Figure 7).

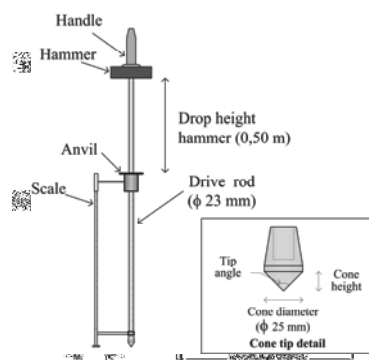

Figure 7. DCP device.

In this study DCP testing was performed according to EN ISO 22476-2 standard. The readings were taken continuously through the compaction layer depth, i.e. along 40 cm, and recorded every 10 cm. Based on the total number of blows required to drive the penetrometer through the layer, the average penetration rate at each 10 cm penetration PN10 (mm/blow) or the cumulative number of blows N_{10} were calculated.

3 RESULTS ANALYSIS

To evaluate the performance of these devices as tools for the compaction control of embankment layer, the sensitivity of the results to variations in water content and in dry density of geomaterials determined by traditional methods was assessed.

3.1 K_{GG} results

Figure 8 shows the correlation between water content (w) and K_{GG} . The chart shows some scattering about the adjusted negative exponential trend which limits the quality of the adjustment. A significant increase of the geogauge stiffness with decreasing water content may be inferred from the data both in the upstream and in the downstream shells.

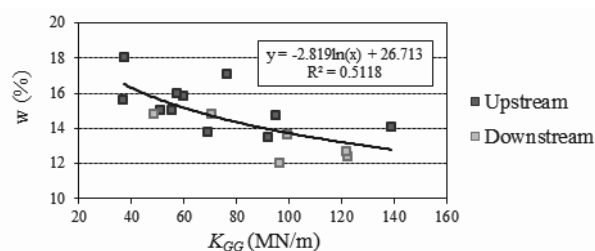
 Figure 8. Relation between soil stiffness, k_{GG} , and water content, w .

Regarding the dependence of K_{GG} on the *in situ* dry density, the results in Table 2 present minor variations of the relative compaction, i.e. of γ_{dSC} , thus making the correlation analysis difficult. Conde *et al.* (2010) analyzed these results concluding that small and erratic sensitivity of stiffness values determined by geogauge occurred with only relatively small variations in dry density (Figure 9).

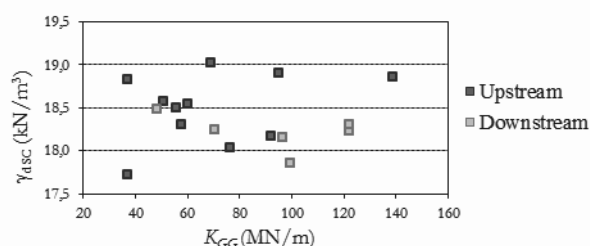
 Figure 9. Soil stiffness, k_{GG} , and dry density, γ_{dSC} , results.

The joint consideration of both results seems to indicate that soil stiffness is only a reliable predictor of the water content variation. This sensitivity of stiffness to changes in water content were also observed by Abu-Farsakh *et al.* (2004) in a study conducted on fine soils (silt, sandy clay and clay).

3.2 E_{P-FWD} results

Figure 10 shows the relationship between the elastic stiffness modulus (E_{P-FWD}) and the *in situ* water content (w). While the adjusted trend is again of the negative exponential type, a smaller scatter is now observed in comparison with that of the geogauge results.

The correlation between P-FWD results and dry density values showed significant scatter. However, the same tendency was verified for E_{P-FWD} , which increases with dry density increase, as happened with the values obtained with the geogauge equipment.

Similarly to the case of the K_{GG} , the variation of E_{P-FWD} with dry density was negligible, thus restraining the conclusions about the sensitivity of the elastic stiffness modulus to water content variation.

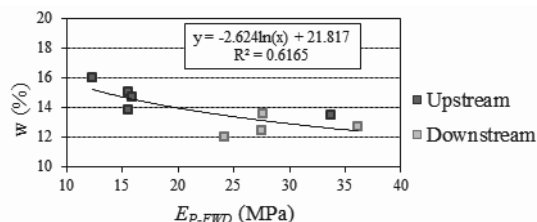

Figure 10. Relation between elastic stiffness modulus, E_{P-FWD} , and water content, w .

3.3 DCP results

DCP tests were carried out with penetration through the layer thickness, i.e. 40 cm. The cumulative number of blows was calculated by adding N_{10} for each 10 cm of penetration successively. Given the reduction of N_{10} in the last 10 cm penetration, lower compaction efficiency at the lower of the layer was identified in some test points. As the vibrating roller with smooth drum transmits energy to the layer from the surface to the base, deficiency in compaction energy is prone to occur at the base of the compaction layer. The decrease in N_{10} between 30 and 40 cm depth occurred mainly in the downstream shell compacted at the dry side of optimum water content.

Whenever a relatively homogeneous condition was identified, equivalent conclusions were obtained based on the cumulative number of blows or on average penetration rate (Conde *et al.* 2012). Otherwise, it was decided to select the most representative depth for data processing. In these cases the best quality correlation between water content and cumulative number of blows were obtained at 30 cm depth, as illustrated at Figure 11. The determination coefficient is here much higher than those obtained with the previous equipments, showing its adequacy for compaction control.

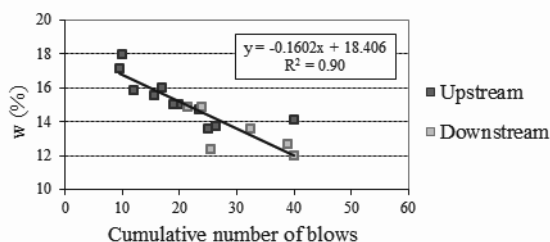

Figure 11. Relationship between cumulative number of blows at 30 cm depth and water content, w .

Alike to the results of the other two equipments, the relationship between DCP cumulative number of blows and dry density had a significant dispersion, and it wasn't possible to establish a correlation. Nevertheless, the downstream shoulder penetration was observed to be higher than that of the upstream one.

4 CONCLUSION

In order to assess the applicability of geogauge, portable falling weight deflectometer and dynamic cone penetrometer devices as compaction control tools, they were used during the

construction of an earth dam in southern Portugal to control the compaction of the upstream and downstream shells. The following conclusions and remarks may be drawn from the current research :

- P-FWD results can be affected by an inadequate configuration choice.
- Stiffness values by geogauge tests and stiffness modulus by P-FWD tests, despite some dispersion, showed an exponential negative correlation with water content. Higher correlation to water content was apparent on downstream shell, i.e. at dry compaction conditions.
- A good quality linear correlation between DCP results and water content was found. As a remark, in the presence of heterogeneous conditions within the compaction layer careful choice of the reference testing depth is needed.
- In all testing points, only a small variation in dry density was observed (RC between 98 and 100%), thus putting this experimental program off as a data base provider for the assessment of the applicability of geogauge, P-FWD and DCP to relative compaction control. Further research is necessary with significant variation of dry density between tests in order to clarify the correlation of the readings to compaction.
- Among the equipments used in this study the DCP equipment showed greater suitability as a compaction control tool, due to the strong negative correlation with water content values.

5 ACKNOWLEDGMENTS

The authors gratefully acknowledge the dam owner EDIA for the permission for testing and the dam contractor MONTE ADRIANO for the in situ assistance. Also thanks are due to LNEC technicians Mr. Joaquim Timóteo da Silva, Mr. Rui Coelho and Mr. António Cardoso.

6 REFERENCES

- Abu-Farsakh, M. Y.; Alshibli, K.; Nazzal, M. and Seyman, E. 2004. *Assessment of In-Situ Test Technology For Construction Control of Base Courses and Embankments*. Technical Report n°FHWA/LA.04/385, Louisiana Transportation Research Center, Baton Rouge, LA. USA. 126p.
- Alshibli, K. A.; Abu-Farsakh, M. and Seyman, E. 2005. Laboratory Evaluation of the Geogauge and Light Falling Weight Deflectometer as Construction Control Tools. *Journal of Materials in Civil Engineering*, 17 (5), 560-569.
- American Society for Testing and Material. ASTM D4643 - 2000. "Standard Test Method for Determination of Water (Moisture) Content of Soil by the Microwave Oven Method", ASTM International, USA.
- American Society for Testing and Material. ASTM D1556 - 2007. "Standard Test Method for Density and Unit Weight of Soil in Place by the Sand-Cone Method", ASTM International, USA.
- American Society for Testing and Material. ASTM D5080 - 2008. "Standard Test Method for Rapid Determination of Percent Compaction", ASTM International, USA.
- Conde, M. C.; Caldeira, L. and Lopes, M. G. 2010. Study of application conditions of the geogauge and the portable falling weight deflectometer in compaction control. in Portuguese *Proceedings of the XII Congresso Nacional de Geotecnia*, Guimarães, Portugal.
- Conde, M. C.; Lopes, M. G. and Caldeira, L. 2009. Stiffness methods for compaction control: the P-FWD device. *Proceedings of the 17th International Conference on Soil Mechanics and Geotechnical Engineering*, Cairo, Egypt.
- Conde, M. C.; Caldeira, L.; Bilé Serra, J. and Lopes, M. G. 2012. Study of dynamic cone penetrometer performance for soil compaction control. in Portuguese *Proceedings of the XIII Congresso Nacional de Geotecnia*, Lisbon, Portugal.
- EN ISO 22476-2. 2005. Geotechnical investigation and testing – Field testing – Part 2: Dynamic probing.