

# INTERNATIONAL SOCIETY FOR SOIL MECHANICS AND GEOTECHNICAL ENGINEERING



*This paper was downloaded from the Online Library of the International Society for Soil Mechanics and Geotechnical Engineering (ISSMGE). The library is available here:*

<https://www.issmge.org/publications/online-library>

*This is an open-access database that archives thousands of papers published under the Auspices of the ISSMGE and maintained by the Innovation and Development Committee of ISSMGE.*

# Pseudo-static Pile Load Test: Experience on Pre-bored and Large Diameter Piles

Tests de chargement pseudo-statique sur pieux: experiences sur pieux forés de grands diametres

Rinaldi V.A.

National University of Cordoba, Argentina.

Viguera R.

Principal Engineer, CIM SRL consultants, Cordoba, Argentina

**ABSTRACT:** Pseudostatic load test is usually employed as an alternative to the conventional static load test for piles. Recent developments showed that the well developed Statnamic tests can be substantially simplified by using a hanging weight falling over a cushion system that allows increasing the time length of the generated stress pulse. This work describes the design of the test method and a recently experience related to the application of the pseudostatic load test used to evaluate the bearing capacity of large diameter piles. The performed test showed that using moderate loads from 10 to 20 tons falling from 10 cm to 120 cm and cushions prepared at varied stiffness allowed to reach more than 800 tons of loading and the fully mobilization of the pile ultimate capacity. The main advantages of the proposed pseudostatic tests respect to the conventional Statnamic tests is the possibility to apply load increments by steps, the repeatability of each loading step and the simpler test setup required by the former.

**RÉSUMÉ :** Des essais de chargement pseudo-statique ont été récemment proposés comme alternative à l'essai de chargement statique classique sur pieux. Les développements expérimentaux récents ont montrés que ces tests peuvent être simplifiés par l'utilisation d'une masse suspendue qui tombe sur un système amortissant. Ainsi cette technique permet d'augmenter le temps de l'application de la charge impulsionnelle. Ce travail décrit la conception de l'expérience et les essais qui ont récemment été effectués pour évaluer la capacité portante de pieux de grand diamètre. Les tests effectués ont montrés que l'utilisation de charges modérées de 10 à 20 tonnes tombant d'une hauteur de 10 à 120 cm sur des amortisseurs à rigidités contrôlés, permettent de simuler plus de 800 tonnes de chargement et d'atteindre la charge ultime du pieu. Les principaux avantages des essais pseudo-statiques sont la possibilité d'appliquer des incréments de charge, une répétabilité de chaque chargement et un essai plus simple à réaliser.

**KEYWORDS:** Pile load test- Statnamic- pseudostatic test- bearing capacity-shaft resistance, tip resistance.

## 1 INTRODUCTION.

The in-situ determination of bearing capacity of the pre-bored piles has historically been performed by means of the conventional static load tests as described in the ASTM C1143-69. The implementation of this type of test on piles of very large ultimate capacity becomes cumbersome resulting fundamentally from the extremely heavy and complex system for the load reaction. The interpretation of the tests is straight forward however it may be affected by the proximity of the piles of reaction. To overcome these difficulties other alternatives such as dynamic load test was proposed. In this test the load is applied by the impact of a falling mass dropped from various heights depending on the desired loading requirements. The maximum height depends on the capacity of the pile. The interpretation of this test is performed by using the wave equation (Smith, 1960) applied to a discrete soil-pile model, from which are determined the static shaft and tip soil resistance and the load-settlement curve of the pile. Conceptually the method is very robust; nevertheless its main limitation is that the applied test loads produce tensile stresses that may cause breakage of the pile shaft.

Pseudoestatic methods become an interesting alternative that significantly overcomes the limitations of the other types of tests. In this group can be mentioned the Statnamic method (see for example Bermingham and Janes, 1989), and the non-conventional tests based on free-falling and accelerated falling mass impinging on a special cushion (eg. Schellingerhout and Revoort, 1996; Matsuzawa et al., 2008; Miyasaka et al 2008).

The fundamental difference with respect to the dynamic tests is the of time of application of the load as shown in Figure 1. In

pseudoestaticos methods, the time of application of the load should be:

$$t_{50} \gg \frac{2l}{V_p} \quad (1)$$

Where  $l$  is the pile length and  $V_p$  is the wave propagation velocity of the pile shaft which for concrete is usually adopted a value of 4100 m/s.

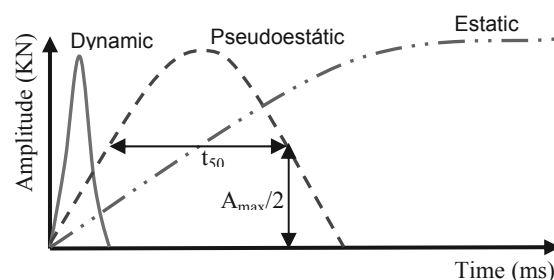

Figure 1. Loading functions of the different loading test for piles.

Usually it is recommended for a pseudo-static condition:

$$\lambda = V_p t_{50} > 7 a 10 l \quad (2)$$

If assumed the loading condition imposed by equation (1) and (2), the interpretation of the soil-pile interaction can be that of the simple physical model described in Figure 2.

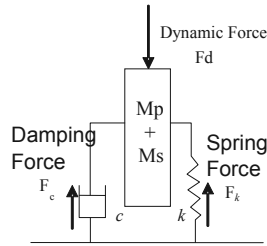

Figure 2: Model for the soil pile interaction in the pseudo-static model.

To increase the application time of loading, a high strength resilient material is required to be placed on the head of the pile in the area of impact. Assuming that the load is obtained by a falling mass of approximately 10% of the ultimate capacity of the pile ( $F_u$ ) and also considering the charging triangular diagram of Figure 3, then:

$$t_{50} = \frac{m\sqrt{2gh}}{F_u} = \frac{0.1F_u\sqrt{2gh}}{F_u} = 0.1\sqrt{\frac{2h}{g}} \quad (3)$$

Where  $h$  is the falling height of the mass  $m$ . This cinematic equilibrium equation is an approximation since restitution forces has been overridden.

The maximum forces that can be exerted on the pile tip ( $F_{max}$ ) due to the falling mass on a cushion material of elastic constant  $k_e$  can be calculated as:

$$m g h = \frac{1}{2} F_{max} z_{max} \quad (4)$$

Where  $z_{max}$  is the maximum deformation of the cushion material  $z_{max} = F_{max}/k_e$ . Then, replacing in equation (4),

$$F_{max} = \sqrt{2 m g h k_e} \quad (5)$$

Being the natural frequency of the mass-cushion system:

$$T = 2\pi\sqrt{\frac{m}{k_e}} \quad (6)$$

Since  $t_{50}$  is half of the natural frequency and assuming a triangular shape of the wave (see Figure 3):

$$\pi\sqrt{\frac{m}{k_e}} > t_{50} > \frac{2}{3}\pi\sqrt{\frac{m}{k_e}} \quad (7)$$

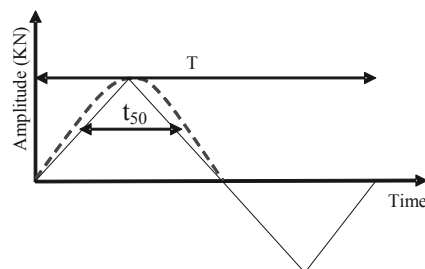

Figure 3: Simplified model of the stress pulse.

Equations (5) to (7) allows to evaluate the magnitude of the mass and the falling height to obtain a maximum force  $F_{max}$  according to the elastic constant  $k_e$  of the cushion material.

From Figure 2, the equilibrium equation can be derived as:

$$F_d - F_c - F_k = (M_s + M_p)a \quad (8)$$

Where  $M_s$  and  $M_p$  are the mass of the pile and the soil respectively and  $a$  is the acceleration of the movement. Equation (8) can be rewritten in terms the resistant forces as a function of the dynamic parameter  $F_c = c v$ , and  $F_k = k u$ , being  $u$  and  $v$  the displacement and velocity of displacement respectively:

$$F_d - c v - k u = (M_s + M_p)a \quad (9)$$

Equation (9) allows determine dynamic influence on the measured force at the point of where the velocity becomes zero and thereafter correcting the measured force by the dynamic effect.

## 2 TESTING PROCEDURE.

Figure 4 and 5 sketch the testing setup and electronic devices used for the pseudo-static load test. This loading design generates a time-controlled load which will depend on the magnitude and height of the falling mass, and geometry and elastic properties of the elastomeric cushion included between the mass and head of the pile. The force pulse is captured by a load cell placed below the cushion. The displacement of the pile is obtained from the double integration of the signals captured by two accelerometers placed on the shaft and below one diameter from top of the pile. The weight of the mass to be used ranges between 5% and 10% of the serviceability capacity of the pile. The test requires the continuous increment of the height of drop of the mass. The output of the conditioners is then digitized by the dynamic analyzer and conveniently stored for subsequent laboratory analysis. In addition to the equipment shown, a proximeter is placed to capture displacements and permanent settlement of the pile. The maximum testing load is obtained when a permanent displacement is generated or until the 50% of the service load is reached.

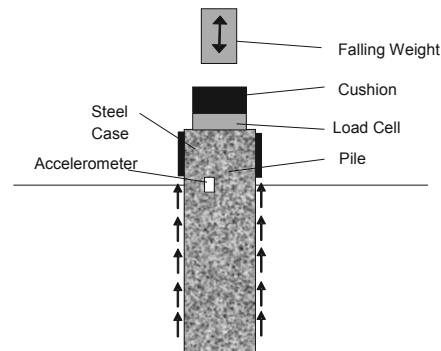

Figure 4: Testing setup for the pseudo-static load test.

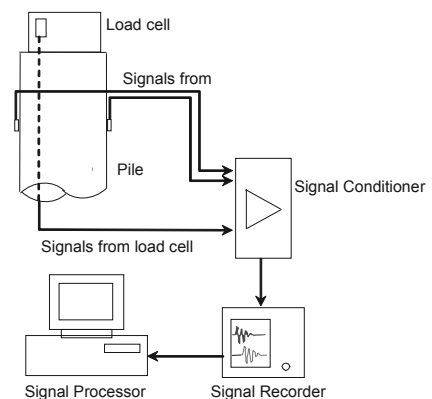

Figure 5: Testing electronic devices used for the pseudo-static load test.

The impact mass can be made at the site usually employing a concrete slab or a steel casing filled with concrete depending on its size. For the purpose of centering the load, steel bars are used as guides for obvious safety reasons and ensuring the impact of the mass be centered avoiding the generation of moments. For the purpose of preventing the damage of the pile by the application of impact on the mass, the shaft is increased (1.5 to 2 times the diameter) by means of a steel case of the same diameter of the shaft. In all cases, the accelerometers must be positioned below this extension or in a window made on it. The

load cell is cylindrical and of stainless steel of the same diameter as the damper.

### 3 CASE HISTORY.

This work describes the results of two pseudostatic load tests performed on large diameter piles built for a bridge over the River Calchaquí on the state highway No 37, in the province of Santa Fe, Argentina. For this bridge were projected sixteen piles of 1.20 m in diameter and approximately 24 m long with preload cell. The soil profile of the site is characterized by the presence of reddish-colored silty clays with interbedded more greenish layers. The compactness of the soil has significant horizontally and vertically variations. At the foundation depth of 24 m the penetration resistance is higher than 50 blows of the normalized Standard Penetration Test. Ultrasonic cross hole tests (ASTM D6760) were performed in all the piles on the six prospecting pipes before and after the load test. The service load of each pile was designed for 4800 kN and the falling mass was 25 tn. The mass was hanged and dropped using a free fall crane (see Figure 6).



Figure 6. Picture of one of the piles tested at the site.

Figures 8 to 10 show the typical curves of the recorded force, velocity and displacement for a single drop of the mass. Note that loading times exceed the 50 milliseconds which for the present case can be considered pseudostatic.

Figures 9 and 10 show the curves of load-settlement obtained for the two piles tested in this work. Notice that in these figures the results from all mass drops have been included. The envelope correspond to the total envelop and the corrected envelop to account for dynamic effect using equation (9) at the point where the velocity is zero or where the maximum displacement is attained.

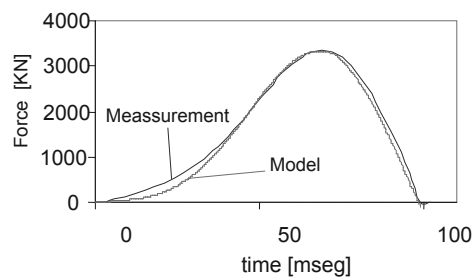

Figure 7. Force function for a falling weight of 25 tn from a drop height of  $h=2.2$  m

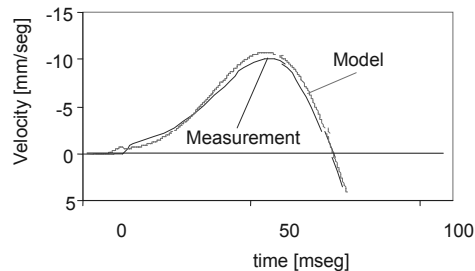

Figure 8. Velocity function for a falling weight of 25 tn from a drop height of  $h=2.2$  m

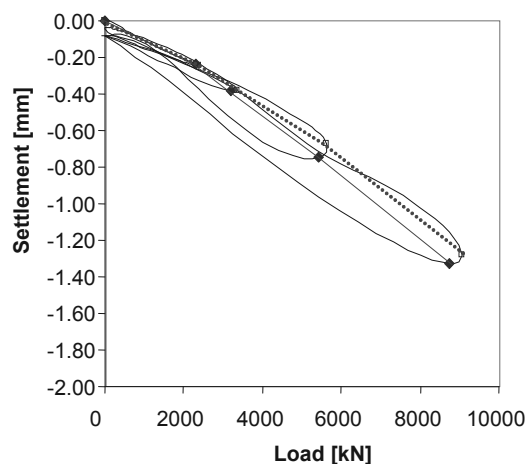

Figure 9. Load- settlement envelopes for the pile P2-S tested in this work. Dotted line corresponds to the total envelop and filled line to the corrected envelop by removing the dynamic effect.

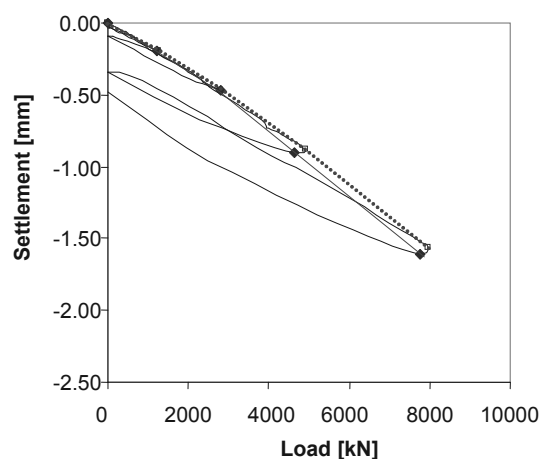

Figure 10. Load- settlement envelopes for the pile P3-S tested in this work. Dotted line corresponds to the total envelop and filled line to the corrected envelop by removing the dynamic effect.

Notice that the maximum loads were around 8000 kN and settlements were in between 1.4 mm and 1.50 mm for the maximum load imposed. At the service load is expected a settlement lower than 0.6 mm.

The piles were also modeled by using the wave equation model formulated by Smith (1960). The pile shaft was divided in sections of one meter and the soil was modeled as spring and dashpots. The dynamic constants were varied until the best approximate of the model to the measurements were obtained. Figures 7 and 8 show the agreement of the modeled pile to the measurements. The distribution of reaction forces along the pile shaft is shown in Figure 11. It seems that most of the load is taken by the shaft an only 900 kN are taken by the tip at the maximum load of the test performed. The behavior of pile-soil systems corresponds to a quasi elastic phase with little plastic deformations.

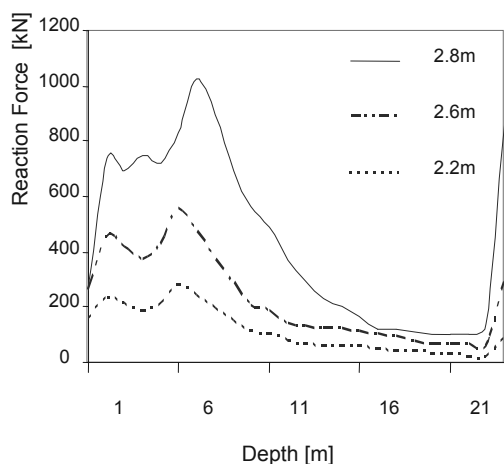

Figure11. Distribution of reaction forces along the pile shaft obtained from the solution of the wave equation for different drop height of the mass.

#### 4 CONCLUSIONS

The conclusions of the work presented here can be summarized as follow:

- a) The pseudostatic test can be performed for most piles using a proper design of the cushion system and falling weight.
- b) The falling weight method is advantageous respect to most other pile loading test since it can be performed much easier, at lower costs and at higher productivity per day.
- c) The pseudostatic test procedure has also the advantage that can be interpreted as the conventional static test and also using the Smith's wave equation.
- d) There is a need to compare the results from pseudostatic tests and static tests, however, since the pseudostatic test is physically identical to the Statnamic method, the well established comparison between Statnamic and static can be extended to the pseudostatic falling weight test.

#### 5 REFERENCES

Bermingham P. and Janes M., 1989. Innovative Approach to Load Testing of High Capacity Piles, Proc. Int. Conference on Piling and Deep Foundations, London, pp. 409-413.

Goble G. and Likins G., 1996. On the Application of PDA Dynamic Pile Testing, Proc. 5th Intern. Conf. on the Application of Stress Wave Theory to Piles, Orlando, FL.

Matsuzawa K., Nakashima Y. and Matsumoto T., 2008. Spring Hammer Rapid Load Tests Method and Its Validation, Proc. of the 2nd BGA International Conference on Foundations, Brennan A. And Knappedt J. Ed., pp.224-234.

Miyasaka T., Kuwabara F., Likins G. and Rauche F., 2008. Rapid Load Test on High Bearing Capacity Piles”, Science Technology and Practice, Dos Santos J. Ed., pp. 5001-5006.

Schellingerhout A.J.G. and Revoort E., 1996. Pseudostatic Static Pile Load Tester, Proc. Of 5th international Conference of Stress Wave Theory to Piles, Orlando, pp.1031-1037.

Smith, E. A. L. 1960. Pile Driving Analysis by the Wave Equation, Journal of the Soil Mechanics and Foundations Division , ASCE, Vol. 86, No. SM4, Proc. Paper 2574, pp. 35-61, Agosto, 1960