

INTERNATIONAL SOCIETY FOR SOIL MECHANICS AND GEOTECHNICAL ENGINEERING



This paper was downloaded from the Online Library of the International Society for Soil Mechanics and Geotechnical Engineering (ISSMGE). The library is available here:

<https://www.issmge.org/publications/online-library>

This is an open-access database that archives thousands of papers published under the Auspices of the ISSMGE and maintained by the Innovation and Development Committee of ISSMGE.

Load Tests on Full-Scale Bored Pile Groups

Essais de chargement sur des groupes de pieux forés

Zhang Y., Salgado R.
Purdue University, USA

Dai G., Gong W.
Southeast University, China

ABSTRACT: Pile groups are commonly used in foundation engineering. Due to the difficulties and cost of full-scale load tests, most pile group tests are scaled down regardless of whether performed in the field or laboratory. Very limited experimental data are available on the loading of full-scale bored pile groups in the field. This paper reports the results of axial static load tests of both full-scale instrumented pile groups and single piles. Experiments vary in the number of piles in the group, the pile spacing, the type of pile groups and pile length. All piles have a diameter of 400 mm. Two-pile groups, four-pile groups and nine-pile groups with pile lengths of 20 m and 24 m are tested. Since the isolated piles and some piles in the pile groups are instrumented, the load transfer curve and the load-settlement curve of both of piles in isolation and individual instrumented piles in the groups are obtained. The interaction coefficient for each pile in the group is back-calculated from the measured data by optimization. The interaction coefficients are shown to depend on pile proximity, as usually assumed in elastic analyses, but also on settlement and on the size of the group.

RÉSUMÉ : Les groupes de pieux sont couramment utilisés dans les travaux de fondation. En raison des difficultés et du coût des essais de chargement à grande échelle, la plupart des essais de groupe de pieux sont réalisés à petite échelle indépendamment de la réalisation des essais en laboratoire ou in-situ. Très peu de données expérimentales sont disponibles sur le chargement en pleine échelle groupes des pieux forés in-situ. Cet article présente les résultats d'essais de chargement statique axial à grande échelle des groupes de pieux et des pieux simples instrumentés. Les expériences varient en nombre de pieux dans le groupe, l'espacement des pieux, le type de groupes et de longueur des pieux. Tous les pieux ont un diamètre de 400 mm. Des groupes composés de deux, quatre ou neuf pieux, avec des longueurs de 20 m et 24 m sont testés. Comme les pieux isolés et quelques uns des pieux dans les groupes sont instrumentés, la courbe de transfert de charge et la courbe de charge-tassement des pieux isolés et en groupe sont obtenus. Le coefficient d'interaction pour chaque pieu dans le groupe est évalué par calcul inverse à partir des données mesurées par l'optimisation. Il a été montré que les coefficients d'interaction dépendent de la proximité des pieux, comme habituellement supposé dans des analyses élastiques, mais également du tassement et de la taille du groupe.

KEYWORDS: pile groups, load transfer, interaction coefficient

1 INTRODUCTION

Settlement analyses of pile groups (e.g., Poulos 1968; Randolph and Wroth 1978, 1979; Poulos and Randolph 1983; Poulos 1989; Randolph 2003; Leung et al. 2010) are based on a variety of approaches, which include boundary-element methods, the hybrid load transfer approach, and the finite element method. Despite some theoretical advances in the analyses and prediction of pile group behavior in the last few decades, analyses are still largely based on simplifications of the problem and of the constitutive behavior of the soil. Due to the difficulties and cost of full-scale load tests, most pile group tests were scaled down regardless of whether performed in the field or laboratory. There are few *in situ*, full-scale bored pile group load tests reported in the literature.

The present paper aims to start filling this knowledge gap by reporting the results of *in situ*, full-scale bored pile group tests. The aim of the tests was to investigate the following crucial issues in particular: (i) what the rates of pile head and pile base load mobilization with settlement are; (ii) how the shaft resistance, which is responsible for the difference between these two rates, varies between single piles and piles in a group in various arrangements; (iii) the proportion in which load applied on a pile cap is shared between the piles in the group; (iv) how pile group efficiency varies with settlement.

2 EXPERIMENTAL PROGRAM

The field load tests on bored piles were performed on: (i) an isolated single pile with length $L = 20$ m; (ii) an isolated single pile with $L = 24$ m; (iii) a two-pile group with spacing $s_p = 2.5B$ (B , the pile diameter) and $L = 20$ m; (iv) a two-pile group with $s_p = 3.0B$ and $L = 24$ m; (v) a four-pile group with $s_p = 2.5B$ and $L = 20$ m; (vi) a four-pile group with $s_p = 3.0B$ and $L = 24$ m; (vii) a nine-pile group with $s_p = 2.5B$ and $L = 20$ m; and (viii) a nine-pile group with $s_p = 3.0B$ and $L = 24$ m. All piles in the experiments had a diameter B of 400 mm. The concrete strength (f'_{cd}) was 25 MPa for both the piles and the caps. The concrete reinforcement cover was 70 mm in the caps and 35 mm in the piles. In this paper, tests on isolated single piles are denoted by DZ. Pile group tests are denoted by QZ. The suffix L is used to indicate that the pile length L is 24 m. A dash after the pile group reference followed by a number indicates a specific pile within that group.

One auger boring was drilled at the test site to a depth of 29.50 m. This boring showed a uniform, thick soft clay layer starting at 17m and extending all the way to the bottom of that boring. This auger boring depth was 11B deeper than the test pile base for piles with 24 m length. Static cone penetration tests (CPTs) were performed in the vicinity of the boring to give a continuous record of the soil resistance with depth. The subsoil profile includes multiple layers of silt and clay. The ground water level was found at a depth of 2.60 m. The detailed soil

properties for each layer at this test site are given by Dai et al (2012).

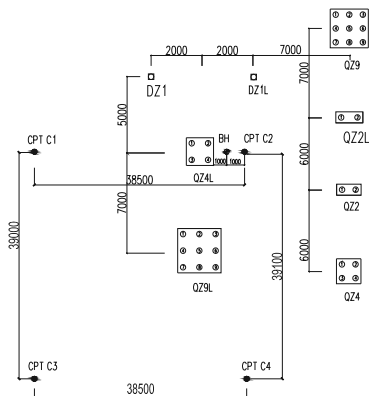

Figure 1. Layout plan of test piles and pile groups (all dimensions in millimeters).

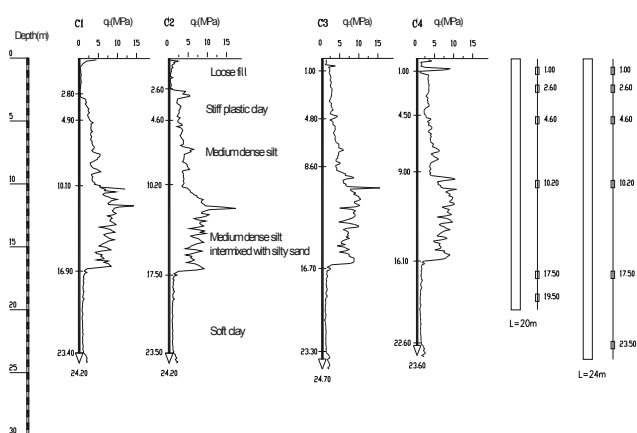

Figure 2. The CPT site logs and the layout of strain gauges in the test piles (all dimensions in meters).

The piles were installed using the slurry method. A 0.4-m-, 0.8-m- or 1.2-m-thick reinforced concrete cap was subsequently poured on the pile groups and single piles. Figure 1 shows a layout plan of the test piles and pile groups. The pile caps rested on the ground and may be considered rigid for practical purposes. The pile spacing was 2.5B in groups QZ2, QZ4 and QZ9 and 3.0B in groups QZ2L, QZ4L and QZ9L.

The axial loads transferred along the instrumented piles were measured by strain gauges, which were installed evenly at each cross section for all test piles. There were 6 instrumented sections in each instrumented pile (Figure 2). A vibrating-wire load cell measured the pile top load of each pile in the pile groups during the loading process. The load tests were performed by the kentledge load method. The load tests were slowly maintained load tests. There were no unload-reload loops. Load was applied by hydraulic jacks. Settlements were measured at four locations on the upper surface of the cap by four displacement transducers.

3 ANALYSIS OF LOAD TEST RESULTS

The load-settlement curves for the two single piles (Figure 3) show that these two curves are almost identical for $Q \leq 900$ kN, corresponding roughly to $0.6Q_{ult}$, with ultimate bearing capacity, Q_{ult} , defined based on the traditional 10% relative settlement criterion (Salgado 2008). For $Q > 900$ kN, the settlement at the pile top is greater for DZ1 than for DZ1L at the same load. The ultimate bearing capacity Q_{ult} is 1430 kN for DZ1 and 1540 kN for DZ1L according to the 10% criterion.

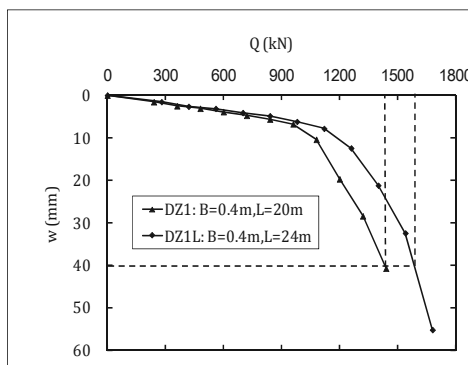

Figure 3. Load settlement curves for single pile tests.

Figure 4 and Figure 5 show the axial load transfer curves for DZ1 and DZ1L throughout the loading process. There is significant transfer of load from the pile to the soil between 2.6 m and 17.5 m for both DZ1 and DZ1L, which makes the resistance at the pile base for both DZ1 and DZ1L comparatively small. At the end of the test, the pile head load for DZ1 is 1440 kN while the pile base load is 31 kN. For DZ1L, the corresponding numbers are 1540 kN and 62 kN. These results suggest minimal and potentially zero base mobilization, which means that essentially all of the loads applied at the pile head are carried by shaft resistance. So both pile DZ1 ($L/B = 50$) and pile DZ1L ($L/B = 60$) derive their resistance from shaft resistance at values of relative settlement conventionally associated with the ultimate load. Complete shaft resistance mobilization in friction piles crossing soft soil layers may require large pile head settlement because of large axial pile compressibility.

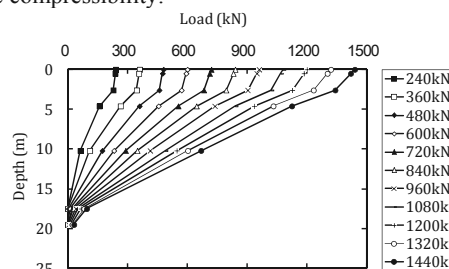

Figure 4. Axial force distribution for 20m-long single pile.

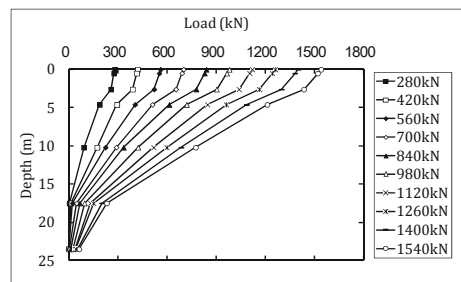

Figure 5. Axial force distribution for 24m-long single pile.

Figure 6(a) shows the load-settlement curves for the single pile and the average load-settlement curves for the pile groups with $L = 20$ m. The average load per pile in a group is less than the load on a single pile at the same settlement except for pile group QZ2. This exception is likely caused by variability in the soil properties around that group or some variability in construction. The equivalent figure for $L = 24$ m is Figure 6 (b), which shows a much more clear separation between the responses of the single pile and the average response of each pile group.

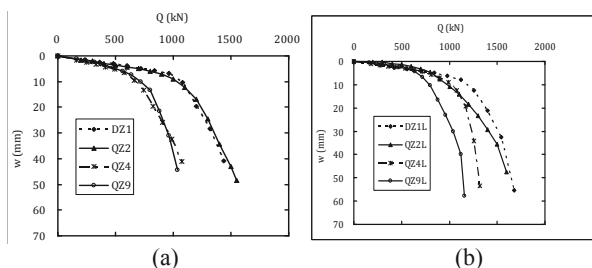

Figure 6. Load-settlement curves for the single pile and the average load-settlement curves for the pile groups: (a) $L = 20$ m; (b) $L = 24$ m.

Figure 7 (a) and (b) show group settlement ratio R_s , the ratio of the settlement of a pile group to that of single pile at the same average load per pile (Poulos and Davis 1980). The values of R_s of both four-pile group and nine-pile group tend to increase with settlement. The single pile settlement is generally smaller than the corresponding pile group settlement at the same average load per pile when the load is relatively large. The R_s values for the two-pile groups are however close to unity. The initial values of R_s (at small loads) are also close to unity, indicating little interaction between the piles.

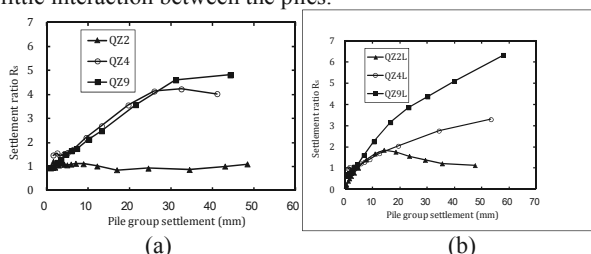

Figure 7. Settlement ratio R_s versus pile group settlement for all pile groups: (a) with $L = 20$ m; (b) with $L = 24$ m.

Figure 8 shows the distributions of unit shaft resistance both for the single pile DZ1L and for some instrumented piles in groups QZ2L, QZ4L and QZ9L at intermediate load steps during the load tests.

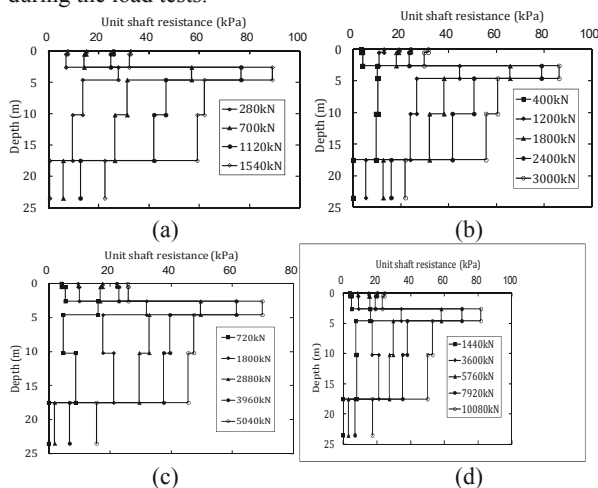

Figure 8 Distribution of unit shaft resistance for the single piles and for the instrumented piles in the pile groups: (a) DZ1L; (b) QZ2L-1; (c) QZ4L-1; (d) QZ9L-1.

The limit shaft resistances were calculated by using the pile design methods proposed by Salgado et al. (2011), which capture the dependence of the unit shaft resistance on the clay undrained shear strength, the normal effective stress on the pile shaft and the difference between the critical-state friction angle and the minimum residual friction angle. Figure 8 shows that the unit shaft resistance is close to a limit value at shallower locations, but that is not the case for deeper locations along the pile. In practical terms, this means that the end of the load tests on the single piles corresponds to state at which the shaft

resistance mobilized along the entire pile is less than the limit shaft resistance.

The pile head and base loads versus pile group load are shown in Figure 9 for piles of the 9-pile groups under different load levels. The corner piles have the largest pile load, followed by side and then central piles. This confirms intuition based on elasticity solutions that if the pile cap is flexible and the loads on every pile are as a result the same, the center pile with lowest stiffness would be expected to settle the most, showing that it has the lowest stiffness. When imposing the same settlement on all piles, we would therefore expect the center pile to carry the smallest load, as indeed observed. The experimental results seem to capture an aspect of pile group response that is not often commented on. The base of the pile located towards the center of the group is more constrained because of the surrounding piles, which may lead to a greater base resistance.

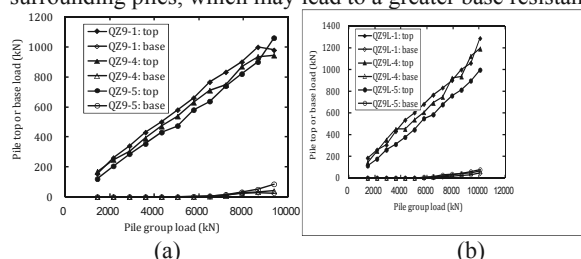

Figure 9 Pile head and base loads versus pile group load for the nine pile groups: (a) $L = 20$ m; (b) $L = 24$ m

Because of symmetry, the head and base loads for piles in two-pile and square four-pile groups are expected to be the same. However, that is not the case for the piles in the nine-pile groups. The ratio Q_i/Q_{av} of the individual pile load to the average individual load in the group is shown in Figure 10. The load on the outer piles of each group is observed to be greater than the average load Q_{av} .

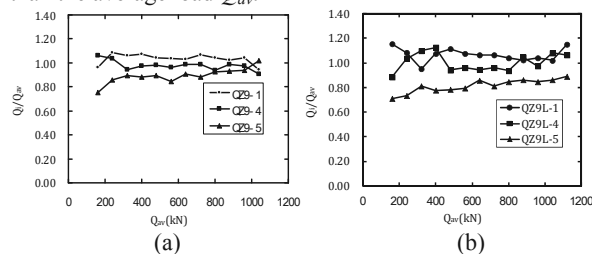

Figure 10 The ratio Q_i/Q_{av} of the individual pile load to the average individual load in nine pile groups: (a) $L = 20$ m; (b) $L = 24$ m.

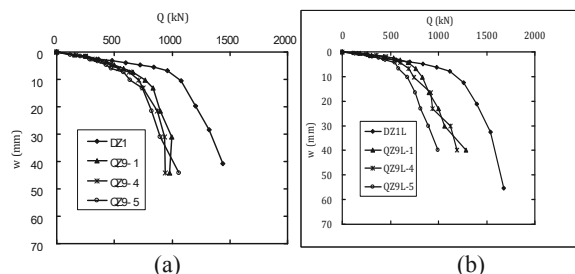

Figure 11 Individual pile load versus group settlement relationship for the two nine pile groups: (a) $L = 20$ m; (b) $L = 24$ m.

Figure 11 shows individual pile load versus group settlement curves for QZ9 and QZ9L. For comparison, the load-settlement curves of DZ1 and DZ1L are also shown in Figure 11. For small group loads, for which linear elastic solutions would be most applicable, a random load distribution is obtained, with no definite pattern. When $Q_{10\%}$ is approached, there is a redistribution of the load, and position of the pile within the group begins to influence the load it carries. Generally, at the same settlement, the load on an individual pile within the group is always less than the load for the corresponding single pile.

4 IMPLIED INTERACTION COEFFICIENTS

This interaction between piles is expressed through the concept of the coefficient of interaction α_{ij} , which is equal to the ratio of the settlement of pile i to the settlement of pile j when pile j is loaded. Using this concept, the settlement of any pile i in a group with a rigid cap is expressed through (Salgado 2008)

$$w_i = \sum_{j=1}^n \alpha_{ij} \frac{Q_j}{K_{tj}} \quad (1)$$

where w_i is the settlement of pile i , α_{ij} is the influence factor between i and j . Q_j is the load acting on pile j , and K_{tj} is the stiffness of pile j (in the sense of how much load is required to have unit pile head stiffness). Details on how to obtain the interaction coefficients using these equations by linear optimization can be found in Dai et al. (2012).

The influence coefficients versus pile group settlements are shown in Figure 12. In general, with the increase of group settlement, the interaction coefficient increases, with an inflection point for small settlements (marking the transition from little interaction for small settlements to a higher level of interaction) and later a tendency of stabilization at large settlements, which is consistent with more intense localization of shear strain around the piles at large settlements, which leads to a reduction in the interaction for incremental settlement.

The results for the 2-pile groups QZ2 are inconsistent with the other results, with the interaction coefficient being practically zero. This may be because of spatial variability of the soil or other variability in the pile installation or pile cap. For the four-pile groups, the pile spacing has a larger effect on interaction than pile length, which is to be expected. The interaction coefficient in group QZ4 with $s_p = 2.5B$ and $L = 20$ m is on average larger than that of group QZ4L with $s_p = 3.0B$ and $L = 24$ m. For the nine-pile group, the interaction coefficients are distributed proportionally to pile center-to-center spacing. The interaction coefficients for the piles in the four-pile group are larger than comparable coefficients (at the same spacing) for the nine-pile group. The presence of additional piles around interacting piles likely interferes with load or settlement transmission between the interacting piles.

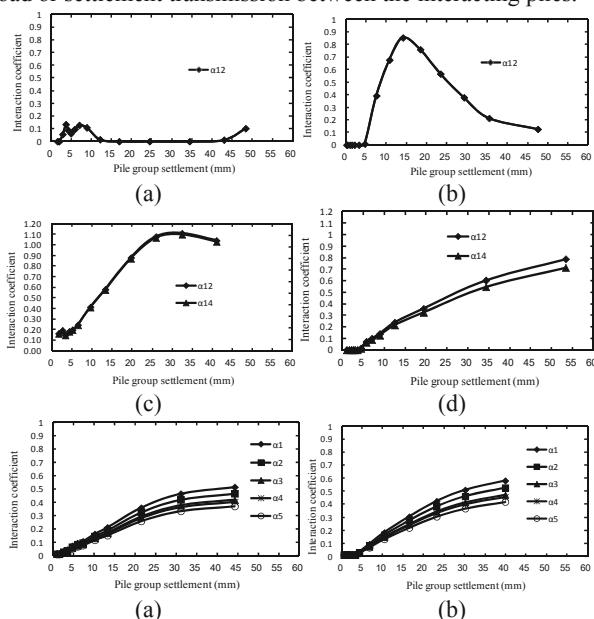

Figure 12. Interaction coefficients versus settlement in each pile group: (a) QZ2; (b) QZ2L; (c) QZ4; (d) QZ4L; (e) QZ9; (f) QZ9L.

5 CONCLUSION

A field pile load testing program was carried out on isolated bored piles and bored pile groups (with two, four, and nine piles

with different pile lengths and pile spacing) installed in a soil profile with mixed layers of clay and silt. Based on the analysis of the field test results, the following conclusions can be reached:

- (1) Based on the traditional $0.1B$ relative settlement criterion, the two single piles DZ1 ($L/B = 50$) and DZ1L ($L/B = 60$) mobilized essentially only shaft resistance, with loads measured at the strain gauge level closest to the pile base accounting for only 2.2% of the total load for the 20-m-long pile and 4% of the total load for the 24-m-long pile.
- (2) The general response of an individual pile in the 2-pile groups was observed to be very close to that of the corresponding single pile, suggesting minimal interaction between piles in the two-pile groups.
- (3) The values of settlement ratio of both the four-pile and nine-pile groups tended to increase with settlement. The single pile settlement was observed to be generally smaller than the corresponding pile group settlement at the same average load per pile when the load was relatively large.
- (4) Group effect was more pronounced for QZ4 than for QZ4L and for QZ9 than for QZ9L, showing that the impact of the pile spacing is greater than that of the pile length on group load response.
- (5) The load at the top of the corner piles was observed to be the largest, followed by side piles and then center piles. However, the load differences were not large, particularly for side versus corner piles.
- (6) The interaction coefficient was seen to be a function of settlement and the size of the group. With the increase of group settlement, the interaction coefficient was observed to increase.

6 ACKNOWLEDGEMENTS

The research was supported by the National Natural Science Foundation of China (Grant No.50908048) and a project funded by the Priority Academic Program Development of Jiangsu Higher Education Institutions (PAPD).

7 REFERENCES

Dai, G., Salgado, R., Gong, W., and Zhang, Y. 2012. Loads tests on full-scale bored pile groups. *Canadian Geotechnical Journal*, accepted.

Leung, Y. F., Soga, K., Lehane, B.M. et al. 2010. Role of linear elasticity in pile group analysis and load test interpretation. *J. Geotech. Geoenviron. Eng.*, 136 (12), 1686 - 1694.

Poulos, H. G. 1968. Analysis of the settlement of pile groups. *Geotechnique*, 18 (4), 449 - 471.

Poulos, H. G., and Randolph M. F. 1983. Pile group analysis: a study of two methods. *J. Geotech. Eng.*, 109 (3), 355 - 371.

Poulos, H. G., and Davis, E. H. 1980. *Pile foundation analysis and design*, Wiley, New York.

Poulos, H. G. 1989. Pile behave - theory and application. *Geotechnique*, 39 (3), 365 - 415.

Randolph, M. F. 2003. Science and empiricism in pile foundation design. *Geotechnique*, 53 (10), 847 - 875.

Randolph, M. F. and Wroth, C.P. 1978. Analysis of vertical deformation of vertically loaded piles. *J. Geotech. Eng.*, 104 (12), 1465 - 1488.

Randolph, M. F. and Wroth, C.P. 1979. An analysis of the vertical deformation of pile groups. *Geotechnique*, 29 (4), 423 - 439.

Salgado, R., Prezzi, M., Tehrani F. S. 2011. "Soil Property-Based Methods for Design of Nondisplacement Piles." 2011 Pan-Am CGS Geotechnical Conference.

Salgado, R. 2008. *The Engineering of Foundations*. McGraw-Hill.