

INTERNATIONAL SOCIETY FOR SOIL MECHANICS AND GEOTECHNICAL ENGINEERING



This paper was downloaded from the Online Library of the International Society for Soil Mechanics and Geotechnical Engineering (ISSMGE). The library is available here:

<https://www.issmge.org/publications/online-library>

This is an open-access database that archives thousands of papers published under the Auspices of the ISSMGE and maintained by the Innovation and Development Committee of ISSMGE.

Model tests for bearing capacity in a lateritic soil and implications for the use of the dynamic cone penetrometer

Tests modèles pour capacité portante sur un sol latéritique et implications dans l'usage du pénétromètre du cône dynamique

Samuel I.K. Ampadu

Kwame Nkrumah University of Science and Technology, Kumasi-Ghana

D. Dzitse-Awuku

Newmont Ghana Gold Limited, Ahafo-Ghana

ABSTRACT

For simple structures in developing countries, the standard methods of site investigation are considered uneconomical. The dynamic cone penetrometer (DCP) has the potential of becoming a simple, rapid, reliable and inexpensive tool that can be used for determining the bearing capacity for foundation design. This study seeks to contribute towards the search for a reasonable correlation by measuring the bearing capacity of a model ground for shallow foundation in the laboratory and correlating it to the DCP test results. A model footing with a rough base was loaded on the surface of a bed of compacted lateritic soil in a Perspex box. The bearing capacity was determined from the stress-penetration curve for different densities ranging from 1.3 Mg/m³ to 1.8Mg/m³. The DCP test was then performed in the mould to obtain the resistance to penetration. Samples were also obtained from the mould and subjected to undrained triaxial compressive test to obtain the strength properties, c and ϕ . The bearing capacity values obtained from the model tests were correlated with the corresponding cone penetration index values for different densities. The relationships obtained are then compared with the bearing capacity computed using Terzaghi bearing capacity equation. The results are discussed with other correlations available in the literature

RÉSUMÉ

Pour des structures simples dans les pays en voie de développement, les méthodes standards d'études in-situ sont considérées peu économiques. Le pénétromètre du cône dynamique (DCP) a la capacité de devenir un outil qui peut être utilisé pour ce but. Cependant, son utilisation est freinée par le manque de corrélation fiable entre la pression portante admissible et les mesures relevées avec le pénétromètre du cône dynamique. Cette étude contribue à trouver une corrélation raisonnable en mesurant la capacité portante d'un modèle de terre pour fondation peu profonde dans le laboratoire et en la mettant en corrélation avec les résultats de mesure du DCP. La capacité portante a été déterminée à travers la courbe charge - pénétration pour densités différentes allant de 1.3 Mg/m³ à 1.8Mg/m³. Le test DCP a été fait dans le moule pour obtenir la résistance à la pénétration. Des échantillons ont été aussi obtenus du moule et soumis à un test de compression triaxial afin d'obtenir les propriétés résistives c et ϕ . Les valeurs de la capacité portante obtenues des tests ont été mises en corrélation avec les valeurs correspondantes de l'index de pénétration du cône pour des densités différentes. Les relations obtenues ont été alors comparées avec la capacité portante calculée à l'aide de l'équation de Terzaghi. Les résultats sont analysés avec les autres corrélations disponibles dans la littérature

Keywords : Model footing, bearing capacity, dynamic cone penetrometer,

1 INTRODUCTION

The allowable bearing pressure is one of the basic parameters required for the design of foundations for civil engineering structures. This parameter is normally calculated from the Terzaghi bearing capacity equation. The conventional method of estimating the parameters required in the equation involves determination of the shear strength parameters through triaxial testing for the case of cohesive soils and in-situ tests such as the Standard Penetration Test for the N-values in the case of cohesionless formations. In many developing countries, these methods are uneconomical and time consuming especially for small scale projects such as development of residential buildings. However, increasingly the submission of a geotechnical report is becoming a requirement for the acquisition of permits for development projects. Therefore there is the need for a simple and economical method for the determination of the bearing capacity as part of site investigation.

The dynamic cone penetrometer (DCP) is a versatile equipment that has traditionally been used in estimating the in-situ California Bearing Ratio (CBR) value of subgrade soils for pavement design and construction (for example Livney 1987, Kleyn 1982, Scala 1956). Some attempts have been made to extend the use of the DCP to determine the allowable bearing capacity of shallow foundations. Ampadu (2005) cor-

related the allowable bearing stresses computed from the Terzaghi equations with the DCP results for two lateritic soils. Sanglerat (1972) used a semi-empirical approach to derive an equation for computing the allowable bearing stress from the DCP readings. Sowers & Hedges (1966) produced a correlation between the DCP readings and the SPT N-values.

This study contributes to the search for a reasonable correlation between the allowable bearing stress and the DCP test results through the use of a model footing. A 300mm x 150mm wooden model footing was loaded on the surface of a compacted lateritic soil in a perspex box. The failure stresses determined from the stress-penetration curves for different densities ranging from 1.3 Mg/m³ to 1.8Mg/m³ were compared with those computed from the Terzaghi equation and correlated with the corresponding DCP readings. The results were discussed with other correlations.

2 METHODOLOGY

2.1 Equipment:

The mould for the model footing consisted of a perspex box with 16mm thick walls and internal dimensions of 609mm x 300mm and 376mm high. In order to minimize lateral yield-

ing during the compaction and during the loading test, the mould was braced on the outside using three 5mm x 25mm steel strips. The model footing was a solid wooden block 300mm long and 150mm wide and 50mm thick. The base of the model footing was made rough by gluing a grade 60 sand paper to the base. The triaxial frame was used for loading. The load was applied by the rising loading piston at the bottom and measured by a proving ring at the top. The displacement was measured using a dial gauge as shown in Fig. 1.

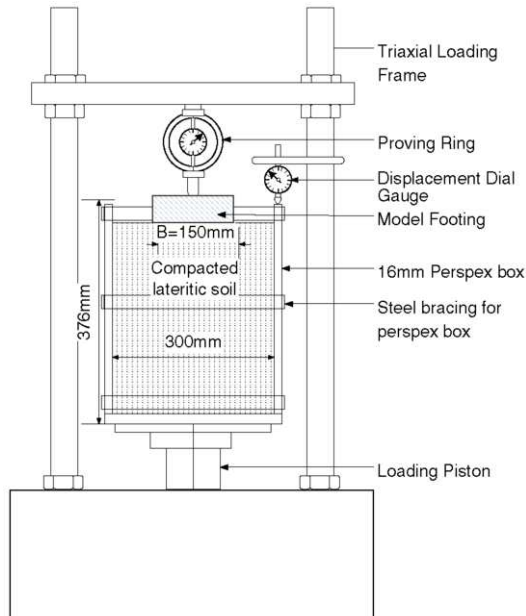

Fig. 1. Loading arrangement for model footing

The essential features of the DCP equipment used in this study have been described in Ampadu (2005) and it consists essentially of an 8kg metal hammer falling through a vertical distance of 575mm to strike a metal anvil to drive a 20mm, 60° cone at the end of a 16mm rod into the formation. This equipment has the same energy per blow per unit cone area of 144kN-m/m² as in Ampadu (2005) except that the former had a 10kg hammer falling through a vertical distance of 460mm. The penetration is measured using a scale along the rod.

2.2 Sample Preparation

The subgrade material used in this investigation was obtained from a depth of 0.30m to 0.80m in a trial pit manually excavated near the College of Engineering, on the University campus. The bulk samples were air-dried for 72 hours to a constant water content and sieved through the 19mm BS sieve. Samples were taken for the index property tests and for the compaction characteristics using the Standard Proctor specification (ASTM D698-00).

About 120kg of the sample were divided into four portions and mixed thoroughly with the quantity of water corresponding to the optimum water content. The mixture was put back together in a large container and mixed again and covered with a polythene sheet and allowed to cure for 16hours for moisture content equilibration. The cured material was then used to fill the perspex mould in six layers, each of approximate thickness 0.5m and each layer given a specified number of blows of a 6kg wooden rammer fabricated for the purpose. In this investigation six different samples were prepared with 15, 20, 30, 35, 100 and 150 blows respectively.

The perspex mould filled with the prepared material was then lifted by means of a hoist onto the triaxial frame. The wooden model footing was placed centrally on the sample

and the proving ring and the dial gauge were set. The model footing was then loaded at a rate of 0.375mm/min and load and displacement readings taken at appropriate intervals until a displacement of about 40mm was achieved.

At the end of the loading the perspex mould was removed from the frame, placed on the floor and the DCP test was performed at two locations off one end of the footprint of the model footing. For this test the DCP equipment was held upright and the hammer was allowed to drop onto the anvil. For each drop, the penetration was recorded. The test was terminated when an appropriate penetration had been obtained. Finally a metal tube was pushed into the soil in the mould to core samples for triaxial testing at a location off the opposite end of the footprint of the model footing. The triaxial samples were subjected to the undrained triaxial compression test.

3 DISCUSSION OF RESULTS

3.1 The Characteristics of Test Material

The grading characteristics of the material used for this study are shown in Fig. 2 while Fig. 3 shows the compaction characteristics. The basic index parameters are summarized in Table 1. The soil may be described as a *sandy clay with some silt* and it showed a trace of muscovite mica.

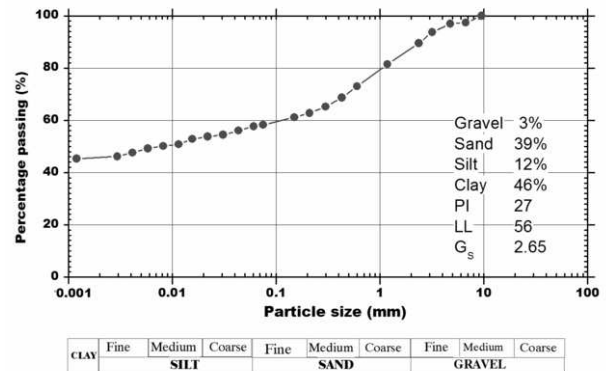

Fig. 2. Grading characteristics for test material

Table 1. Summary of basic properties of test material

Atterberg Limits		Gs	Compaction	
LL	PI		OMC (%)	MDD (Mg/m ³)
56	27	2.65	19.0	1.68

The starting conditions for each of the six tests in this investigation are superimposed on the Standard Proctor compaction curve for the test material in Fig. 3 and summarized in Table 2. The water content values are the average values of the water contents at the top, middle and bottom of the material prepared in the perspex mould. It can be seen that the average water contents were within 1% of the OMC and can therefore be assumed to be effectively constant at the OMC during this test.

The results of the triaxial tests showed that many of the tests did not indicate a clear maximum deviator stress. For such samples, failure was defined at 20% axial strain. The values of the undrained shear strength parameters, c_u and ϕ_u , derived from the tests are also shown in Table 2. It can be seen that whereas the cohesion intercept, c_u , increased with increasing dry density, the angle of internal friction was constant at 13° irrespective of the dry density, except for Test BC-15 which showed a slightly lower value. These results confirm those of Ampadu (2007) that for subgrade material of such high fines content, ϕ is not sensitive to the dry density.

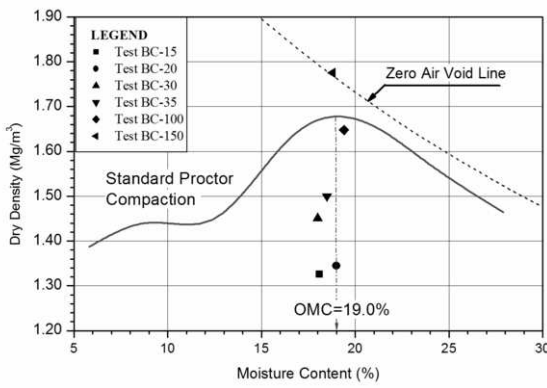

Fig. 3. Grading curves for two soils tested in the laboratory

Table 2. Initial and strength properties of test samples

Test Name	Water Content (%)	Dry Density (Mg/m ³)	c _u (kN/m ²)	φ _u (°)
BC-15	18.1	1.326	126	11
BC-20	19.0	1.345	135	13
BC-30	18.0	1.451	144	13
BC-35	18.5	1.500	149	13
BC-100	19.4	1.648	199	13
BC-150	18.8	1.775	208	13

3.2 Model Test Results

During the model tests significant punching of the footing into the model ground occurred with no observable bulging of the top of the model ground. The stress-settlement curves for the model footings are shown in Fig.4 for all the tests. The displacement measured by the dial gauges were corrected for the compliance of the proving ring by subtracting the compression of the proving ring as measured by the proving ring dial gauge.

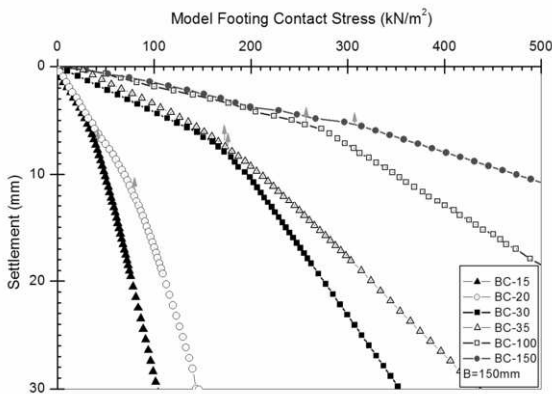

Fig. 4. Stress-settlement curves for Model Footing

The modes of failure were local shear failure. The stress-settlement curves show two sections, an initial linear portion followed by the final linear portion. The failure stress for the model footing is taken to be the yield stress, q_y, defined as the contact stress corresponding to the point of intersection of the tangents to the initial and final portions (Consoli et al 1998). This stress corresponds to the onset of permanent soil deformation and the fact that the final portion is linear suggests a strain hardening behavior where additional loading does not reduce the stiffness. The values of the contact stress, q_y and the corresponding settlement s_y defining the failure points are shown in Table 3. It can be seen that with the possible exception of test BC-20 which had a larger yield settlement of

11.1mm all the other tests showed similar values of yield settlement of between 5.1mm and 7.5mm giving s/B values at failure of between 3.4% and 7.4%. These values are comparable to those obtained for sand (Dr =75%) of 6-8% (Das & Omar 1994). The initial stiffness values of the stress-displacement curves defined as the gradients of the initial portions of the curves increased linearly with increase in dry density.

3.3 Bearing Capacity

The ultimate bearing capacity, q_{ult}, of the model footing on the model ground was also computed using the Terzaghi approach assuming local shear failure and taking into account shape factors, s_c and s_γ. Since the footing was surface loaded the q_{ult} values were computed from Equation (1).

$$q_{ult} = \left(\frac{2}{3} c_u N_c s_c + \frac{1}{2} B \gamma N_\gamma s_\gamma \right) \tag{1}$$

The bearing capacity factors N_c, and N_γ were obtained using the φ values obtained from tan φ =2/3tanφ_u where φ_u are the values in Table 2 and taking B/L=0.5, s_c=1.13 and s_γ=0.80. The contribution of the second term of Equation 1 to the value of q_{ult} is negligible. The q_{ult} values are tabulated in Table 3 and also plotted against the model footing failure stresses in Fig 5. The relationship appears linear. The ratio of the ultimate bearing capacity to the model failure stress varies from as much as 18 for the low density soil (BC-15) to about 5 for higher density soil (BC-150). A similar trend was obtained in a plate loading test on lateritic ground except that the ratio of the two stresses was of the order of 3 (Costa et al 2003).

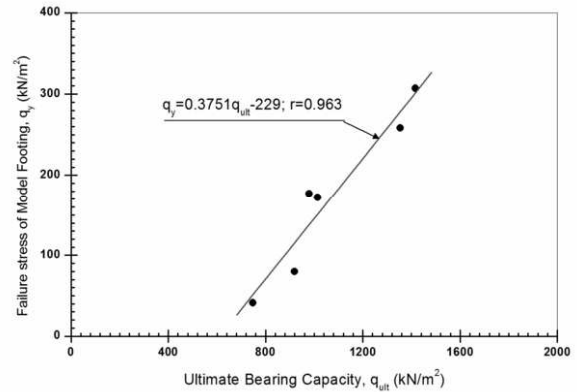

Fig. 5. Relationship between Model failure stress and Terzaghi ultimate bearing capacity

3.4 DCP Test Results

The DCP penetrations are plotted against the cumulative number of blows for all the tests in Fig.6. Each point is the average of the two penetration tests. The Dynamic Penetration Index, DPI, for a particular test is defined as the gradient of the cumulative number of blows-penetration curve for the test. These values are tabulated in Table 3. In the field, however, it is the number of blows required to achieve a 100mm penetration that is recorded. This is defined as the DCP-n value and it is obtained by dividing 100 by DPI to obtain the value in blows per 100mm. It may be observed that the DPI increases with dry density. The relationship between the DPI and dry density is presented in Fig 7 in the form of the level of compaction-DPI plot. Apart from tests BC-15 and BC-20 the relationship is linear in a log-log scale and is consistent with field compaction results obtained by Ampadu and Arthur (2006). The reason for the deviation of BC-15 and BC-20 from the linear trend is not immediately clear.

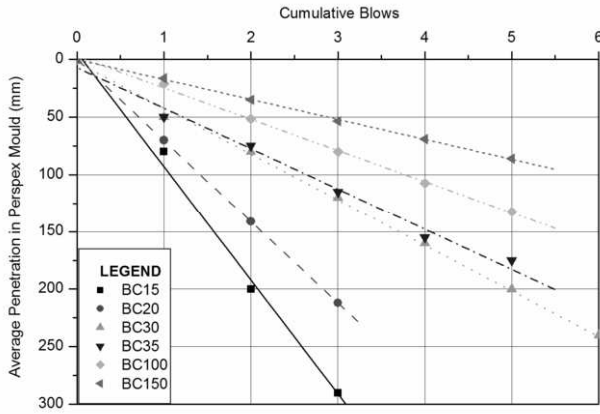

Fig. 6. Cumulative blows penetration tests for DCP Test

Table 3. Summary of Model and DCP Tests Results

Test Name	q_y (kN/m ²)	s_y (mm)	q_{ult} (kN/m ²)	DPI (mm/blow)	DCP n-Value (Blows/100mm)
BC-15	41.2	6.5	748	99	1.0
BC-20	79.9	11.1	919	70.7	1.4
BC-30	177.0	7.5	980	39.8	2.5
BC-35	172.3	6.6	1014	35.1	2.8
BC-100	258.2	5.1	1354	24.9	4.0
BC-150	307.2	5.4	1416	17.2	5.8

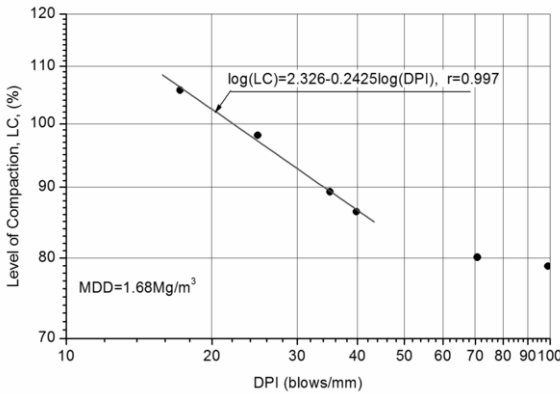

Fig. 7. Relationship between Level of Compaction and DPI

3.5 Correlations

The model failure stresses measured and the ultimate bearing stresses computed by the Terzaghi approach were converted into allowable stresses by dividing by a factor of safety of 3. The values are plotted against the corresponding DCP-n values in Fig. 8 together with the other correlations. The regression analysis of the allowable bearing stresses excluding tests BC-15 and BC-20 gave Equations (2) and (3) respectively for the model footing and for Terzaghi approach.

$$(q_{allow})_{model} = 14.2n + 22.6 \tag{2}$$

$$(q_{allow})_{Terz} = 46.2n + 222.3 \tag{3}$$

It can be seen that the model footing tests give relatively lower values of allowable bearing stresses compared with all the other correlations except the results of Sowers & Hedges (1966). It must be pointed out that the latter used equipment with much smaller energy per blow per unit cone area of only 30 kNm/m², compared with 144 kNm/m² used in this investigation. Within the range of n-values studied, the results predicted by the Terzaghi equations in this study were comparable to those by Cerns & McKenzie (1988) but higher than those by Sanglerat (1972).

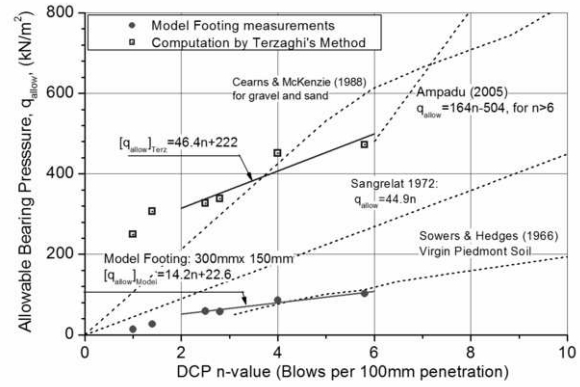

Fig. 8. Allowable bearing pressure DPI correlations

4 CONCLUSIONS

Based on the results of a model footing on re-moulded lateritic subgrade material and triaxial and in-mould DCP test on the model ground, it may be concluded that the model footing gave much lower allowable stresses than those predicted by Terzaghi bearing capacity equation.

REFERENCES

ASTM D698-00, 2000, "Test Method for Laboratory Compaction Characteristics of Soils using Standard Effort," Annual Book of Standards

Ampadu, S.I.K., 2007. "An investigation into the effect of water content on the direct shear strength characteristics of remoulded soil" 14th African Regional Conference for Soil Mechanics and Geotechnical Engineering, Yaounde, Cameroon 26-28th November 2007, pp 23-30

Ampadu, S.I.K. and Arthur, D.T. 2006, "The Dynamic Cone Penetrometer in Compaction Verification on a Model Road Pavement". Geotechnical Testing Journal, Volume 29, No. 1, GTJ 12306, pp 70-79, January 2006.

Ampadu, S.I.K. 2005, "A correlation between the Dynamic Cone Penetrometer and the bearing capacity of a local soil formation". Proceedings of the 16th ICSMGE, September 12-16th Osaka, Japan, Millpress Science Publishers, Rotterdam, Netherlands

Cerns, P.J. and McKenzie, A., 1988, "Application of Dynamic Cone Penetrometer in East Anglia," Proc. of the Symposium on Penetration Testing in the UK, Thomas Telford, London, 123-127 pp

Consoli, N.C., Schaid, F., and Milititsky, J., 1998, Interpretation of Plate Load Tests on Residual Soil Site" Journal of Geotechnical and Geoenvironmental Engineering, ASCE Vol. 124, No. 9 pp 857-867.

Costa Y.D., Cintra J.C. and Zornberg J.G., 2003, "Influence of Matric Suction on the Results of Plate Load Tests Performed on a Lat-eritic Soil Deposit", Geotechnical Testing Journal Vol 26, No. 2, 1-9

Das B.M. and Omar M.T., 1994, "The effects of foundation width on model tests for the bearing capacity of sand with geogrid reinforcement", Geotechnical and Geological Engineering, 12, 133-141.

Kleyn, E.G., 1975 "The Use of the Dynamic Cone Penetrometer (DCP)," Report No. 2/74 Transvaal Road Dept, South Africa.

Livneh, M., 1987, "Validation of Correlations between a Number of Penetration Tests and In Situ California Bearing Ratio Tests", Transportation Research Record 1219, Transportation Research Board, Washington D.C., 56-67 pp.

Sanglerat, G., 1972, "The Penetrometer and Soil Exploration-Interpretation of Penetrometer Diagrams-Theory and Practice", Elsevier Scientific Publishing Company

Scala, A.J., 1956 "Simple Methods of flexible pavement design using cone penetrometers," New Zealand Engineer, Vol. 11, No. 2, pp. 33-44.

Sowers, G.F. & Hedges, C.S., 1966 "Dynamic Cone for Shallow In-Situ Penetration Testing," Vane Shear and Cone Penetration Resistance Testing of In-Situ Soils, ASTM STP 399, ASTM, pp. 29.