

# INTERNATIONAL SOCIETY FOR SOIL MECHANICS AND GEOTECHNICAL ENGINEERING



*This paper was downloaded from the Online Library of the International Society for Soil Mechanics and Geotechnical Engineering (ISSMGE). The library is available here:*

<https://www.issmge.org/publications/online-library>

*This is an open-access database that archives thousands of papers published under the Auspices of the ISSMGE and maintained by the Innovation and Development Committee of ISSMGE.*

## Evaluation of earthfill parameters from Gavoshan dam with back analysis during construction

### Evaluation des paramètres des remblais du corps de barrage de Gavoshan , par analyse du retours de la période de construction

Mohammad Pakbaz

Department of civil engineering, University of shahid chamran, Ahvaz, Iran  
 e-mail:mpakbaz@yahoo.com

Mahdi Zolfagharian

Graduated of M.S. University of shahid chamran, Ahvaz, Iran  
 Responsible of Gavoshan dam instrumentation  
 e-mail:zolfagharian\_m2000@yahoo.com

#### ABSTRACT

Instrumentation of dams very significant in all large dams by installing instruments as pore Water pressures, earth pressures and displacements ,during construction, first impounding and operation are measured and the performance of dams are evaluated and analyzed . In this paper the performance of Gavoshan dam in the west of Iran during the construction is evaluated with the help of the results of instrumentations. The performance of the dam in the future is also predicted using the result of numerical analysis. During this research it is observed that the performance of dam during the construction in terms of the magnitude of pore water pressures, the coefficient of pore water pressure " $r_u$ ", displacement, stresses and the amount of developed arching has been appropriate in comparison with the performance of similar dams in Iran and in the world, and it is in safe condition. Also in back analysis, better parameters for core, transition and shell materials is obtained. Using these parameters the performance of the dam at the end of construction predicted.

#### RÉSUMÉ

L'instrumentation de barrage a une importance capitale . Dans tous les grands barrages, en utilisant des appareils de mesure de la pression de l'eau de pénétration par porosité, les pressions des remblais, les déformations durant la période de construction, de la première endiguement et en fonctionnement, sont mesurés. Et la performance de barrage est évaluée et analysée. Dans cet article, le comportement de barrage Gavoshan, à l'ouest de l'Iran est évalué à l'aide des résultats de l'instrumentation ( mesure par appareillage). Et le fonctionnement futur de barrage est aussi calculé à l'avance en utilisant le résultat de l'analyse numérique. Durant cette recherche, on a observé que la performance de barrage, durant la construction, exprimée en grandeur de pression de l'eau pénétrée par porosité, le coefficient de cette pression d'eau, le déplacement, les tensions (contraintes) et la quantité de courbure créé, ont été convenables. Et en comparaison avec les performances des barrages identiques ( similaires) en Iran et au monde, elle est dans des conditions de bonne sécurité . De même, en analyse de retours, meilleurs paramètres pour le noyau, la transition et les matériaux de paroi, sont obtenus. En utilisant ces paramètres, le comportement ( la performance) de barrage en fin de construction, a été prévu.

#### 1 INTRODUCTION

Dams are very significant economically, socially and politically. The role of dams in developing agriculture, rural and urban areas, supplying water, producing electricity and control of rivers is very important. Because of high cost of construction of dams and also danger of instability of dam the problem of continues evaluation of stability of dams is important .The increase in safety of dams will increase the cost of the construction. Therefore assurance of stability of dam during design, construction

and operation is essential. To assure an appropriate behavior of earth dams in different condition during construction, filling and operation is essential. Because of unreliability that exists in assumptions made in design stage, evaluation of behavior of dams and the agreement between the analysis and design parameters in different conditions during the life time of the dam is essential. This target is achieved with the help of information obtained from instrumentation(ASCE, 2000; ICOLD / CIGB, 1989; USACE .1995).

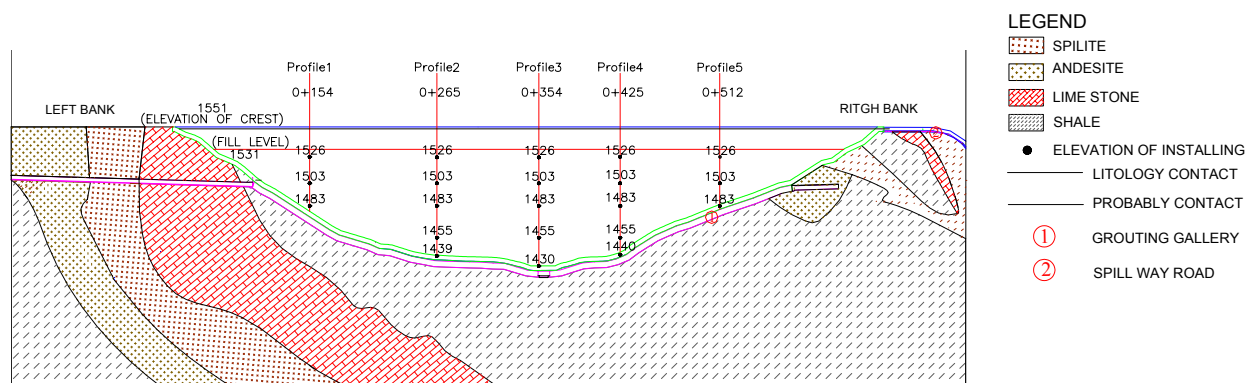

Figure 1. Longitudinal section of dam body

Gavooshan dam on the Gaveh river the Kurdistan province is under construction .The dam is a rockfill type with a central clay core and is 123m high with the crest length of 650m and reservoir volume of about 550mi m3 . The dam is instrumented in five different sections. The instruments used included piezometers, total pressure cells, displacement measuring device (magnetic plates) and inclinometers .figure 1 shows a longitudinal section of the dam with instrumented sections and foundation material properties.

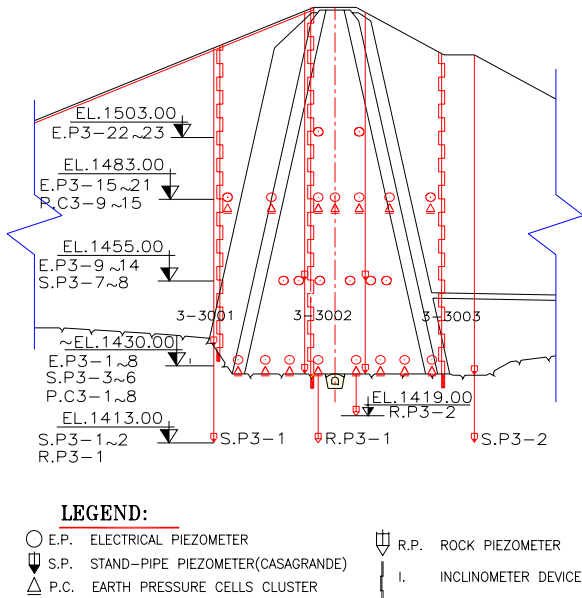

Figure 2. Transverse third instrumented section

In order to evaluate the behavior of the dam in addition to the results of instrumentation program a back analysis with the-Plaxis were also performed. In this analysis an elsto-plastic Mohr-coulomb model were used. The material properties which were predicted according to the back analysis with the help of measured data are shown in table 1(ICOLD/CIGB, 1994). This analysis were performed on third section at station 0+365. Figure 2 shows a transverse third section of the dam with instruments installed.

Table 1: Material property of dam body

Property of material	Unit	Clay	Filters, Drain & Transition	Rockfill
Dry Density	KN/m <sup>3</sup>	17.5	20	22.6
Wet Density	KN/m <sup>3</sup>	20.7	21.2	23.8
Angle of Shearing Resistance	degree	30	36	43
Cohesion	KN/m <sup>2</sup>	50	0.5	0.5
Elastic modoul	KN/m <sup>2</sup>	16000	26000	33500
Poison Ratio		0.33	0.26	0.2
Angle of Dilatancy	degree	0	5	8
Permeability	m/s	$K_x=1E-9$ $K_y=4E-10$	5E-5	5E-5

## 2 RESULTS

### 2.1 Vertical displacements (settlements)

In order to measure vertical displacement in clay core, upstream and downstream of central core, three inclinometers were installed .Along these inclinometers and at different levels at distances of 3.76m, magnetic plates were installed .In fig 3 the pattern of vertical displacements obtained form analytical model

fitted to the measured data on Feb 2003 at the time when the height of the dam was at 103m is shown.

In Figs 4,5,6 the measured displacements with the result of analytical model at clay core, upstream and downstream of clay core in terms of time with the progress of fill construction is shown.

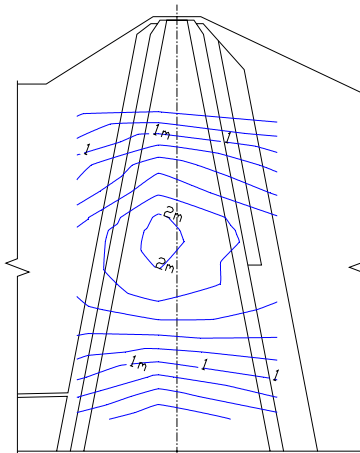

Figure 3. Pttren of vertical displacement

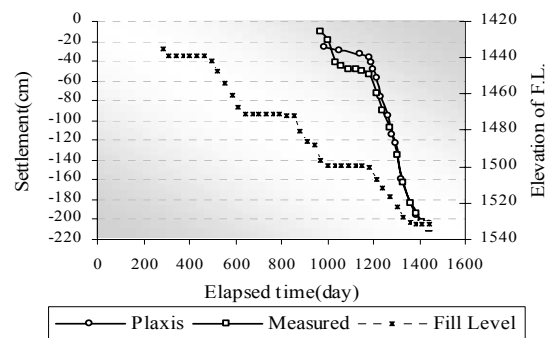

Figure 4. Settlement plate positioning (20<sup>th</sup>) in clay, elevation of installing: 1494.17

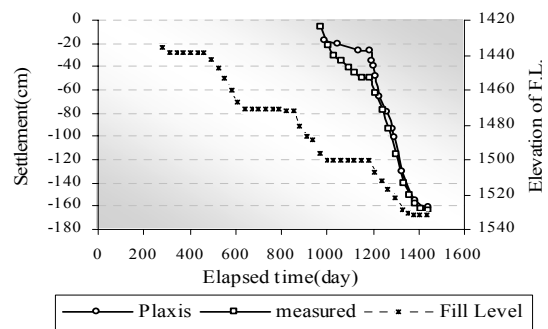

Figure 5. Settlement plate positioning (20<sup>th</sup>) in upstream of clay, elevation of installing: 1494.28

In fig 7 the measured displacements and those predicted by the model at the top of the core on Feb 2003 are compared. As it can be seen the maximum displacement in both cases is the same and is equal to 209 cm about 2 % of the height of the fill. In figs 8 and 9 the measured displacements and analytical model at the top of core upstream and downstream on Feb 2003 are compared. As it can be seen in fig.8 the maximum displacements obtained in both case is equal to 165cm which is about 1.6% of the height of the fill. In fig 9 also it can be seen that maximum displacements for both case is equal to 170 cm which is about 1.7% height of the fill. In fig 10 predicted settlement in three sections in end of construction is shown. In overall evaluation of displacements it is noted that the magnitude of maximum displacement although in the acceptable range but it is about on the high boundary of the range of published data

which is due to the fact that core material were compacted wet of optimum water content(Kutzner, 1997; Penman et al ; Sherard et al ,1976).

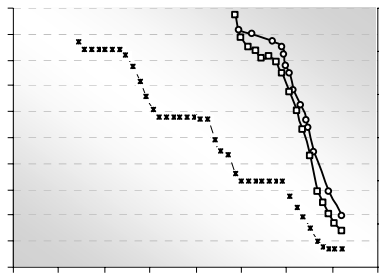

Figure 6. Settlement plate positioning (20<sup>th</sup>) in downstream of clay, elevation of installing: 1494.32

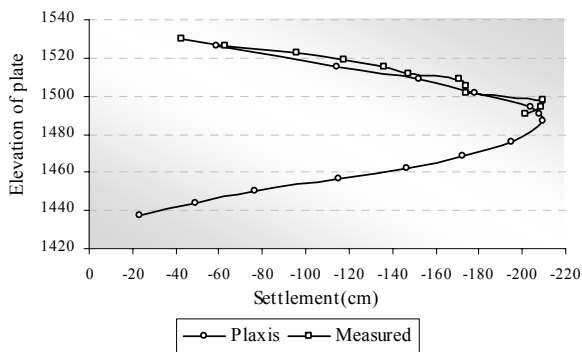

Figure 7. Settlement plates positioning in clay (Feb 2003)

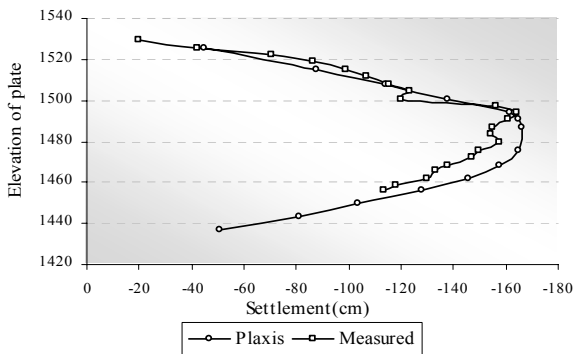

Figure 8. Settlement plates positioning in upstream of clay (Feb 2003)

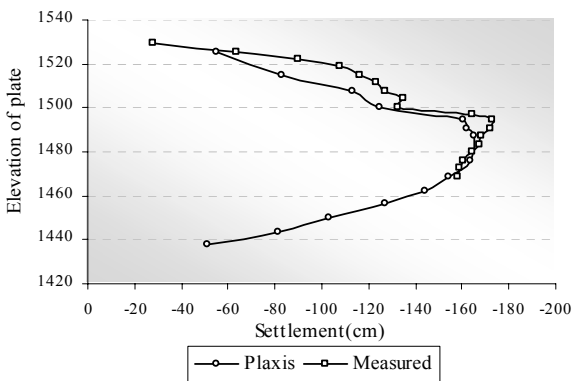

Figure 9. Settlement plates positioning in downstream of clay (Feb 2003)

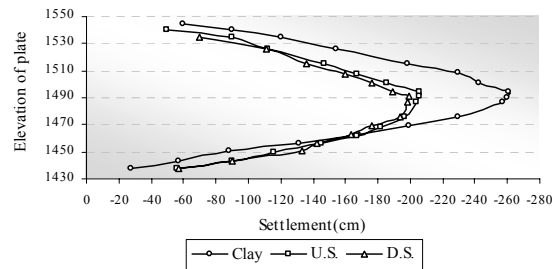

Figure 10. Predicted settlement in dam body in end of construction

## 2.2 Pore water pressures

Because in the software Plaxis we can not model unsaturated soil with assumption of 100% saturation, the pore water pressures obtained in analytical model are higher than the actual values. In fig 11 the actual measurement of pore water pressure are compared with those obtained in numerical analysis for three different level of installation. As it can be seen at the center of the core the measured and the model values compared but at distances away from the center the model values are lower than the measured value.

In fig 12 the pore water pressure ratio  $r_u = u_w / \gamma H$  is plotted against the time for three level of installation. In this plot the measured  $r_u$  is also given for the first stage of construction. The measured  $r_u$  is obtained by dividing the measured pore water to the measured earth pressure. As it can be see the maximum calculated  $r_u$  in the first level is 0.46, in the second level is 0.71 and in the third level is 0.58. These values when compared whit those in the literature was appropriate and they indicate the safety of the dam(Kutzner, 1997; Penman et al ; Sherard et al ,1976). Predicted pore water pressure in clay in end of construction in fig 13 is shown.

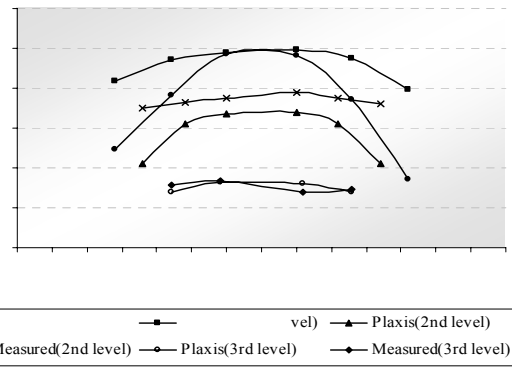

Figure 11. Pore water pressure in clay in 1<sup>st</sup>, 2<sup>nd</sup> and 3<sup>rd</sup> level of installation (last reading-Feb 2003)

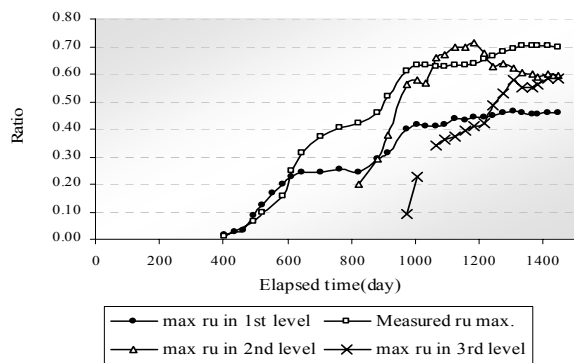

Figure 12. Maximum ratio of pore water pressure in clay

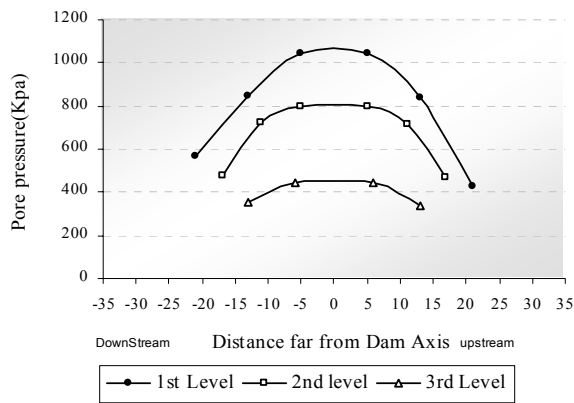

Figure 13. Predicted pore water pressure in clay in end of construction

### 2.3 Earth pressures

In fig 14 the measured and the model earth pressures in the first level of installation in Feb 2003 are compared. In same fig comparison for the third level of installation in Aug 2003 is shown. One of important problem in earth dam is the arching phenomenon. This is the hanging of the core material to the shell material that causes decrease of vertical pressure in the core. If the arching is severe the possibility of hydraulic fracturing of the core material during impounding exists. Figure 15 the measured and model arching coefficients along the dam transverse section are shown and compared in the first and the third level of installation.

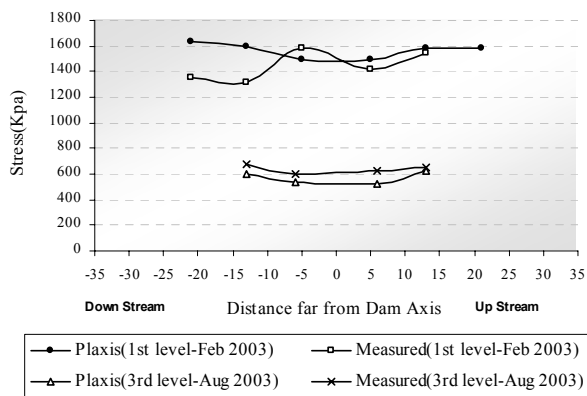

Figure 14. Vertical total stress in clay in 1<sup>st</sup> level, 1430 masl and 3<sup>rd</sup> level, 1483 masl, of installation

As it is shown the average measured arching coefficient in the first and third level is 0.7 and 0.9 respectively. These values of arching coefficient are appropriate values and therefore the dam is considered safe with regard to this problem (Kutzner, 1997; Penman et al; Sherard et al, 1976). In fig 16 predicted arching coefficients in end of construction and those measured on Feb 2003 are compared.

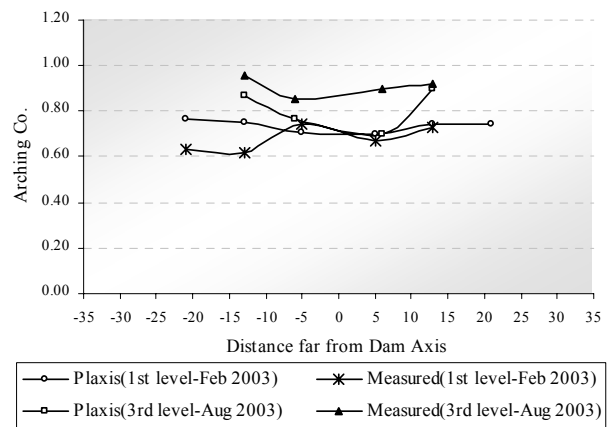

Figure 15. Arching coefficient in clay in 1<sup>st</sup> and 3<sup>rd</sup> level of installation

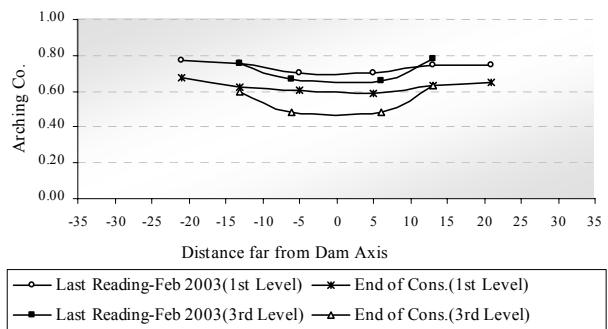

Figure 16. Predicted arching coefficient in clay in 1<sup>st</sup> and 3<sup>rd</sup> level of installation

### 3 CONCLUSION

According to discussion given in the previous sections following conclusions are reached.

The maximum displacement observed at three sections (the clay core, upstream and downstream of central core) from the inclinometers, the magnitude and the locations are according to the published literature. Also according to numerical analysis the trend of increase in displacement in future follow the trend of fill construction and no problem is foreseen.

The pore water pressure ratios  $r_u$  at different levels are in an acceptable range.

The coefficient of arching is high and acceptable as compared with other cases in the world and the dam is a safe condition with this regard.

Prediction of settlement, pore water pressure and total earth pressure in end of construction shows the dam will be in safe condition.

### REFERENCES

- ASCE, 2000. Guidelines for Instrumentation and Measurements for Monitoring Dam Performance, publication ASCE.
- ICOLD / CIGB, 1989. Monitoring of Dams and Their Foundation, Bulletin 68, ICOLD/CIGB, Paris.
- ICOLD/CIGB, 1994. Embankment Dams, Granular Filters and Drains. Bulletin 95, ICOLD/CIGB, Paris.
- Kutzner, c. 1997. Earth and Rockfill Dams, Principals of Design and Construction, A.B Balkema.
- Penman A.D.M., Saxena K.R. and Sharma V.M. Instrumentation, Monitoring and surveillance, Embankment Dams. A.A. Balkema.
- Sherard J.L., Woodward R.J., Gizienski S.F, and Clevenger W.A. 1976. Earth and Earth - rock Dams. wiley & sons.
- U.S. Army Corps of Engineers (USACE) .1995. Instrumentation of Embankment Dams levees, Engineer manual, NO.1908.