

INTERNATIONAL SOCIETY FOR SOIL MECHANICS AND GEOTECHNICAL ENGINEERING



This paper was downloaded from the Online Library of the International Society for Soil Mechanics and Geotechnical Engineering (ISSMGE). The library is available here:

<https://www.issmge.org/publications/online-library>

This is an open-access database that archives thousands of papers published under the Auspices of the ISSMGE and maintained by the Innovation and Development Committee of ISSMGE.

Cement silo – Correction of tilt

Silo en ciment – Correction de l'inclinaison

S. Geffen & I. Birnbaum – *S. Geffen Soils Eng. Ltd., Kfar Saba, Israel*

ABSTRACT: A silo with a capacity of 100,000 kN cement, was constructed in 1991, at the Nesher plant near Haifa, Israel. The soil investigation indicated saturated plastic clays to 22 m followed by 3-5 m of sand. The silo is based on a shallow doughnut shaped raft foundation. Shortly after the filling, large settlements and tilt occurred. After 3.4 years, the differential settlement reached 285 mm (1:73) and a remedial measure was taken. Slanted borings were drilled on the less tilted side and left void. For 1.8 years, the tilt decreased by 33 mm. During the following 2.5 years, the leaning increased again to 270 mm. Then, additional vertical borings were drilled. The differential settlement decreased sharply by 84 mm. Presently, the silo is straightening at the rate of almost 1 mm/month.

RÉSUMÉ: Un silo de ciment, situé à Nesher près de Haïfa Israël d'une capacité de 100,000 kN a été construit en 1991. La reconnaissance du sol de fondation a montré l'existence sous le terrain naturel d'une couche d'argile plastique saturée sur 22 m d'épaisseur reposant sur une couche de sable de 3 à 5 m d'épaisseur. Le silo est fondé sur un radier annulaire. Peu de temps après le début de son remplissage, un tassement important de l'ouvrage s'est produit, ainsi qu'une inclinaison. Trois ans et demi plus tard, le tassement différentiel atteignait 285 mm (1:73) et des mesures ont dû être prises pour redresser cette situation. Des forages inclinés ont été exécutés au droit du côté de l'ouvrage qui a le moins tassé afin d'affaiblir le sol en laissant des vides à cet endroit. Après 1.8 an environ, l'inclinaison diminua de 33 mm. Durant les 2 ans ½ qui suivirent, l'inclinaison augmenta jusqu'à atteindre 270 mm. Alors des forages supplémentaires ont été exécutés. Le tassement différentiel diminua brusquement de 84 mm. Actuellement, le silo se redresse avec presque une vitesse de 1 mm/mois.

1 INTRODUCTION

A silo 40 m in height and 20 m in diameter, having a dead weight of 40,000 kN and an approximate capacity of 100,000 kN, was completed in 1991 at the Nesher plant, near Haifa, Israel. Since the beginning of operations, the foundation of the silo experienced erratic loading and unloading due to the changing activity of filling and emptying of cement. After three months of normal use, differential settlement of the silo reached 100 mm. This tilt caused slight eccentricity of the load.

During the following months, the settlement rate decreased but the inclination continued. When the maximum differential settlement reached 285 mm, remedial measures were taken.

The corrective activities consisted of soil extraction from several inclined boreholes, which were left hollow. As a consequence, the tilt decreased by 12%. A few years later, when the differential settlement of the silo increased again to 270 mm it was necessary to proceed with a second corrective measure. A modified intervention was performed, which caused the tilt to decrease by 31% within 19 months.

This paper describes the method to overcome extensive differential settlements of a rigid structure. It analyses the straightening effect while evaluating the factors involved in the decrease of differential settlements.

2 SITE LOCATION AND SOIL PROFILE

The Nesher cement plant is located on the northeast side of the Carmel Mountains and in the southern portion of the Zvulun Valley. The site is adjacent to the Yagur fault, which produces weak earthquakes and whose frequencies are not yet fully understood (Hofstetter et al. 1996).

The soil survey for the silo included several exploration boreholes, which extended to a depth of 26 m below grade. The in-situ testing program included Standard Penetration Tests, extraction of undisturbed samples at various depths and ground-

water level observations. The laboratory-testing program included Atterberg limits, oedometer tests and triaxial tests. At an adjacent site some pressuremeter tests were performed up to a depth of 70 m. The soil strata are shown in Figure 1 up to a depth of 50 m and are described below.

The upper 22 m is a layer of clay (CH) of high plasticity, followed by a few meters of granular soil layer, partly cemented with lime. The liquid limit of the clay ranged between 72% and 96% and the plastic index from 32% to 58%. The groundwater table at the time was 3.5-3.7 m below ground surface. Oedometer tests showed some preconsolidation in the upper portion of the clay with overconsolidation ratios (OCR) of about 1.5 - 3.0.

It was found that the clay has a compression index $C_c=0.45$ and the rebound compression index $C_r=0.08$, effective cohesion $c'=17$ kN/m² and effective-stress friction angle $\phi'=19^\circ-23^\circ$ were figured out from consolidated-undrained triaxial shear tests. Pressuremeter tests showed an average undrained shear strength of 105 kPa at depths between 6 and 22 m. These strength parameters are slightly higher than the results obtained from a fundamental study on shear strength of Israeli soils and tests on clays from the Israeli continental slope (Frydman, 2000). The groundwater level is fluctuating of less than ± 1 m depending on the rainy seasons and the underground flow from the Carmel Mountains to the Zvulun Valley.

3 FEATURES OF THE SILO AND ITS SURROUNDINGS

The described silo no. 11 was built during the early months of 1991 and filling started later that year. Its centerline is located 25 m south from cement silo no. 9, which was built several years earlier and its capacity was increased in 1995. Silo no. 11 is based on a shallow doughnut shaped raft foundation, whereas silo no. 9 is based on a full circular raft foundation. The distance from the outer perimeter raft of silo no. 11 to the adjacent foundation of silo no. 9 is 3.7 m. The layout and the section of foundations of silos no. 11 and no. 9 are presented in Figure 2. It may

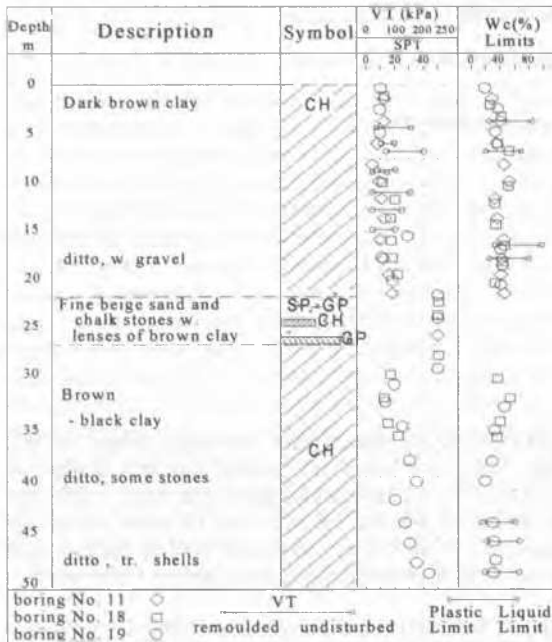

Figure 1. Soil profile: borings nos. 11, 18, 19, and from adjacent site.

be seen that the bottom of the foundation of silo no. 11 was 1.5 m below final grade and about 2 m above the bottom of the raft foundation of the second silo, no. 9. The soil to depth of 1.8 m below the foundation of silo no. 11 was replaced by granular compacted fill. The doughnut foundation measures an outside diameter of 25 m and a width of 5 m.

4 SETTLEMENTS AND STRESSES

Four level points for settlement measurements were fixed on the inner wall of silo no. 11, as shown in Figure 2. Measurements of the vertical movements were performed on a daily basis for about three months. Thereafter the frequency was decreased gradually to once a month; cement content by weight was and still is recorded on a daily basis. The silo reached its maximum capacity, 100,000 kN, within a short time after the start of filling. At that time the maximum tilt was measured in the NW-SE direction. As can be seen from Figure 2, the silo leaning was away from silo No. 9. Within a few more months the rate of settlement was 6 mm/month and the tilting rate continued to be about one half of that rate. The loads varied sharply between 40,000 kN (empty dead weight only) to 140,000 kN, at random frequency.

The proximity to silo no. 9 is believed to be detrimental due to two causes: a) the random loading and unloading of silo no. 9 caused a remarkable increase in the preconsolidation ratio of the upper clays which was already effective at the time silo no. 11 was built; b) the raft foundation of silo no. 11 was constructed on 1.8 m of granular fill material while some of the layers were stabilized with 5% cement. Base layers were compacted on top of medium hard clays with the exception of the site adjacent to silo no. 9 where already there existed the granular base layer on which the foundation of silo no. 9 was constructed.

It was found that close to silo no. 9 there was a specially large concentration of cement within the granular base material which became a hardened layer of concrete of 0.2 to 0.5 m width.

3.4 years after settlement observations started, the average settlement reached 370 mm and the differential settlement increased at a fast pace, reaching 285 mm, which amounts to a tilt of 1:73. This excessive leaning had to be stopped or at least decreased since there was the potential danger of the silo overturning, which would probably damage also silo no. 9.

In order to bring the silo back to safety, a remedial measure was planned and executed. This measure succeeded partially,

therefore after a few more years a new remedial measure was designed, taking in account the previous corrective experience.

Results of the full monitoring of settlement and tilt are plotted together with the loading history in Figure 3.

The total settlement can be assumed to be mainly due to three components: Immediate compression of the granular fill underlying the bottom of the foundation of silo no. 11, immediate compression of the clay layer and consolidation of the clay layer.

It has been mentioned that differential settlement occurred within a short time after commencement of loading. This caused an eccentricity of the loading in the silo, resulting in a slight non-uniform stress distribution on the foundation soil. If considering a uniform pressure distribution, the foundation imparts a mean contact stress of 445 kN/m² to the granular fill layer. Assuming linear load distribution with depth at a slope of 1 vertical to 2 horizontal the result is a bearing stress of 182 kN/m² on top of the clay layer. Calculating the ultimate bearing capacity of the clay layer, the factor of safety against bearing capacity failure varied between 1.45 and 1.95 depending on the applied bearing capacity analysis. Thus, deformation caused by local failure and/or plastic flow could not be the main cause of the excessive settlements. In addition, the cement distribution inside the silo was quite uniform, therefore the load distribution of the cement inside the silo did not contribute to the initial tilt. The insufficient horizontal distance between silo no. 11 and silo no. 9, Figure 2, is believed to be one of the main causes of the differential settlement. Since the granular soil layer beneath the foundation is not uniform and the section adjacent to silo no. 9 is approximately 1.5 m thicker than the opposite side, it can be deduced that the upper fill gave inconsistent support and therefore caused the initial tilt of the silo. An additional contribution to the initial tilt was the stress conditioning of the clay under silo no. 11 next to silo no. 9, due to the random loading and unloading of silo no. 9. This caused a certain preconsolidation, which resulted in smaller settlement at this location than at the opposite side of silo no. 11, furthest away from silo no. 9.

With the initiation of tilting, the top layer i.e. the highly plastic clay, started to contribute progressively to the differential settlement. As eccentricity progressed, it caused the redistribution of the bearing pressures and the uniform loading concept was no longer valid.

A theoretical solution for analyzing settlements, based on sinusoidal loading, was suggested by Rahal & Vuez (1998). In the lower chart of Figure 3, the loading history of silo no. 11 is indicated. For this random loading and unloading, a sinusoidal assumption is not valid. Using the logarithmic relation between plastic strain and number of cycles, as suggested by Ansal & Tunçan (1989), assuming that after long time the silo operation activity repeats itself, the predicted differential settlement for 10 years (equivalent to 3650 cycles), turned out to be 320 mm. It is not clear whether the loading of silo no. 11 could be viewed as cyclic.

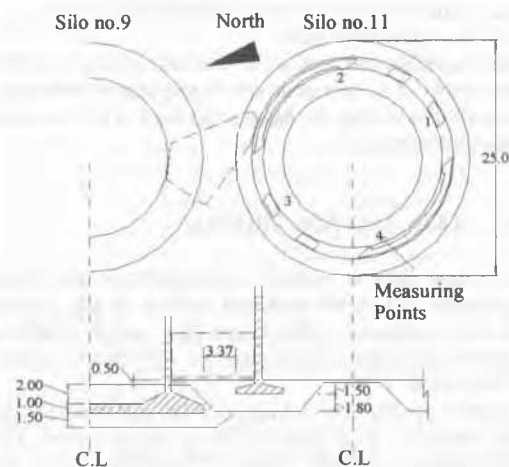

Figure 2. Layout and section of foundations.

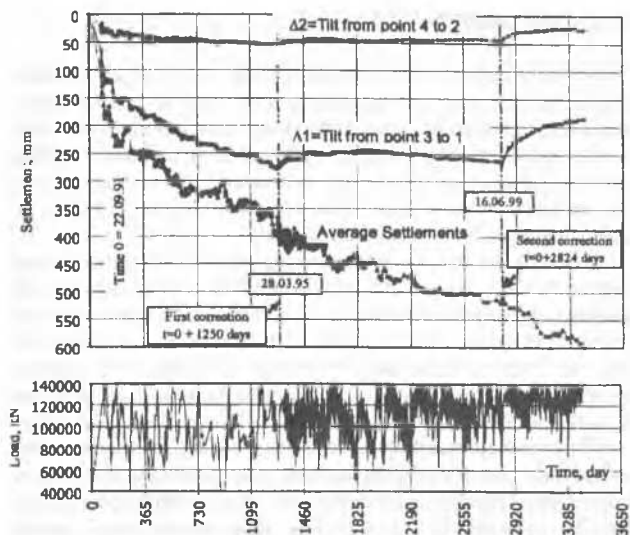

Figure 3. Settlement and tilt.

5 TILT CORRECTION DILEMMA

Any corrective action to decrease the tilt, had to take into consideration that no damage is to be caused to silo no. 9, nor to disturb the functionality of silo no. 11 or the cement plant in general. Several methods for the correction of the tilt were examined, e.g.: surcharge on the north (high) side, installation of supporting piled wall along the southern (lower) side, electro-osmosis, and controlled soil extraction. All these methods have been reported in literature with varying degrees of success. Surcharging was not adopted because of the lack of space on the north side, where a generator structure is located; also, it was thought that it could cause undesired tilt of the adjacent silo no. 9. Similarly, the electro-osmosis method was rejected because of the potential differential settlements that could affect the nearby silo no. 9.

After examining all of the relevant aspects of the mentioned corrective measures it was decided to employ soil extraction. This method has been used successfully at various locations, e.g.: in Mexico City, where many historical buildings had been affected by differential settlements (Terracina 1974); a grain silo in Mashad, Iran, (Amirsoleymani 1991), and is currently under execution at the leaning tower of Pisa (Burland 1995, Jamiolkowski et al. 1991). The corrective measures adopted for silo no. 11 were somewhat different than the methods employed in the above mentioned examples.

The greatest tilt of 280 mm was in the direction of the reference points 1-3. However, a differential settlement of 52 mm was observed from 4 to 2, which had to be accounted for. This meant that the major tilt was really directed slightly to the North and the absolute differential settlement at the foundation level, was 285 mm.

6 CORRECTION OF TILT

6.1 First corrective measure

As indicated before, at the time the total differential settlement reached 285 mm, a radical intervention was due. This happened about 3.4 years after the commencement of measurements. The following procedure was adopted: the silo was unloaded to an overall load (dead and partial live load) of 60,000 kN. Five boreholes were drilled, each with a diameter of 0.6 m, to a depth of 13 m, at an inclination of 63° from the horizontal towards the center of the footing. The boreholes were left void of soil. The direction and location of a typical borehole is indicated in Figure 4.

The drilling penetrated the upper granular fill, and then into the clay layer. The total weight of the extracted soil was 330 kN but the effective part of the holes, which is under the foundation level was only 70% of the indicated weight, which is equivalent to an approximate volume of 14.5 m³.

The correction of the tilt worked in the right direction, however it dwindled to a stop after about 650 days and then the tilt resumed. The differential settlement increased at about 1 mm/50 days, until it reached again 270 mm, when a second correction measure had to be performed. The first correction succeeded in returning the foundation from a maximum differential settlement of 285 mm to 251 mm, which is about 12% of the maximum out of level. During all this time the average settlement continued as before, without showing any increase in pace which was at the time about 6 mm/year.

6.2 Second corrective measure

The second corrective measure started 7.7 years after the completion of the construction of the silo. It consisted of 12 vertical boreholes, 0.6 m in diameter, drilled to a depth of only 5 to 6 m (Fig. 4). The boreholes were closely spaced along the less settled portion of the circular arc of the foundation perimeter. The effective volume of extracted soil, 22 m³, was 1½ times the volume extracted during the first corrective measure.

The second corrective measure was intended to cause a partial shear of the upper clay layer by inducing relatively large lateral movement of the soil towards the excavated boreholes. This condition necessitated careful reloading of the silo and daily monitoring of the settlements. As expected, the tilt decreased at a faster rate than after the first corrective measure, Figures 3 and 5. The average settlements continued to increase at a slightly faster pace.

19 months (570 days) after performing the second corrective measure, the differential settlement of the footing was 186 mm, compared with 270 mm measured before this correction took place. The settlement measurements of the silo, during the following months, indicated that the straightening was still taking place, but at the reduced rate of about 1 mm per 35 to 40 days.

7 COMMENTS

The differential settlement is the difference between the maximum and minimum settlements. The tilt is planar due to the rigidity of the construction.

The settled side beneath the footing could be viewed as a missing volume of soil. Then the upper side is the surplus soil. If it was possible to "shave" the soil from under the foundation, from the part which settled less, the silo would straighten completely, even if only for a short time; but, removing the soil horizontally from under the footing is not possible.

Soil removal by slanted boreholes seemed to be the closest simulation to shaving of the surplus soil. The holes were considered as additional voids that would fill gradually with soils within several months, due to the weight of the structure and the overburden pressure.

The computed volume of the truncated surplus of soil was 42 m³. The volume of effective voids from the slanted boreholes was limited to 14.5 m³, in order not to cause overturning of the silo. Thus, the volume relationship of the removed soil to theoretical volume of the truncated cylinder was 34.5% and as mentioned, the differential settlement improved only by 12%. The ratio between these percentages is 0.35 and this number could be considered as the effective factor for the solution employed, e.g. slanted boreholes.

The second correction was more "courageous". The effective soil removed was 22 m³, from the vertical boreholes which were shorter. The voids being closer one to another and within region of the highest foundation stresses, it was considered that a state of partial shear might occur.

The removal of 22 m³ of soil resulted in a rebound of 31%. The volume ratios of the removed soil vs. the truncated cylinder was 54%, therefore the effectiveness factor was 57% which is about the ratio between the extracted soil on the first corrective attempt to the second one. It is believed that the second attempt to straighten the structure was more successful than the first one while the correction of the tilt is still in progress, but at a slow pace. Voids around the footing of rigid structure cause settlements and tilt, or in this case, the correction of tilt. When planning the second correction method, it was believed that a partial shear will occur due to the weakening of the soil strata on one side of the foundation. It is not clear if this shear really happened; more reasonable is to assume that the clays were squeezed from under the foundation towards the voids. Therefore, the tilt may still decrease until all the voids will be filled. All the voids? This is a question without an answer at present. The effective part of the voids is not known and it is also not clear if the voids of the first remedial measure are or are not continuing to affect the settlements, together with the new vertical boreholes.

The time-settlement could not be predicted and remains an unknown factor. The decrease in the differential settlement for the second attempt was estimated at 70 mm which was about 26% of the total at the time. This was achieved after 280 days. However, the differential settlement continued to decrease, as mentioned before, even after 570 days.

From the technical point of view the decrease of tilting improved satisfactorily. Theoretically, the question marks are many and unfortunately could be answered now by assumptions only.

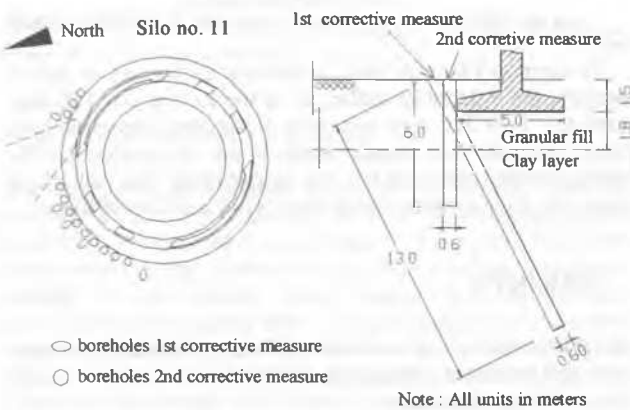

Figure 4. Direction and location of boreholes.

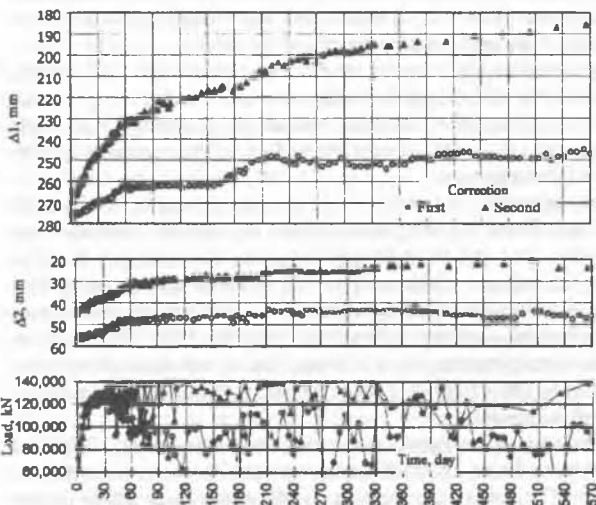

Figure 5. Performance of two corrective measures.

8 CONCLUSIONS

The silo discussed tilted excessively up to a dangerous state. Many alternatives for straightening were considered, but due to local configuration only one method was considered appropriate.

The soil extraction method was found to be a feasible method for straightening of tilted rigid structures. The method is very cost effective when compared to other alternatives, but does require thorough planning and monitoring.

It is believed that the extracted volume of soil is the main corrective factor – but not the only one. Other factors are size, directions, depth and closeness of the boreholes to each other; the levels of the most effective parts of the voids and how they affect the time/tilt relationship is not known. Slanted holes proved to be less effective than the vertical ones, because they were not or almost not inducing shear (or squeeze) in the upper clay layer.

There is a relationship between the volume of the extracted soil and the amount of displacement. The depth and the inclination of the boreholes is probably less critical within certain limits. The voids left by the vertical drilling caused horizontal soil movement, created squeeze in the upper soil layers and produced satisfactory vertical displacements.

The causes of the differential settlement were not removed and could even not be ameliorated. Therefore the tilt is probably not irreversible as was seen after the first stage of correction. The tilt time/factor is still a question mark.

ACKNOWLEDGEMENTS

The authors wish to thank Mr. Y. Israeli the general manager of the Nesher Plant for his continuous interests in the research. Also, thanks to Dr. Y. Amir for his participation in the early thoughts defining the most desirable method of decreasing the tilt. Also, the review of the manuscript by Mr. C. Redel and his many and useful comments are gratefully acknowledged.

REFERENCES

- Amir, Y. 1993. *Silo No. 11, Nesher Haifa. Geotechnical Report*. Ramat Hasharon: Amir Geotechnical Engineering Ltd.
- Amirsoleymani, T. 1991. Removing Soil Layers under Foundation to Rotate Buildings. *Proc. 9th Asian Regional Conference on Soil Mechanics and Foundation Engineering*: 201-204.
- Ansal, A.M. & Tuncan, M. 1989. Consolidation in clays due to cyclic stresses. *Proc. 12nd International Conference SMFE, Rio de Janeiro*. Vol 1: 3-6.
- Burland, J. 1995. Civil Engineering and the Leaning Tower of Pisa, *Civil Engineering – Siriele Ingegnierweise (South Africa)* 3(6): 9-12.
- Frydman, S. 2000. Shear strength of Israeli soils, *Israeli J. of Earth Science* 49: 55-64.
- Geffen, S. & Birnbaum, I. 1999. *Nesher, Haifa – the Dry Line site, Report on soil layer properties for foundation purposes*. Kfar Saba: S. Geffen Soils Engineering Ltd.
- Hofstetter, Van-Eck, & Shapira. 1996. Seismic Activity Along Fault Branches of the Dead Sea – Jordan Transform System: The Carmel – Tirza Fault System. *Tectonophysics* 267: 317-330.
- Jamiolkowski, M. & Viggiani, C. 1991. The Leaning Tower of Pisa – Present Situation. *Proc. X ECSMFE, Deformation of Soils and Displacements of Structures*. Vol IV: 1437-1445.
- Rahal, M.A. & Vuez, A.R. 1998. Analysis of Settlement and Pore Pressure Induced by Cyclic Loading of Silo. *Journal of Geotechnical and Geoenvironmental Engineering* 124(12): 1208-1210.
- Terracina, F. 1974. Sue Problem della Torre di Pisa, *Rassegna dei lavori pubblici Estrata dal*. Vol 10: 3-12.