

INTERNATIONAL SOCIETY FOR SOIL MECHANICS AND GEOTECHNICAL ENGINEERING



This paper was downloaded from the Online Library of the International Society for Soil Mechanics and Geotechnical Engineering (ISSMGE). The library is available here:

<https://www.issmge.org/publications/online-library>

This is an open-access database that archives thousands of papers published under the Auspices of the ISSMGE and maintained by the Innovation and Development Committee of ISSMGE.

D. Correlation between theoretical stress distribution in the soil and observed inequalities of settlements.

Conclusions: 1. The observed inequalities of settlement appear to be governed in the majority of cases by stress distribution in the soil derived from Boussinesq equation.

E. Effects of remoulding on clays.

Conclusions: 1. From results of compressive strength tests two types of clays have been found. The first unaffected by remoulding and the second decidedly affected by it. The influence of the remoulding on the bearing capacity of piles resting on the second clay is under study.

The papers No. B-4, C-1, D-1, E-1, E-2, F-1, Vol. I, give details about the investigations made.

Most of these investigations are in the initial stage and it will take some years before they are entirely completed. Results and preliminary deductions are nevertheless presented as tentative conclusions, subject to possible revision later, when more ample information will be accumulated.

No. A-2 REPORT ON TESTING APPARATUS, TECHNIQUE OF TESTING AND INVESTIGATIONS IN PROGRESS
Submitted by the Laboratory of Soil Mechanics, Delft

1. Name of institution, organization or firm supporting the laboratory; its location and year established.

"Laboratorium voor Grondmechanica" part of the foundation "Het Waterbouwkundig Laboratorium", Raam 61, Delft, Netherlands, established 15 February 1934, formerly a division of the Technical University; for scientific problems collaborating with the Technical University Delft, Department of Soil Mechanics (prof. ir. A. S. Keverling Buisman).

2. Name and title of person in charge of laboratory; number of persons on regular staff and average number of temporary employees or students engaged in research.

Managing Director ir. T. K. Huizinga; at this moment on staff:

5 engineers (for consulting and research work)	6 workmen (for field work)
4 assistants (for consulting and research work)	1 bookkeeper
2 draftsmen	2 workmen (construction and maintenance of app.)
1 engineer (for field work)	1 office boy
1 assistant (for field work)	

During the period of the existence of the laboratory 7 students of the technical college of civil Engineers at the "Technische Hoogeschool" Delft, worked on research problems.

3. Principal purpose for which laboratory is equipped (research, instruction or consulting service). Principally for consulting service, sustained by research work the latter serving as scientific studies for instruction in Soil Mechanics of the Technical University.

4. Description of equipment:

a. Total floor area, deducting office space. Humid room and constant temperature room; type of equipment for humidification and temperature control.

A plan of the laboratory is given in Fig. 1. The place and the room occupied by the apparatus are indicated by rectangles; the numbers referring to the legenda. Behind the indication the figure-numbers refer to the drawings in this same report. The humid-room is part of a cellar: it has no openings in the walls, besides the door. Humidification is caused by blankets, which are constantly kept saturated with water.

b. Apparatus for the classification of soils according to grain size distribution, grain shape, porosity, relative density, water content, air content, lime content, content of organic matter, specific gravity of mineral matter, Atterberg limit tests, consistency. Grain-size distribution.

Sieves. A set of sieves from 25.4 mm to 0.075 mm.

Atterberg method. A set of cylinders and beakers, Fig. 2.

Hydrometer method. A set of cylinders, an areometer, Fig. 3, a watertank for constant temperature, a movable needle-gauge for measuring difference in height between top of areometer and surface of fluid, Fig. 4, an electric drink-mixer.

Grain shape. A geological microscope

Water content, etc. An electric stove with thermostatic control. Small glass containers (for disturbed samples) A balance.

Organic matter-content and lime content. Boiling with H_2O_2 and HCl.

Lime content only. Apparatus according to Passon.

Specific gravity of mineral matter. A simple specific-gravity-meter.

Atterberg limit tests. Apparatus for lower liquid limit (acc. to Casagrande) Fig. 5.

Apparatus for lower plastic limit, Fig. 6. Simple apparatus for measuring lineal shrinkage (result of an investigation on different soils) Fig. 7.

Consistency. Measured by penetration-test, (cone-test) Fig. 10, 11, 27, 28.

c. Apparatus for shearing tests.

Normal shearing apparatus, Fig. 8,9. Litt. prof. ir. A. S. Buisman "de Ingenieur" 1928 No. 21. Cell-apparatus, Fig. 31, 32. Litt. prof. ir. A. S. Buisman "de Ingenieur" 1934 No. 26.

PLAN OF LABORATORY
GRUNDRISS DES LABORATORIUMS



FIG. 1

FIG. 8

SHEARING APPARATUS
SCHER APPARAT

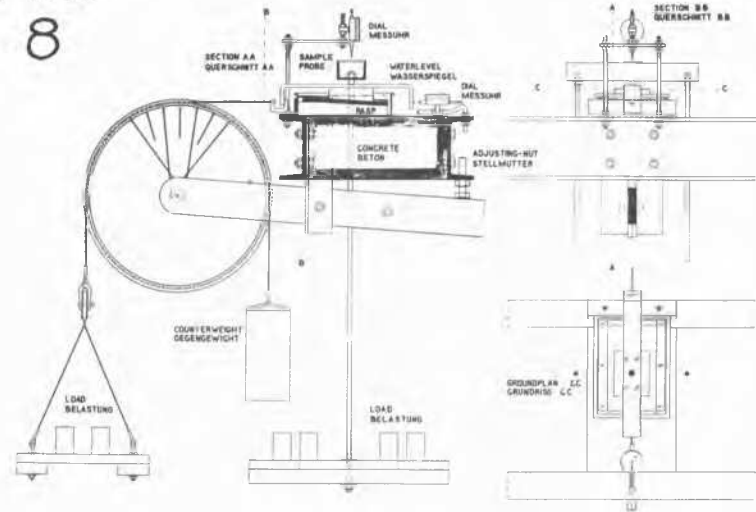

CONE TEST APPARATUS
KEGELPROBE APPARAT

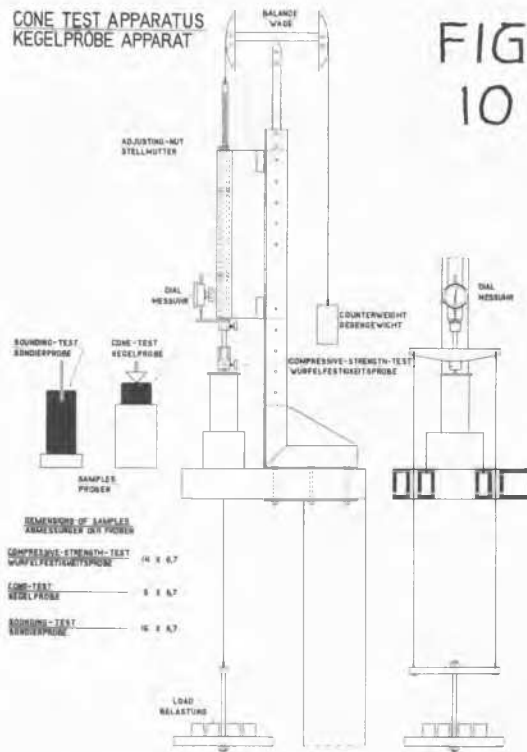

FIG. 10

CONSOLIDATION-APPARATUS
ODOMETER

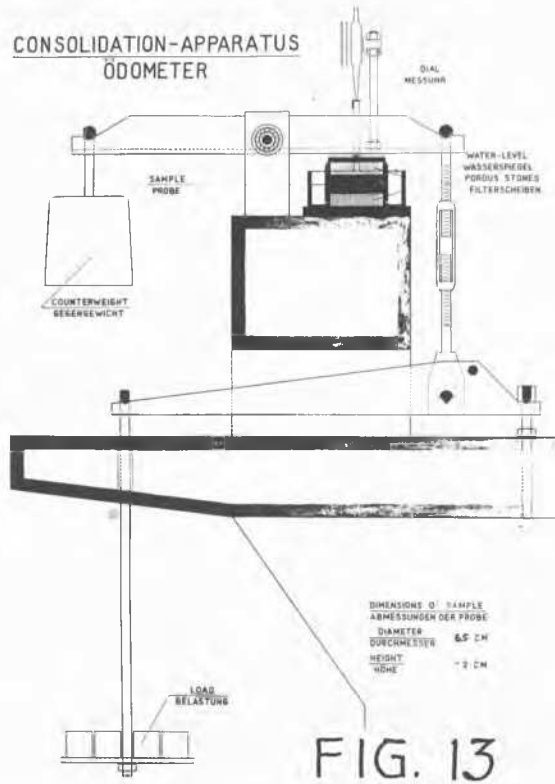

FIG. 13

CONSOLIDATION PERMEABILITY APPARATUS
ZUSAMMENDRÜCKUNG DURCHLÄSSIGKEITS-APPARAT

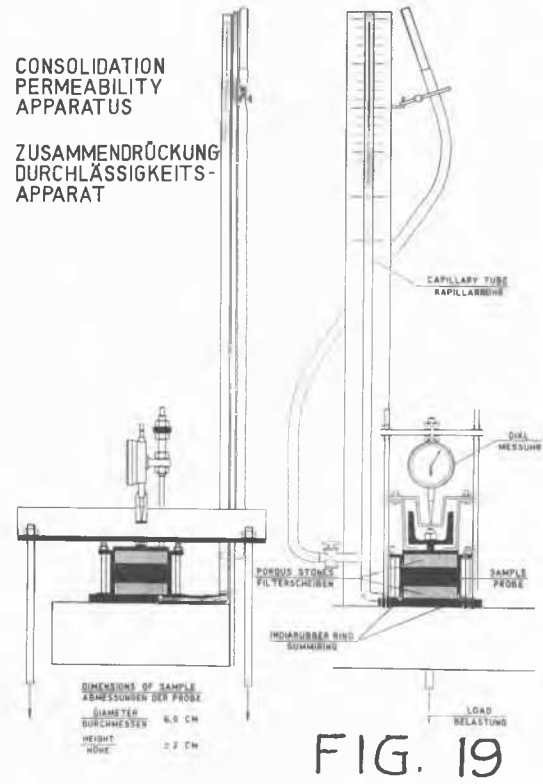
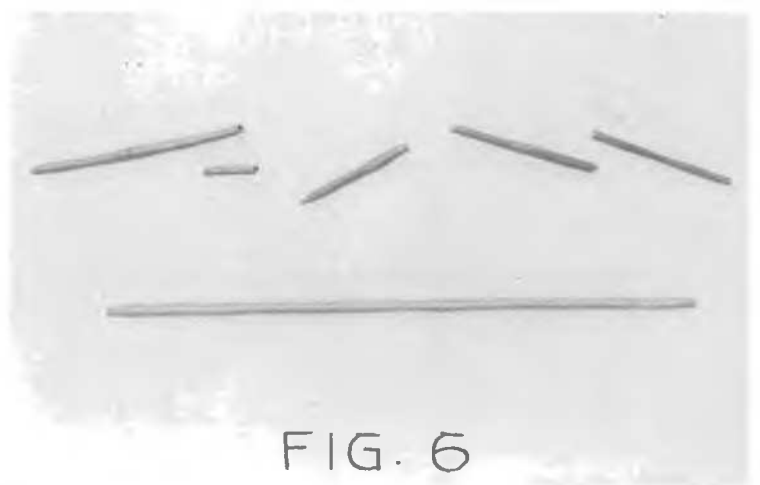
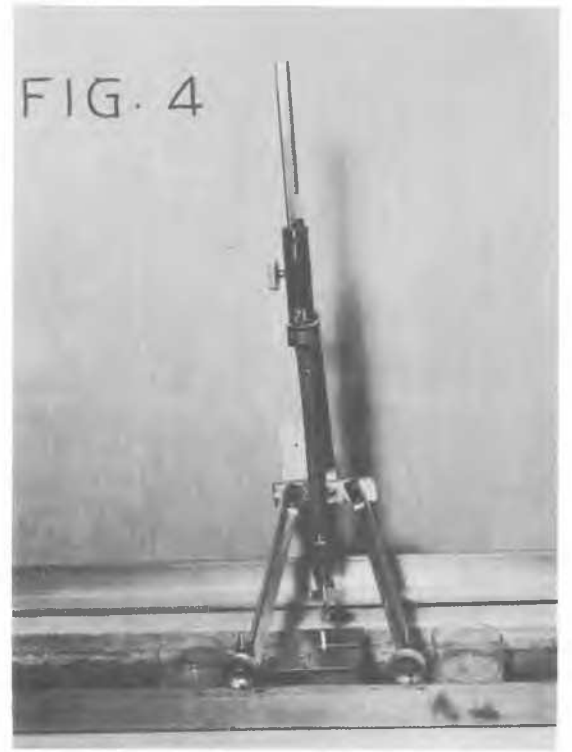

FIG. 19



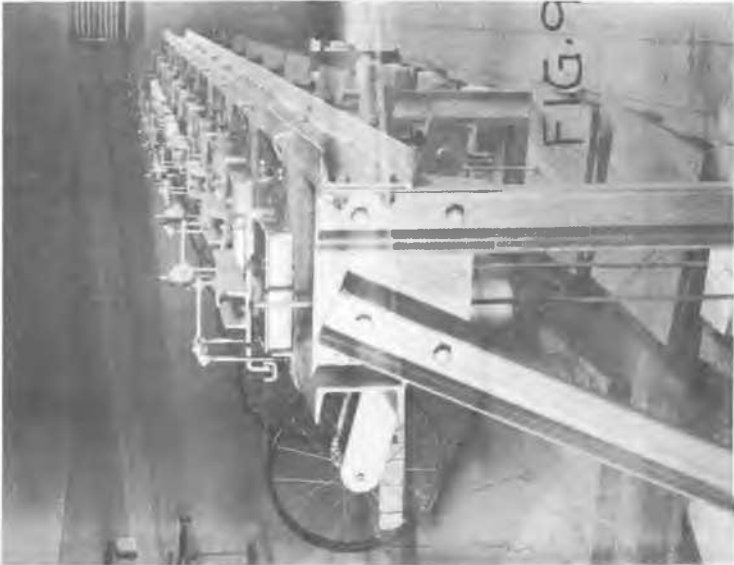

FIG. 9

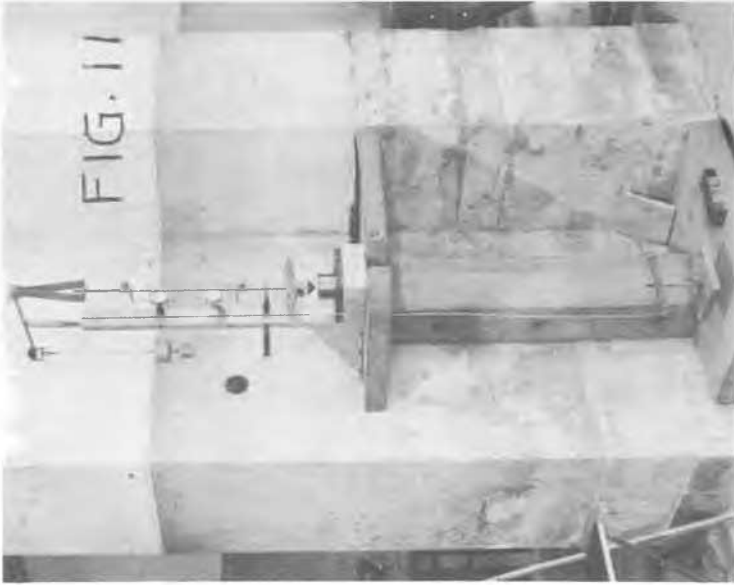

FIG. 11



FIG. 12

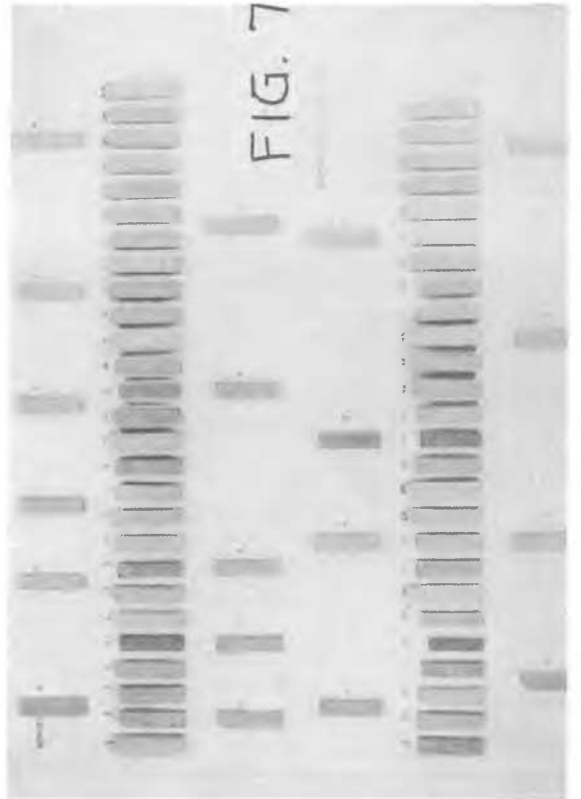

FIG. 7

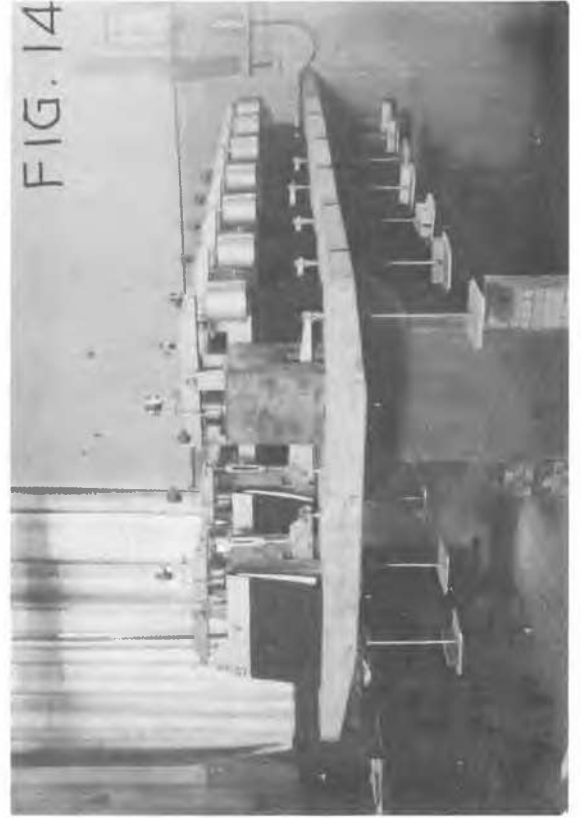

FIG. 14

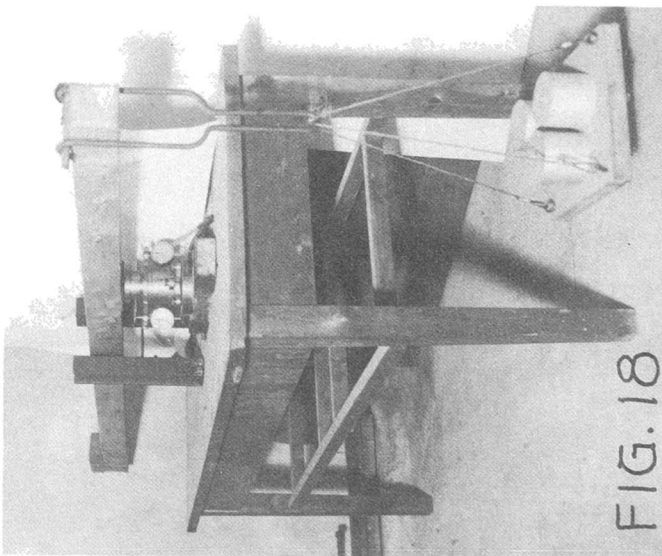
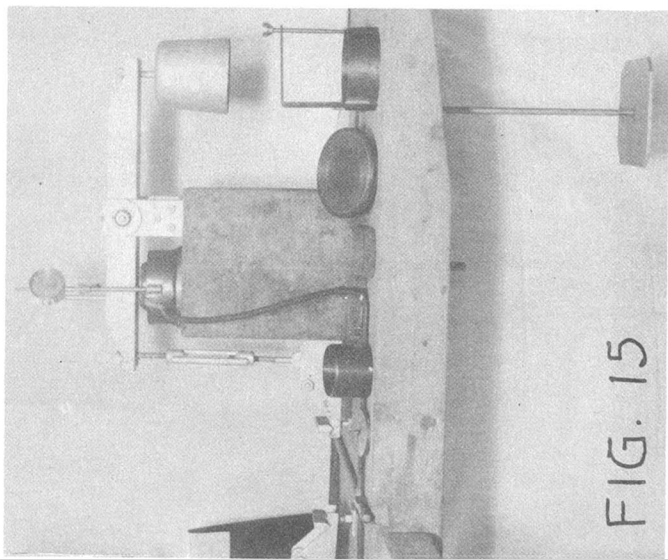
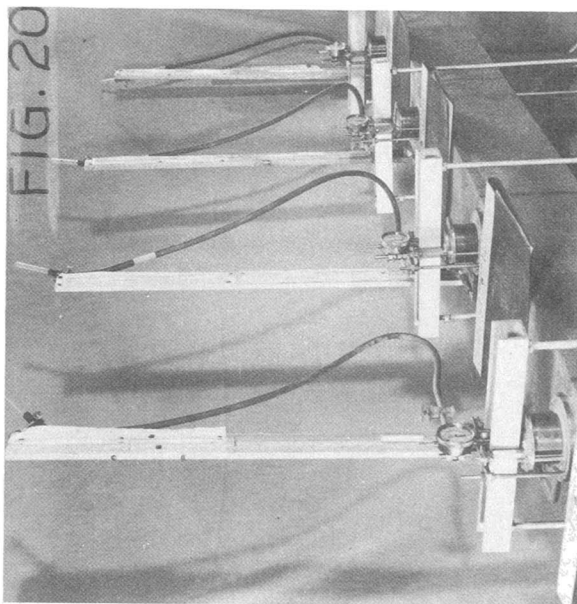
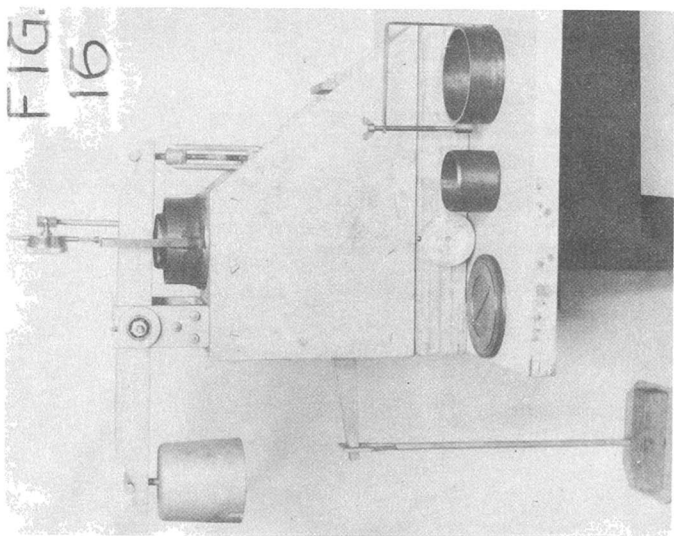
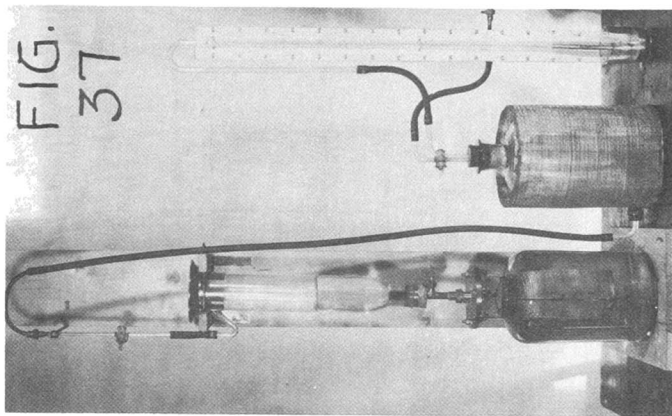
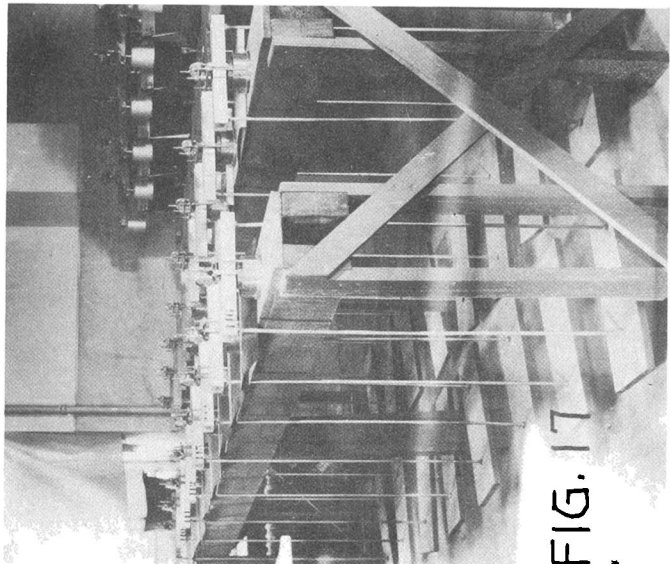

FIG. 21

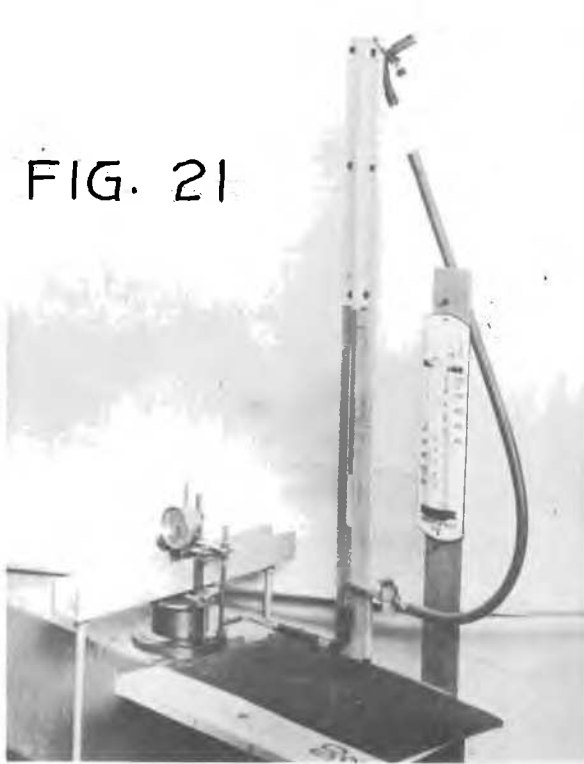

FIG. 23

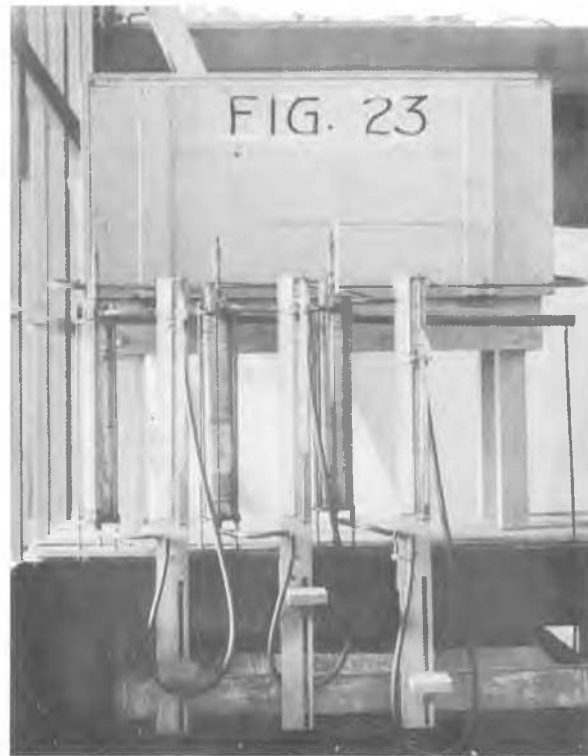

FIG. 26



FIG. 24



FIG. 28



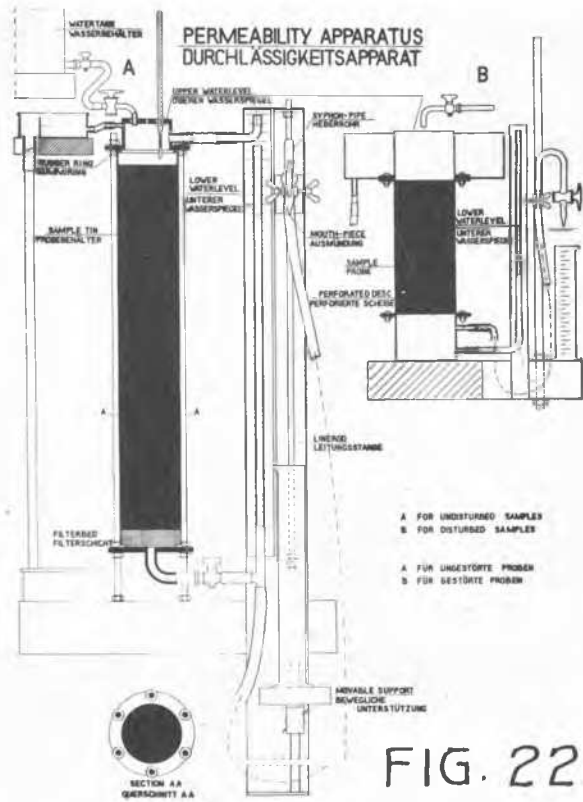

FIG. 22

CAPILLARY-METER
KAPILLARITÄTSMESSE

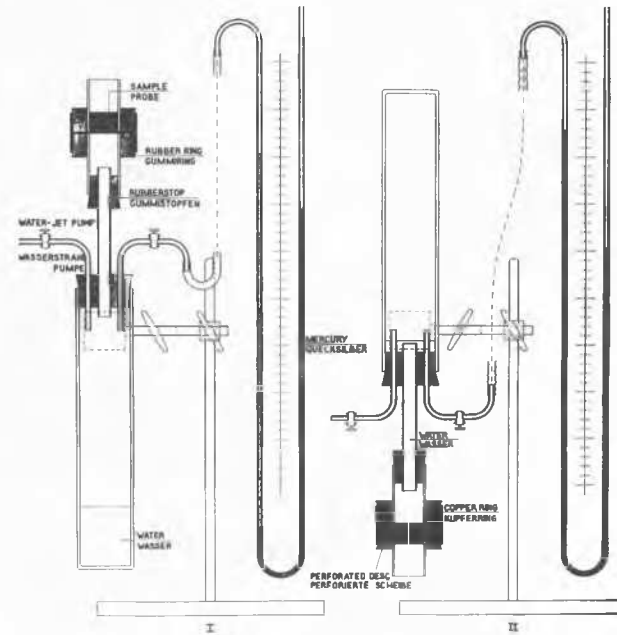

FIG. 25

CONE-TEST APPARATUS
WITH THE SAMPLE UNDER
SURFACE PRESSURE

KEGELPROBE APPARAT
MIT DER PROBE UNTER
FLÄCHENDRUCK

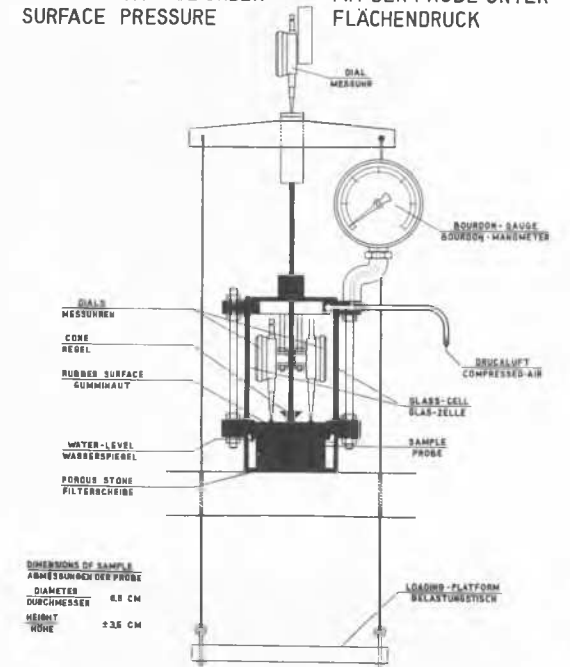
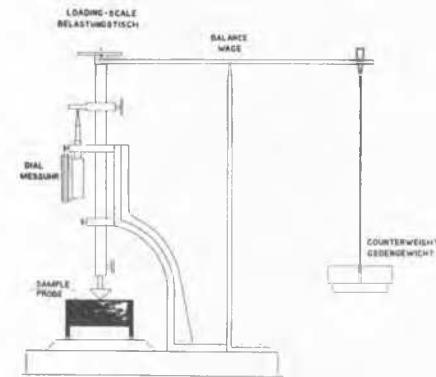

FIG. 29

CONE-TEST APPARATUS
KEGELPROBE APPARAT



DIMENSIONS OF SAMPLE
ABMESSUNGEN DER PROBE

DIAMETER	4.7 CM
HEIGHT	3 CM

FIG. 27

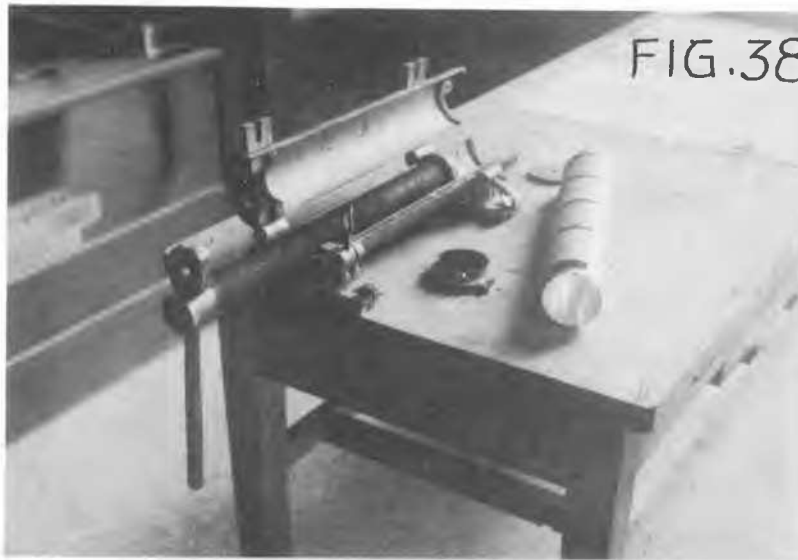

FIG. 38

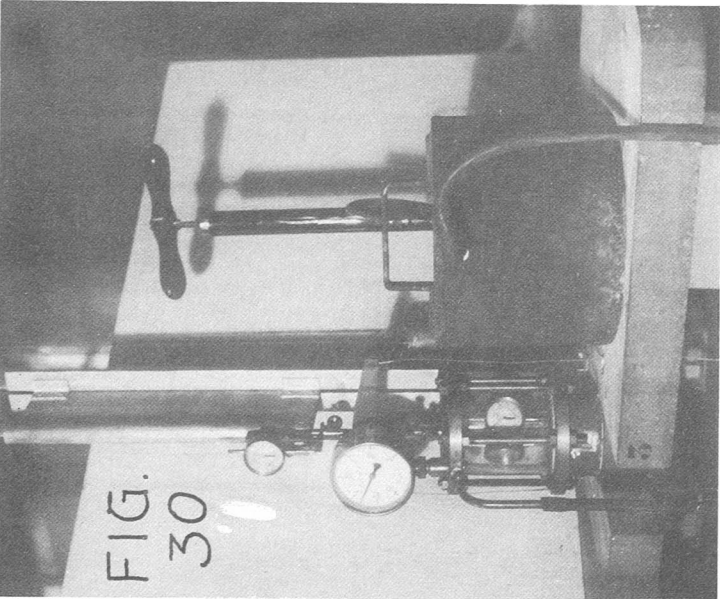

FIG.
30

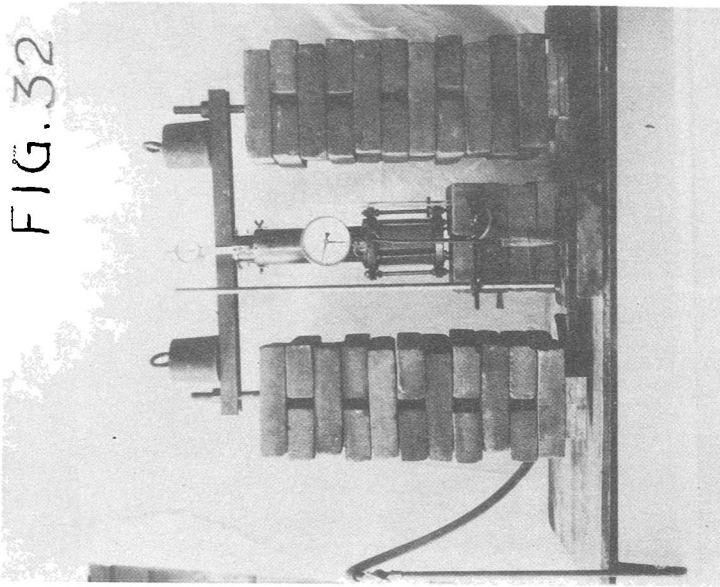

FIG. 32

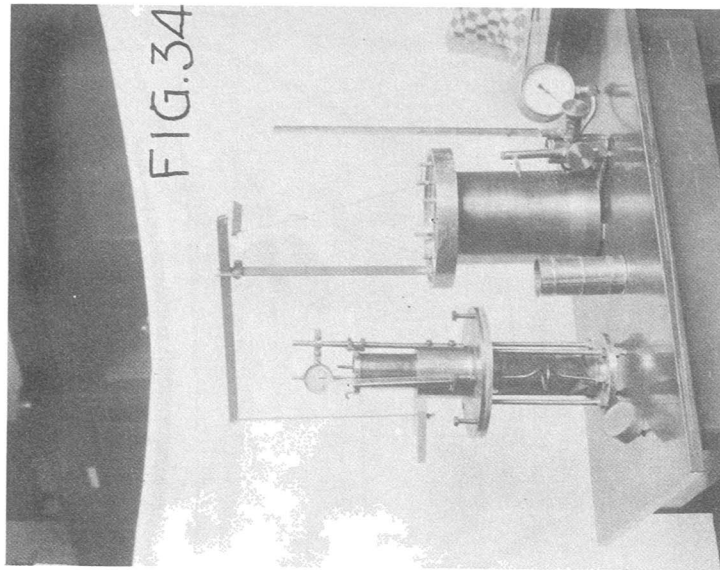

FIG. 34

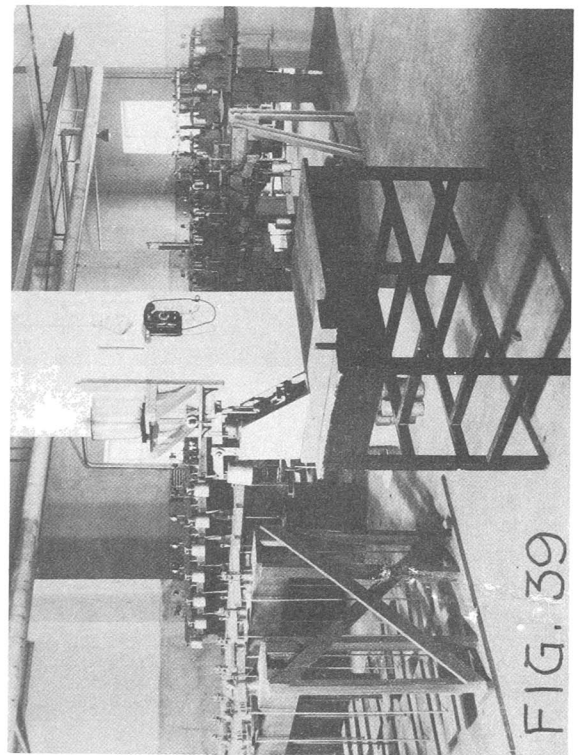

FIG. 39

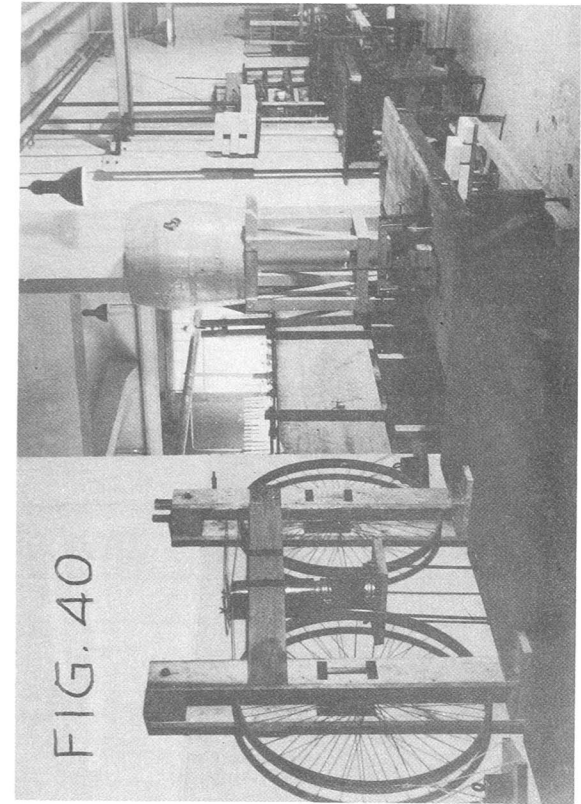

FIG. 40

FIG 35

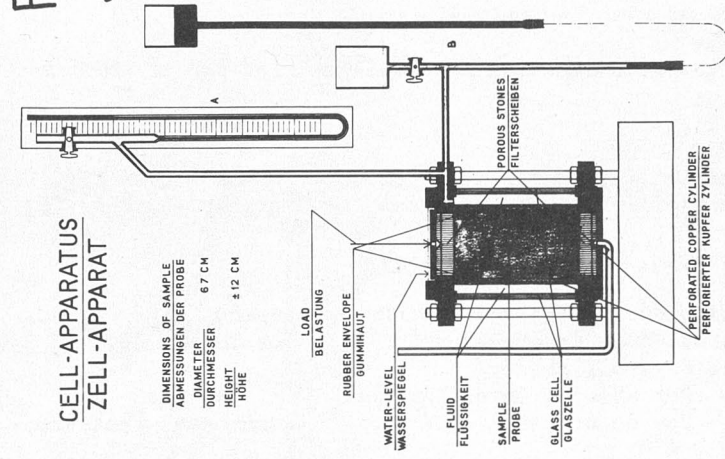

FIG 33

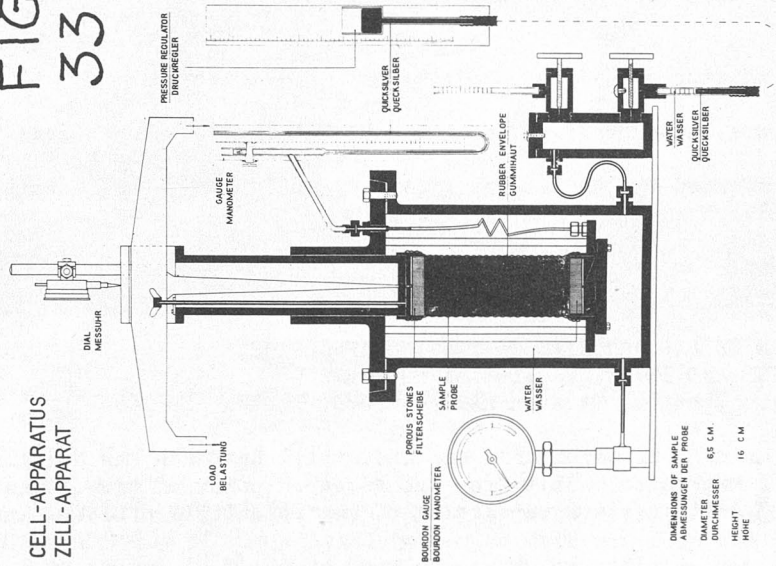

FIG 31

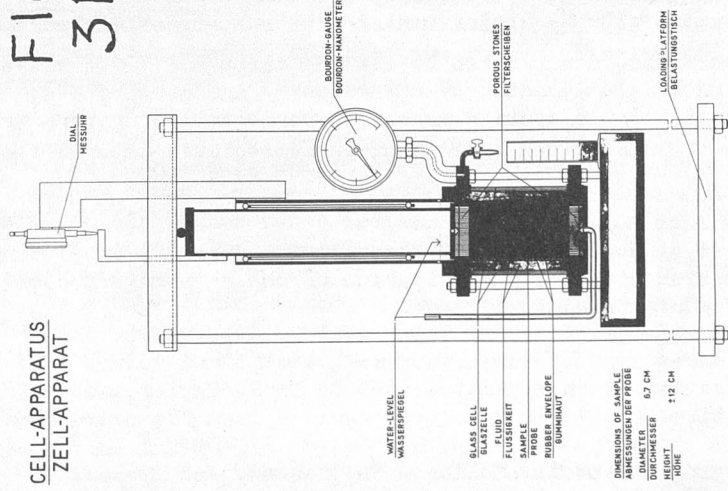

FIG. 36

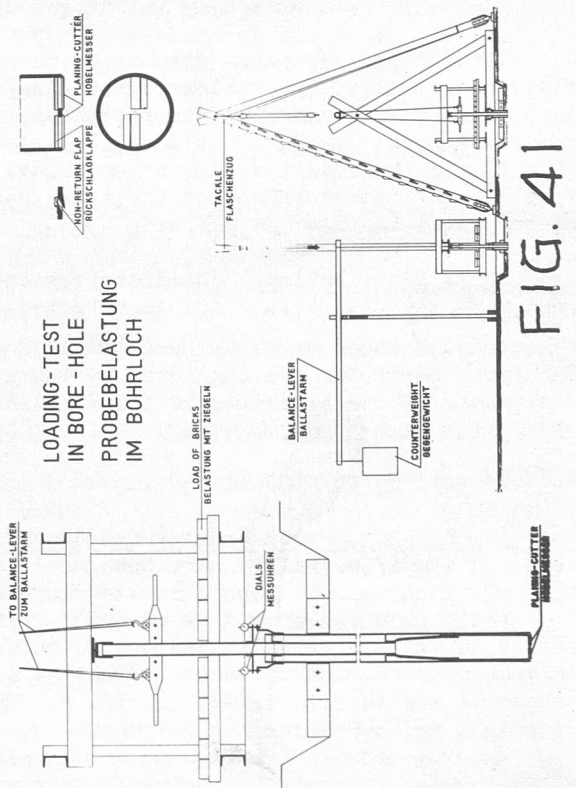
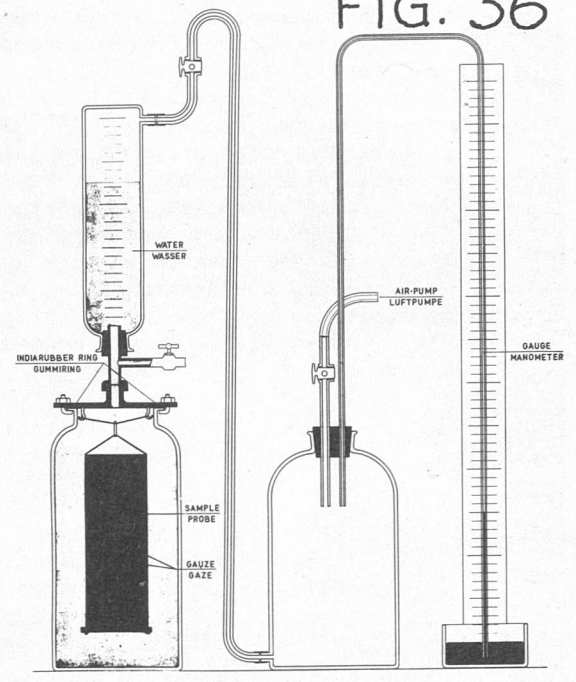

FIG. 41

- d. Apparatus for compressive strength tests.
Normal cone-test-apparatus. Fig. 10, 11, 12. (can be used for this purpose)
- e. Apparatus for consolidation tests.
Normal consolidation-apparatus. Fig. 13, 14, 15. Normal consolidation-apparatus (portable) Fig. 16. Simple consolidation apparatus, Fig. 17. Consolidation-apparatus (acc. to Terzaghi) Fig. 18.
Apparatus for consolidation tests combined with permeability tests.
normal apparatus. Fig. 19, 20, 21.
- f. Apparatus for permeability tests, for the determination of capillary rise and of maximum capillary pressure.
 - 1. for undisturbed samples. Fig. 23.
 - 2. for disturbed samples. Fig. 22.
for kneaded samples of low permeability consolidated under a certain load, Fig. 24.
 Apparatus for determination of maximum capillary pressure. (Acc. to Engelhardt). Fig. 25, 26.
- g. Apparatus for special investigations.
 - Cone test. Normal cone-test-apparatus, Fig. 10, 11.
Simple " " " Fig. 27, 28.
Apparatus for cone-tests on samples under surface pressure, Fig. 29, 30.
Litt. Prof. ir. A. S. Buisman "de Ingenieur", 1935, No. 14 and 18.
 - Cell-test. Normal cell-apparatus, Fig. 31, 32.
" " " for special investigations, Fig. 33, 34.
" " " for determination of neutral horizontal pressure, Fig. 35.
 - Apparatus for determination of gas-content of a sample, Fig. 36, 37.
 - Miscellaneous. Apparatus for pushing samples out of the tin, Fig. 38.
View on a corner of the laboratory, Fig. 39.
" " " set of used apparatus, Fig. 40.

5. Soil Testing Procedures:

- a. Tools and procedures for taking undisturbed samples. Dimensions of samples.
Refer to Paper No. B-1, Vol. I.
- b. Field testing methods. Loading tests, usual size of loaded area; loading tests in holes; vibration methods; etc.
A sketch of a loading test, as performed by the laboratory, in a bore hole at great depth, on a sandlayer is given in Fig. 41.

No. A-3

REPORTS FROM SOIL MECHANICS LABORATORIES ON TESTING APPARATUS, TECHNIQUE OF TESTING AND INVESTIGATIONS IN PROGRESS Submitted by Building Research Station, Garston near Watford, Herts. England

The Building Research Station of the Department of Scientific and Industrial Research has a small section investigating problems concerning soil mechanics mainly from the research point of view. The investigation was commenced in September, 1933, with a staff consisting of two scientific officers and two assistants.

Simple physical tests of an empirical nature, similar to those employed by the U.S. Bureau of Public Roads, are carried out for the purposes of soil classification. The apparatus and methods may be briefly summarized as follows.

Grain Size Distribution. The distribution of grain size is investigated by a combined sieve and sedimentation method. Dispersion is effected by treatment with $\frac{N}{100}$ Sodium Oxalate and rubber pestling after a method described by P. Kamerman (1). The coarser sand is separated by sieving through a '200' sieve. The finer particles are estimated by the pipette method, originated by Andreason (2) and developed by Robinson (3). The apparatus is illustrated in Fig. 1. Soils containing calcium carbonate or gypsum are pretreated with $\frac{N}{5}$ HCl, followed by washing. When organic matter is present in appreciable amounts the soil is pretreated with 6% H_2O_2 .

Relative Density, Water Content and Specific Gravity. Measurements of the relative density, water content and specific gravity have been made in connection with the investigation of the shrinkage properties of cohesive soils, both in the disturbed and undisturbed conditions.

Small rectangular prisms of soil of size approximately 2 in x 1 in x 1 in are used. The sample is weighed and then its volume is rapidly determined by comparison with a standard volume in a mercury displacement volumeter. This is a modification of an apparatus used by Puri, Taylor and Ashgar (4) and is illustrated in Fig. 2. The relative density is of course derived from the measurements of weight and corresponding volumes.

The volumetric shrinkage of the sample on drying is readily followed in this way and typical results showing the relation between water content and volume are illustrated in Fig. 3.