

# INTERNATIONAL SOCIETY FOR SOIL MECHANICS AND GEOTECHNICAL ENGINEERING



*This paper was downloaded from the Online Library of the International Society for Soil Mechanics and Geotechnical Engineering (ISSMGE). The library is available here:*

<https://www.issmge.org/publications/online-library>

*This is an open-access database that archives thousands of papers published under the Auspices of the ISSMGE and maintained by the Innovation and Development Committee of ISSMGE.*

# Experience with gel-push sampling in New Zealand

M.E. Stringer & M. Cubrinovski

*Department of Civil and Natural Resources Engineering, University of Canterbury, New Zealand*

I. Haycock

*McMillan Drilling, New Zealand*

**ABSTRACT:** The gel-push sampling technique was developed to try to provide an economic technique capable of obtaining high quality specimens of silty sands and sands. This paper describes two of the gel-push samplers which are now commercially available and describes their performance on recent projects carried out on soils in New Zealand with reference to field measurements of shear wave velocity.

## 1 INTRODUCTION

High quality soil sampling is well established, and many tools and techniques have been developed over the years to obtain samples of different types of soils. Of particular relevance to the earthquake engineering community is the ability to obtain undisturbed samples of sands and silty sands, so that their behaviour during the cyclic loading of an earthquake can be better understood. Yoshimi et al (1994) showed that it is very difficult to obtain high quality specimens of these soils using downhole samplers. To date, freeze sampling remains the “gold standard” for obtaining sand samples, though the associated costs make it unfeasible for most projects.

## 2 GEL-PUSH SAMPLING

The gel-push sampling methodology was developed by Kiso-Jiban Consultants (Japan) with the aim of retrieving undisturbed specimens of silty and clean sands at reasonable cost. The technique has been used by a number of researchers in locations around the world including Japan, Taiwan, Poland, Bangladesh and New Zealand (e.g. Lee et al. 2012, Taylor et al. 2012, Jamiolkowski 2014).

It is assumed that the main source of disturbance associated with conventional downhole tools is due to friction which is mobilised on the sides of the soil sample as it enters the core-liner barrel. Gel-push sampling removes this friction by coating the outer surface of the soil (as it enters the sampler) with a low-friction polymer gel.

Gel-push sampling is typically carried out with one of three types of sampler: GP-S, GP-Tr and GP-D. These three samplers are conceptually similar to

existing techniques, with some modification to allow the delivery of gel to the base of the sampler.

It is important to note that gel-push sampling is still developing, and small changes to the samplers are occasionally made by the designers to address specific issues which are reported by end users.

While all three tools are available in New Zealand, experience to date is limited to the GP-S and GP-Tr samplers. A brief description of these samplers is given in the following section, while more details concerning the samplers and field procedures are given in Stringer et al. (2015b).

### 2.1 GP-S Sampling

The GP-S sampler is similar to the improved Osterberg sampler (Osterberg 1973), comprising three barrels, one fixed and two travelling pistons, as shown in Figure 1 **Error! Reference source not found.** Samples are captured inside a PVC core-liner barrel, with approximate inner/outer diameters of 71/76 mm and 99 cm length. Holes near the top of the core-liner barrel allow the polymer gel to flow during sampling. Prior to inserting the core-liner barrel into the sampler, the middle barrel is filled with polymer gel. This ensures gel coats both sides of the core-liner barrel when it is inserted.

The fixed piston of the sampler is fitted to the end of the fixed piston shaft, and features an internal mechanism to enable the core-catcher activation process. Finally, a cutting shoe (with an inner diameter slightly smaller than the core-liner barrel) is attached to the bottom end of the middle barrel.

During sampling, clean water is pumped into the sampler through the drilling rods. The hydraulic pressure acting on the upper travelling piston advances the middle and core-liner barrels. The reduction in the

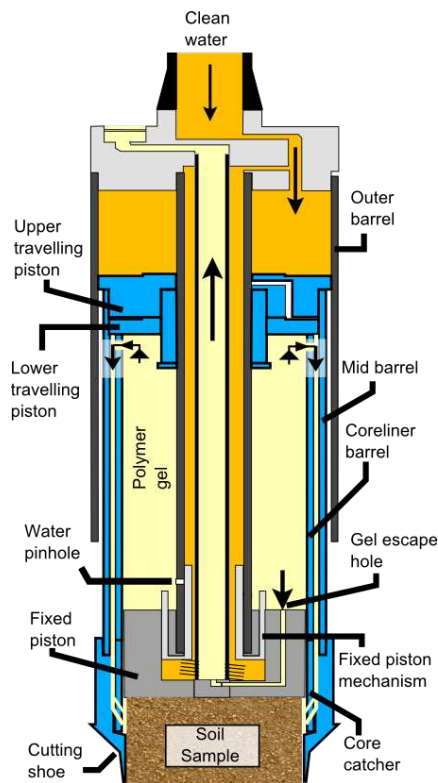

Figure 1: Schematic of GP-S type sampler

volume between the travelling and fixed pistons forces some of the polymer gel to pass through the holes in the top of the core-liner barrel and travel down the annulus between the inner and middle barrel. The gel passes through the fins of the core catcher, and coats the outer edge of the soil sample as it is captured in the sampler. The remaining polymer gel is vented through “gel-escape holes” in the fixed piston, travelling up the central shaft of the sampler and exiting into the borehole.

When the travelling pistons reach the fixed piston, the internal fixed piston mechanism is activated and hydraulic pressure is supplied between the upper and lower travelling pistons. At this point, the lower travelling piston acts on the core-liner barrel only, which advances a small distance to partially close the fins of the core catcher. In this way, the soil sample is prevented from dropping out of the sampler, and the tool can be carefully retrieved from the borehole and laid out horizontally to enable the soil sample to be retrieved. Complete recovery with this sampler results in 92cm of soil, not including any material retained in the core catcher. Typically, GP-S sampling is completed in a period of 1-2 minutes.

## 2.2 GP-TR Sampling

The GP-TR sampler is a rotary triple tube device; a sketch of key components is shown in Figure 2. **Error! Reference source not found.** Drilling mud is pumped through a rotating reaming shoe to help remove soil in the bottom of the borehole, and allow the sampler to advance. Protruding slightly ahead of the

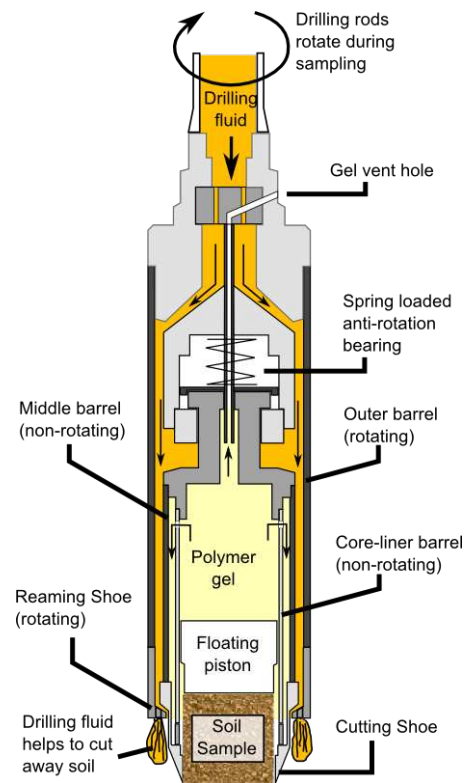

Figure 2: Schematic of GP-TR type sampler

reaming shoe is a spring-loaded non-rotating cutting shoe. Soil passing through the cutting shoe is captured within a PVC core-liner barrel (outer/inner diameter = 89/83.5 mm). The floating piston moves upwards on the top of the captured soil column, and forces polymer gel to travel down the annulus between core-liner barrel and middle barrel, exiting above the cutting shoe and coating the soil sample. Excess gel is vented into the main borehole. Full recovery with this sampler is approximately 100 cm. Ideal sampling with the GP-TR is slow and steady, taking at least 10 minutes to advance the tool 100 cm.

## 2.3 Choice of Sampler

While the GP-S sampler appears a more complex tool, the physical operation of the device is much less demanding on the drilling crew than the GP-TR (the GP-TR requires manual control of the rate of advance, the flow rate of drilling mud and the rate of rotation), and as such is likely to be easier to operate to its “full” potential. Due to the thin-walled sections within the GP-S sampler, the hydraulic pressure which can be applied to the sampler is limited to 7 MPa, on the advice of the manufacturer. The ratio of piston driving area to the area of the cutting shoe shoulder is approximately 2.2, implying an upper limit of 15 MPa. However, allowing for any leaks in the drill rods, pressure required to drive the gel through the restricted passages and friction within the device, the authors recommend that an upper limit on

cone tip resistance ( $q_c$ ) of 5 MPa be applied when using the GP-S sampler and switching to the GP-TR sampler above this level.

### 3 ASSESSING “SPECIMEN QUALITY”

One of the most important things to consider when carrying out advanced laboratory tests (such as triaxial tests) on field samples is how well the in-situ density and fabric (structure) of the soil has been preserved. When evaluating the performance of the gel-push samplers in different soil types, the authors have chosen to use a number of different criteria. First, whether there is any visual disturbance to the soil specimen, or if anything has occurred during the sampling, transportation and preparation which is likely to have caused severe disturbance to the specimen. Where the specimens appear in good condition, it is desirable to compare measurable in-situ properties with values measured in the laboratory. In this paper, measurements of shear wave velocity have been used as a basis for this comparison.

Shear wave velocity ( $V_s$ ) is related to small strain shear modulus ( $G_0$ ) and density ( $\rho$ ) by Equation 1:

$$G_0 = \rho V_s^2 \quad (1)$$

The shear modulus reduces significantly on the application of even modest shear strains, hence offers a good insight into any disturbance which might affect a specimen. Soil stiffness increases with stress level in the directions both parallel and normal to the wave propagation. Hence differences between the stress level in the field and the laboratory (e.g.  $K_0$  conditions in the field vs isotropic in the lab) must be accounted for. To account for differences in stress levels, the shear wave velocity measurements are normalised to a stress level of 1 atmosphere ( $V_{s1}$ ), using Equation 2, where  $P_a$  is atmospheric pressure and  $p'$  is the mean effective stress. Given the limited number of undisturbed specimens, it was necessary to assume that the principal stress ratio doesn't affect  $G_0$  or  $V_s$  provided  $p'$  is constant.

$$V_{s1} = V_s \left( \frac{P_a}{p'} \right)^{0.25} = V_s \left( \frac{3P_a}{\sigma_v' + 2\sigma_h'} \right)^{0.25} \quad (2)$$

#### 3.1 Measurement of $V_s$ in the field

As part of the projects described in Sections 4.1 and 5, a number of field-based tests were carried out at each research site. Among these were direct-push cross-hole measurements (described by Wotherspoon et al. 2015) of  $V_s$  and  $V_p$ , carried out every 20cm. The resulting  $V_s$  profile (vertically orientated, horizontally propagating waves) has been used to evaluate the sampling performance in this paper.

#### 3.2 Measurement of $V_s$ on undisturbed specimens

After sampling, soil samples were carefully transported back to the laboratory (in a vertical orientation) where they were extruded from their core-liner barrels. During extrusion, the samples were cut into (approximately) 15 cm lengths before being wrapped in cling film until they are tested.

The polymer gel which is used during sampling tends to penetrate a couple of millimetres into the specimen. Hence extruded specimens are carefully trimmed using a soil lathe prior to carrying out triaxial testing; the final specimen is 50 mm in diameter and 100 mm tall. Small slots are cut into the top & bottom of the specimen with a razor blade to facilitate the insertion of the bender elements when the specimen is mounted on the triaxial platens.

Specimens are saturated (typically by percolating  $CO_2$  and then deaired water through the specimen). The back-pressure is then raised until the B-Value is at least 0.97. Saturated specimens are isotropically consolidated to a mean stress equal to 1.1 times the estimated in-situ vertical effective stress to ensure that specimens are normally consolidated.

Once consolidated, the shear wave velocity is estimated using bender elements excited at a number of discrete frequencies between 4 kHz and 8 kHz. The arrival time of the shear wave is estimated as the point just prior to the first major peak, where the receiver signal denotes that the bender element is beginning to deflect in the direction associated with the incoming wave. Travel distance is taken as the distance between the tips of the bender elements.

### 4 EXPERIENCE WITH THE GP-S SAMPLER

#### 4.1 Silty Soils and Silts

Undisturbed sampling was carried out with the GP-S sampler in the suburban park of Gainsborough Reserve in Christchurch, New Zealand. A total of 10 samples were taken in three different boreholes at depths between 0.4 m and 9 m below the ground surface. The soil profile at this site consists of alternating layers of silts and sandy silts. The upper 6 m of CPT data is shown in Figure 3 **Error! Reference source not found.** CPT results to a depth of 10 m indicated that  $q_c$  values in the deeper silty sand layers increased with depth, reaching approximately 7 MPa in the deepest target layer for sampling. The top of the sampling intervals, average CPT values and the recovery of each sample are listed in Table 1.

The poor recovery of samples S2-GP1-1U and 3U arose from issues with the core catcher; In the case of the first sample, the sampling was prematurely stopped such that the core catcher was not activated. As a result, the recovered sample dropped out of the sampler when it was being recovered. In the second

Table 1: Samples recovered at Gainsborough Reserve

Sample	Depth (m)	$q_c$ (MPa)	$I_c$	Recovery (%)
S2-GP1-1U	0.4	1.3	2.7	0
S2-GP1-2U	2.5	2.2	2.2	78
S2-GP1-3U	3.6	0.4	3.2	27
S2-GP1-4U	5.0	4	2.0	90
S2-GP1-5U	6.5	1.3	2.0/3.0	53
S2-GP1-6U	8.0	6	1.9	60
S2-GP2-1U	0.8	0.8	2.9	66
S2-GP2-2U	3.6	0.4	3.2	53
S2-GP3-1U	0.5	1.3	2.7	89
S2-GP3-2U	3.6	0.4	3.2	96

case, the core catcher was partially activated, but the fins of the core catcher locked together during sampling. When the sampler was recovered to the surface, portions of the soil sample were dropping out of the sampler; It appeared that despite the partial closure of the catcher, the silty material experienced large axial extension, and significant radial contraction, such that it was able to pass through the partially activated core catcher.

On extrusion, S2-GP1-5U, 6U and S2-GP2-1U were found to be severely cracked, with the soil sample clearly split into several pieces during sampling. Sample S2-GP2-2U was found to contain large amounts of wood.

The GP-S sampler is hydraulically advanced using clean water. Hence the drilling rods are disconnected from the rig prior to sampling. Vertical reaction loads during the initial sampling attempts at Gainsborough Reserve were mobilised using the hydraulic break-out arms of the drilling rig. While this arrangement is adequate for soils with very low penetration resistance, it was observed that the arms would lift slightly during sampling attempts. In the cases of S2-GP1-5U

and 6U, noises were heard during sampling, which are now known to have been the drilling rods slipping through the clamps. These mechanisms have severe consequences for the sampling (especially the latter), since upward movement of the drilling rods (and therefore the fixed piston) can create tensile loads on the top of the specimen. If it happens slowly, and at the start of sampling (i.e. mechanism 1), it is possible that polymer gel can flow into the space between the top of the soil sample and the fixed piston. However, if the movement is rapid and occurs while sampling is underway, then a large vacuum will be created at the top of the specimen. This is assumed to be the cause of the breaks in the specimens previously mentioned.

The remaining 4 samples appeared much better when extruded, though several horizontal cracks up to 1 inch in length were observed on the outer edge of sample S2-GP3-1U, and some vertically orientated cuts were observed running the entire length of S2-GP3-2U (this sample was taken at the same depth as S2-GP2-2U and the cuts are assumed to be caused by a twig caught on the leading edge of the sampler). These four samples were deemed of sufficient quality to test in the cyclic triaxial device. Figure 4 shows an example of a specimen which was tested from sample S2-GP1-2U. The sample moved freely within the core-liner barrel and the exterior of the extruded sample appears free of defects and when the specimen was trimmed in the soil lathe, it was apparent that the finely interlayered soil structure was preserved during sampling.

The laboratory shear wave velocities (corrected for stress level) of the specimens taken from the four samples which were tested are shown in Figure 3 with black squares. Two profiles of shear wave velocity were carried out approximately 3m from the sampling boreholes and are represented by lines with cross markers. The data in this figure appears to suggest that the shear stiffness of the specimens is close to that in the field for the specimens taken between 2.5 and 5.8m below the

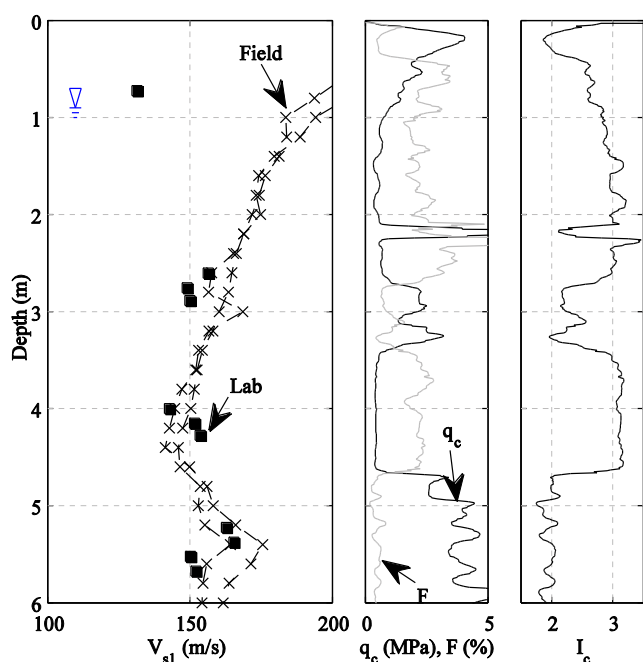

Figure 3: Comparison of lab and field shear wave velocities for samples obtained at Gainsborough Reserve



(a) As extruded

(b) After trimming

Figure 4: Specimen S2-GP1-2U-C

ground surface. These specimens came from layers comprising silty sands and silt.

By contrast, the shear wave velocity from the shallowest silty sand layer (S2-GP3-1U) falls far beneath the value measured in-situ. This specimen was above the water table, and as previously described, this specimen had a number of cracks on its exterior.

#### 4.2 Micaceous Silts

Gel-push sampling was attempted on soft micaceous silt, at a site in the South of New Zealand using the GP-S sampler. A total of 4 soil samples were obtained using the GP-S sampler, and 3 using a conventional push tube sampler (1m long). The soil sampling intervals were selected from a CPT log and had  $I_c$  values between 2 and 2.6, and  $q_c$  values between 2 and 5 MPa. The recoveries from the gel-push sampling ranged between 65 % and 87 % of the theoretical maximum.

Despite good recovery in some tubes, the extrusion of these samples was very difficult. When load was applied at the base of the soil sample, water would be squeezed out, and it was not possible to push the soil out of the tube. As a result, the plastic core liner barrels were cut open by hand. When opened, the soil occupied the full diameter of the core-liner barrel, and with the exception of a few small areas, no polymer gel was present on the soil surface. The conventional push tubes were cut into short sections of 15cm in length before de-bonding the soil from the tube. During the initial cutting it was observed that these soils swelled rapidly and by a large amount. Similar behaviour in the gel-push samples would have squeezed the gel out of the annular space between the soil and core-liner barrel. Given the relatively fine grained nature of these soils, it is unlikely that the gel would have been sucked into the soils. While it is unknown when the gel was squeezed out of the space between sample and core barrel, it is clear that the beneficial effects were lost by the time it came to extruding the samples. Therefore, in the case of these special soils, the friction associated with conventional sampling methods would also affect gel-push sampling. Depending how rapidly the swelling occurs it may be possible to obtain good results if the samples are extruded from the tubes almost immediately after sampling, though this approach has not been attempted.

#### 5 EXPERIENCE WITH GP-TR SAMPLER IN CLEAN SAND

Undisturbed sampling with the GP-TR sampler was attempted in the clean sands which are found in the Eastern Suburb of Bexley in Christchurch. The testing site (18-20 Wairoa Street) has been included in

many research projects (including the “Ground Improvement Trials”) and as such a large amount of characterisation data was available. A selection of CPT data from the site is shown in Figure 5 and indicates some of the soil variability in this area of Christchurch. A large number of samples were obtained using both GP-S and GP-TR samplers, but a number of issues not related to the sampling were encountered. The discussion in this section therefore focusses on three samples obtained using the GP-TR sampler between 3.5 and 6.5m below the ground surface. These samples represent the best performance which has been obtained in clean sand with this sampler in New Zealand to date. It should be noted that the soils being sampled were clean sands which were likely to be uncemented. These are therefore some of the most challenging soils to attempt undisturbed sampling.

In each case, the soil sample was obtained with the drill rods rotating at approximately 80rpm, and advancing 1m over a period of 20minutes. The advance of the sampler was controlled manually and aimed to maintain a very slow, but continuous advance. Conventional mud was pumped through the drill rods throughout the sampling, with the rate being controlled by the driller who attempted to keep the flow rate low enough to prevent washing out the bottom of the hole, but high enough to provide some cutting action (via the fluid jets).

Samples were drained on-site prior to transportation back to the laboratory (in a vertical orientation). It was observed on-site that the soil specimens were very difficult to move within the tubes.

When the samples were extruded, they appeared in a good condition visually, though the sides of the

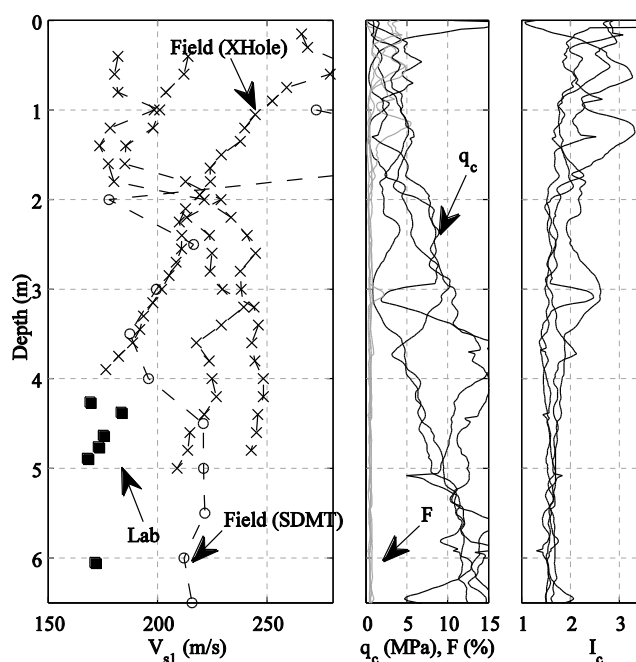

Figure 5: Comparison of lab and field shear wave velocities for samples obtained at Bexley

specimens were not coated in gel. During the trimming of the specimens, it was observed that the polymer gel had penetrated deep inside the specimen.

In addition to the cross-hole  $V_s$  measurements, a downhole  $V_s$  profile was available from a seismic dilatometer test. This profile is shown in Figure 5 with circular markers, while the cross-hole data is shown with crosses. There is some apparent scatter in the field measurements of  $V_{s1}$ . However, the laboratory measurements of  $V_{s1}$  are significantly lower than the field measurements. The observation that the samples did not slide easily in the tube implies that some radial straining has occurred during the sampling (or when the samples are retrieved from the tool). It is thought that the coarse grained nature of these soils prevented the soils from maintaining any effective stresses once they were captured within the sample barrel, with the polymer gel solution able to flow into the sample, rather than providing a coating on the exterior. Any small vibrations, or even self weight of the sample may have led to the samples straining outwards against the walls of the core liner barrel. If this occurred, the samples would be expected to rub against the side of the core-liner barrel, generating increasing amounts of sidewall friction. Fonseca & Coutinho (2008) pointed out that soil disturbance can occur in rotary triple tube sampling as a result of incorrect combinations of drilling parameters (i.e. fluid flow rate, penetration rate etc). It is therefore also possible that the disturbance of these samples was caused by inappropriate drilling settings.

## 6 SUMMARY AND FINAL REMARKS

The gel-push sampling methodology remains an emerging technique. The trials conducted in New Zealand have shown that there will be a range of soils for which these samplers can recover high quality soil specimens. The procedures for sampling are still evolving and it is expected that as more experience is gained, refinements will be made to the way that sampling is carried out which will improve the performance of the gel-push samplers.

The success of gel-push sampling depends as much on the treatment of the samples once the tool is recovered from the ground as the actual process of sampling. Ensuring that the drilling crews understand that the samplers must be handled with exceptional care while the core-liner barrels are recovered is fundamental to the success of the sampling.

In the trials, the GP-S sampler was successful in recovering samples of silts and silty sands with low values of cone penetration resistance (<5MPa). Key issues which require specific attention with this sampler include: ensuring that sufficient vertical reaction loads can be mobilised to prevent the drilling rods moving upwards during sampling; that the pressure

and volume of water pumped during sampling is carefully monitored to confirm the **likely** activation of the core catcher; the sampler includes many seals and a test run of the sampler should be carried out prior to sampling to ensure that all seals are working correctly.

It was found that sampling micaceous silts with the GP-S sampler was unsuccessful due to the large amount of swelling which occurred after the soil was captured in the core-liner barrel.

To date, the trials of the GP-TR sampler in New Zealand have not been able to produce high quality specimens. The trials however have been limited to clean sands, and it is likely that greater success might be obtained with this sampler in different soils, or with further refinement of the drilling procedures.

## 7 ACKNOWLEDGEMENTS

The authors wish to acknowledge the financial support of the Earthquake Commission, New Zealand (EQC), the Ministry for Business, Innovation and Employment.

During the sampling campaigns, the authors were grateful to receive technical advice, suggestions and experience from Prof. Kenji Ishihara and Mr Katsuo Sakai of Kiso-Jiban Consultants. Ms Nicole Van De Weerd conducted much of the laboratory testing described in this paper.

## 8 REFERENCES

- Fonseca, A.V. & Coutinho, R.Q.,(2008) Characterization of Natural Soils. In proc *Geotechnical and Geophysical Site Characterization*. 1-4 April, Taiwan. 195-248.
- Lee, W.F., Ishihara, K. & Chen, C.C. (2012) Liquefaction of silty sand – preliminary studies from recent Taiwan, New Zealand and Japan earthquakes. In proc. *Int. Symp. Engineering lessons learned from the 2011 Great East Japan Earthquake*. Tokyo.
- Jamiolkowski, M. (2014) Geotechnical characterization of a tailings deposit in Poland – an update. In proc. *3<sup>rd</sup> Int. Symp. Cone Penetration Testing*. Las Vegas.
- Osterberg, J.O. (1973). An improved hydraulic piston sampler. *Proc. 8th Int. Conf. on Soil Mechanics and Foundation Engineering*, Moscow. Vol. 1: 317–321.
- Stringer, M.E., Taylor, M.L. & Cubrinovski, M. (2015b) *Advanced soil sampling of silty sands in Christchurch*, Tech Rep. University of Canterbury, ISSN: 1172-9511
- Taylor, M.L., Cubrinovski, M. & Haycock, I. (2012) Application of new ‘Gel-push’ sampling procedure to obtain high quality laboratory test data for advanced geotechnical analyses. In proc. *2012 NZSEE Conference*. Paper No. 123
- Wotherspoon, L.M., Cox, B.R., Stokoe, K.H., Ashfield, D.J. & Phillips, R.A. (2015) Utilising direct-push crosshole technology to assess the effectiveness of soil stiffening caused by installation of stone columns and rammed aggregate piers. In proc. *6ICEGE*, Christchurch, New Zealand.
- Yoshimi, Y., Tokimatsu, K. & Ohara, J. (1994) In situ liquefaction resistance of clean sands over a wide range in density. *Geotechnique*. 44(3):479-494