

INTERNATIONAL SOCIETY FOR SOIL MECHANICS AND GEOTECHNICAL ENGINEERING



This paper was downloaded from the Online Library of the International Society for Soil Mechanics and Geotechnical Engineering (ISSMGE). The library is available here:

<https://www.issmge.org/publications/online-library>

This is an open-access database that archives thousands of papers published under the Auspices of the ISSMGE and maintained by the Innovation and Development Committee of ISSMGE.

Design of protective dolphins in difficult geotechnical conditions

A. Krivokapic

Ramboll, Denmark, ANDK@Ramboll.dk

H. Sjöstedt

Ramboll, Denmark

ABSTRACT

Many existing bridges are faced with urgency to increase safety due to vessel collision. A number of different approaches are possible depending on the set of constraints which are almost unique for a given project.

This paper describes the design of independent protective dolphins for the Sallingsund Bridge in Denmark. Two concrete structures, supported by tubular steel piles were designed to resist impact of vessels of up to 6000 deadweight tonnage (DWT) and prevent collision with the bridge piers. The design of the dolphins was preceded by risk analysis based on monitoring of the ship traffic through the channel and a concept study which narrowed down the choice of structural system.

The final solution was greatly influenced by the 15m water-depth and presence of a 15m thick layer of gyttja found immediately beneath the seabed, providing very little geotechnical resistance against lateral loads. The solution also had to fit many other constraints such as a limitation of the size of the structures, proximity of existing raked piles below the bridge pier, restrictive budget, etc.

Structural verification was done using state-of-art calculation methods, which took into account time history of the collision event, plastic behaviour of all structural elements (including the vessel), second order effects for piles and pile - group effect. Furthermore, the design was streamlined to maximize the dolphins overall energy dissipation capacity and is optimized with regards to the constructability in the near-shore environment.

Keywords: vessel collision, protection dolphin, gyttja

1 INTRODUCTION

Ship impact to a bridge from a larger vessel is a rare hazard which may have catastrophic consequences. A number of existing bridges do not have sufficient capacity required to resist the collapse of superstructure in the event of critical collision.

For any such bridge, a design of additional protection is required in order to reduce the risk level below the requirements given by the society and applicable codes.

In recent years, Vejdirektoratet (Danish Road Directorate which is the authority and main owner of roads and bridges in Denmark) has initiated assessments of four large marine bridges having unacceptably low safety against ship collision. Ramboll and COWI worked together with Vejdirektoratet on establishing the appropriate acceptance criteria to be met by protective measures following the principles of Eurocode system.

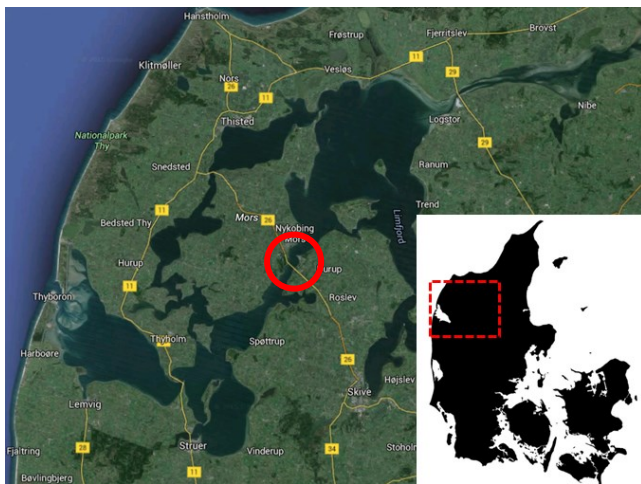

Figure 1 Limfjord (Sallingsund marked with red)

The largest of the analyzed bridges is Sallingsund Bridge, which was opened in 1978 in order to improve the traffic connection between the island of Mors and the Salling peninsula on the Danish mainland (Jutland) – see Figure 1. The total length of the bridge is about 1700 metres, each span between the piers is 93 metres long and the maximum vertical clearance to the sea is 26 metres.

The bridge is constructed of reinforced and pre-stressed concrete. The bridge deck is carried by 18 concrete piers, founded on driven tubular piles.



Figure 2 Sallingsund bridge

1.1 Risk analysis

The design was preceded by a comprehensive risk assessment which included a cost-benefit analysis in order to choose the right solution for the task within a given budget.

The assessment included analysis of vessel traffic through Sallingsund by collecting Automatic Identification System (AIS) data and incorporated mathematical models of vessel deflection upon the impact with a protection structure – see Figure 3.

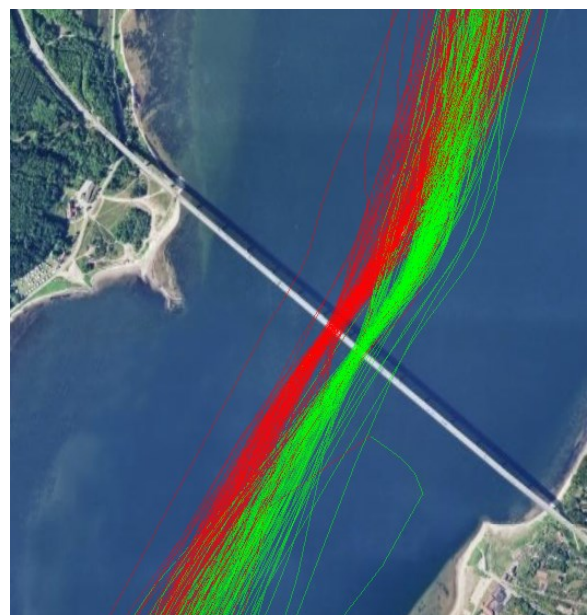

Figure 3 Overview of AIS data monitoring of the passing ships (red – southbound; green – northbound)

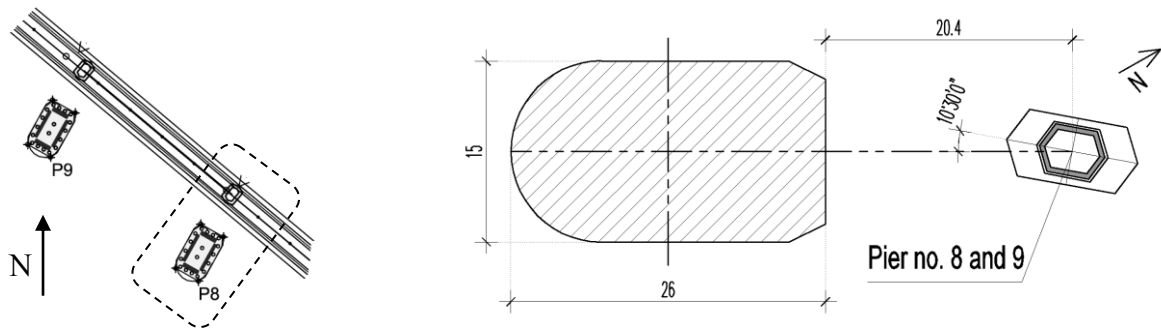

Figure 4 Placement of dolphin in relationship to the pier, overview (left) and detail (right)

The overall findings were that acceptable level of protection would be achieved by placing two independent protection structures south of piers 8 and 9 in order to protect these two piers against ship impact from northbound ships, as shown on Figure 4. The design vessel was adopted to represent the largest ship that can enter the Limfjord also taking into account planned deepening of the entrance channel from the North Sea. Design vessel properties are shown in Table 2.

The design speed of the ship was determined based on the AIS data and adopted as 4.8 m/s.

The dolphins were designed to fully absorb the kinetic energy from the moving ship and prevent it from hitting the pier.

Table 1 Design vessel characteristics

Vessel type	Ship
Displacement (partly loaded)	6000 t
Width	16 m
Length	97 m
Bow depth	16 m
Draft (partly loaded)	4.7 m
Rake length of bow	4 m

2 SITE CONDITIONS

2.1 - Geotechnical conditions

The water depth at the location of the dolphins is around 15 m. The topsoil consists of a layer of gyttja reaching 15m below the seabed.

The gyttja is followed by a sand layer (17-30m in vicinity of piers 8 and 9) under which there is a layer of mica clay - see Figure 5.

The gyttja layer is very porous and with almost negligible strength and stiffness. Therefore scour was not considered as an issue that affects the design assumptions. The thickness of the sand layer varies between pier number 8 and pier number 9.

Thicknesses and strength parameters of soil layers are shown in Table 2.

Preliminary design determined that the tip of the piles at the dolphin near pier 8 will end in sand layer with sufficient depth below to insure the full tip bearing capacity. The smaller thickness of the sand layer near pier 9 (in comparison to thickness at pier 8) meant that piles had to be extended into the clay layer making them considerably longer, much resembling those which support the bridge pier.

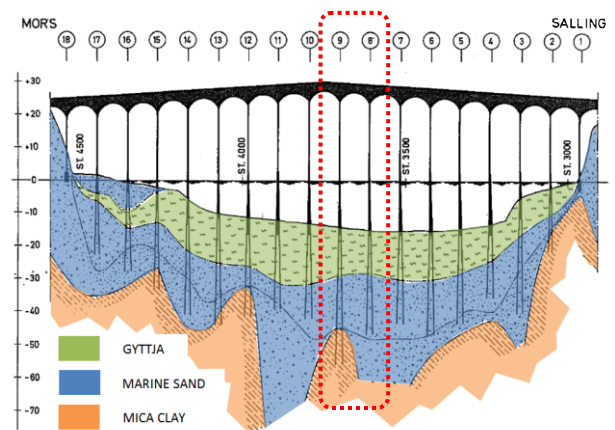

Figure 5 Overview of geotechnical layers which govern the foundation of the bridge

2.2 Existing piers and their piles

The bridge piers are founded on groups of circularly distributed driven piles in two rows, raked with 9% and 32% inclination outwards – see Figure 6. The piles are constructed as driven steel pipes with outer

Table 2 Geotechnical layers and properties

Level [m]		Soil type	c_u [kPa]	ϕ [°]	N_q [-]	γ' [kN/m ³]	r
Dolphin 8s							
-14.7	-28.3	Gyttja	0.0 – 16.3	-	-	1 – 1.5	0.92 – 0.7
-28.3	-39.7	Sand	-	33	26	9.5	
-39.7	-51.7	Sand	-	38	49	9.5	
-51.7	-54.7	Sand	-	39	56	9.5	
Dolphin 9s							
-14.0	-29.0	Gyttja	0.0 – 18.0			2	0.8
-29.0	-46.0	Sand	-	33	26	9.5	
-46.0	-51.0	Clay	80-130/100	-	-	8.0	0.4
-51.0	-65.0	Clay	130/100	-	-	8.0	0.4

diameter of 711.2 mm and maximal bearing capacity of 6000kN in compression.

Tip of the existing piles at pier 8 extends between levels -45.20 and -47.50.

At pier 9, the piles for the foundation of the bridge had to be extended into the clay to achieve required bearing capacity. Tubular piles end in sand (levels -40.0 to -43.0) with steel H pile driven further down into the clay (tip level between -54.13) and -57.80).

3 GEOMETRY AND DESIGN

Preliminary studies eliminated cylindrical sheet pile caissons filled with gravel as unsuitable to the geotechnical conditions. Instead, concrete dolphins on piles were chosen as the concept capable of meeting the capacity required for stopping the design vessel. This solution also provided flexibility regarding the shape in plan and construction methods.

As the dolphins are placed with their “strong” axis at a 10.5° out of the axis perpendicular to the bridge (see Figure 4), their size affects the available width of navigation passages. A requirement from the Søfartsstyrelsen (authority in charge of ship safety) was that a minimal navigable channel width of 60m must be maintained. The width of 16m was chosen for the dolphins to ensure sufficient shading of the piers. The distance between the dolphins and the piers was adopted based on minimal allowable distance between newly installed and existing piles taking into account driving tolerances and mutual interference. Concrete superstructure is identical on both dolphins.

In plan, the dolphin has elongated shape, with their southern edges rounded to increase the deflection capability.

The length of the dolphins was adopted as 24.4m to maximize the lever arm between the opposing rows of vertically loaded piles. The

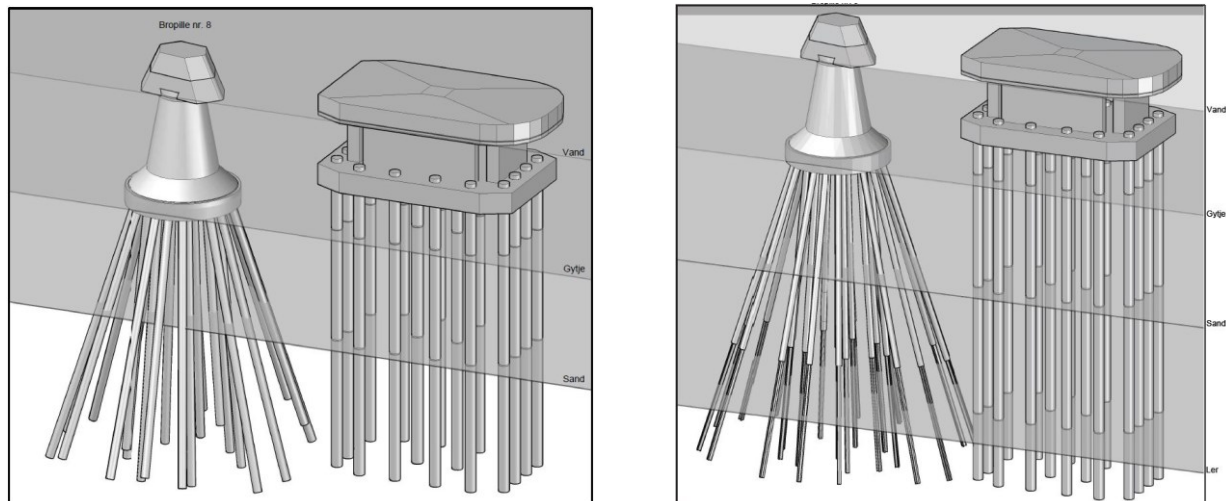

Figure 6 Isometric view of the dolphin and pier 8 (left) and 9(right)

concrete cap is a box-like structure, which consists of a concrete base slab, four walls and a top slab. Each dolphin is founded on 18 steel tubular piles, 1200mm in diameter. Isometric view of the dolphins in relationship to the bridge piers is shown on Figure 6.

The design was partially driven by consideration of the available construction methods. For example, maximal sizes of floating cranes and other construction vessels which can enter the Limfjord were taken into account when the size of prefabricated sections of superstructure was decided. Driven piles were chosen over the bored shafts. It was considered that for this scope of works, latter choice would be burdened with higher price and lower availability of required construction equipment. The diameter of the piles was chosen as the best compromise between structural requirements, economy and execution concerns.

Driven piles offered the added benefit that the driving log allows for a precise estimate of the bearing capacity without additional testing.

Another important feature of the chosen pile system is that the largest contribution to the pile's vertical/axial capacity comes from the skin friction resistance (both inside and outside), which has a ductile post-yield behaviour. As shown later in this paper, this is an important feature in the system that allows for vertical yielding of piles (plastic segment of the diagram) during the collision. Possible increase of the pile tip area by under-reaming and filling with concrete was excluded as the larger tip resistance obtained in such way is hard to verify and produces brittle failure.

The combined depth from water surface to load bearing soil layers is around 30m (due to the presence of gyttja). With chosen pile diameter, design with a pinned connection between piles and superstructure would require too large deformations in order to stop the colliding vessel.

This challenge was met by designing a cap with extended height in order to shorten the free length of the piles, and by providing a

fixed connection between piles and bottom slab.

As the consequence, vertical resistance of the piles was activated through the lever arm between the rows in tension and compression which resulted in the increase of overall structural stiffness.

The ability of the piles to retain maximal moment in the post-yield stage was achieved by maintaining the wall thickness-to-diameter ratio needed to satisfy requirements for compact cross-section class (class 1). As the result, piles were designed with wall thickness of 40mm in expected zones fixation and reduced further down where piles are subjected to normal forces only.

4 MODELLING AND ANALYSIS

The general approach to the design of independent protective structures is to demonstrate that the kinetic energy of the ship can be dissipated through plastic work and acceleration of the mass.

In order to do this, the working curve of the dolphin was obtained by creating a full static model of the structure in the FE software. Model incorporated several non-linear effects such as: horizontal and vertical response of the soil, nonlinear behaviour of the steel in the piles and second order effects (geometric nonlinearities).

4.1 Modelling of geotechnical conditions

The horizontal response of the surrounding soil was modelled using PY-curves which describe the dependency between reaction force, P , in the soil and lateral deformation, Y , of the pile. The PY-curves also vary with type and strength of soil and depth beneath the sea bed as shown on Figure 7.

Group effect was taken into the consideration by reduction of the P -values of the PY-curves for given deformation. Different reduction factors were used depending on the geometric position of the piles with values between 0.6 and 0.95.

The gyttja provides negligible resistance against lateral load compared to the sand layer below where fixation is achieved after

2-3m. The lateral resistance in the clay layer (which is found beneath the sand layer) is irrelevant. Still, it is included in the FE model.

The vertical resistance of the piles is a combination of skin friction and tip resistance. For a plugged pile, the skin friction acts on the outer circumference of the piles, whereas the tip resistance acts on the cross sectional area of the piles and the area of the enveloped soil. For an unplugged pile, the skin friction acts on the inner and outer circumference of the piles and the tip resistance acts on the cross sectional area of the pile’s wall. However, to simplify the modelling of the dolphins, the sum of both skin frictional resistance and tip resistance was applied at the tip of the piles, by use of a piecewise linear spring, a TZ curve.

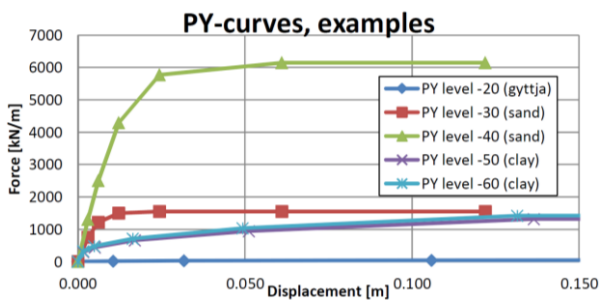
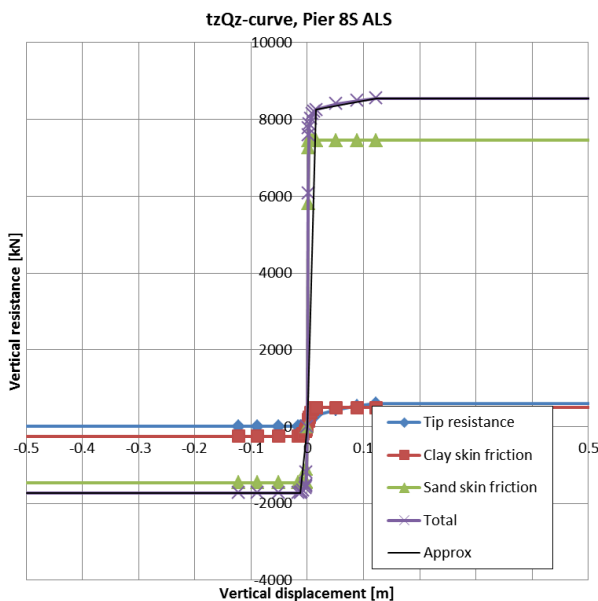

Figure 7 Examples of PY-curves used for piles at pier 9.

Typical examples of such a spring’s properties are shown in Figure 8. The group effect was also investigated for vertical



loading of the piles and it was found that it had no influence due to sufficient spacing between the piles.

4.2 Modelling of structural elements

The static model of the dolphin corresponds to a sway frame with piles fixed to the concrete super structure and fixation developed in the sand layer – see Figure 9. Yield hinges are expected to develop in the piles at the zones of maximal moments.

The global overturning moment caused by the impact load acting over the vertical distance between the top slab and the level of fixation, augmented by the second order effects, is resisted in two ways: - 1) through compression / tension action of the opposing pile rows and 2) through moment in each individual pile at the fixation level.

The steel piles are modelled as beam elements with perfect elasto-plastic behaviour. This means that bending moment can only increase in the pile until the von Mises yield criterion is reached. Thereafter, the moment is kept constant (or decreases if the normal force increases) with increasing rotation as the yield hinge is formed. Geometric imperfections were taken into account through applying initial fictive horizontal loading to the beam elements.

All concrete parts were modelled as shell elements with linear material properties. The concrete structural elements were designed to transfer the loads from the ship impact

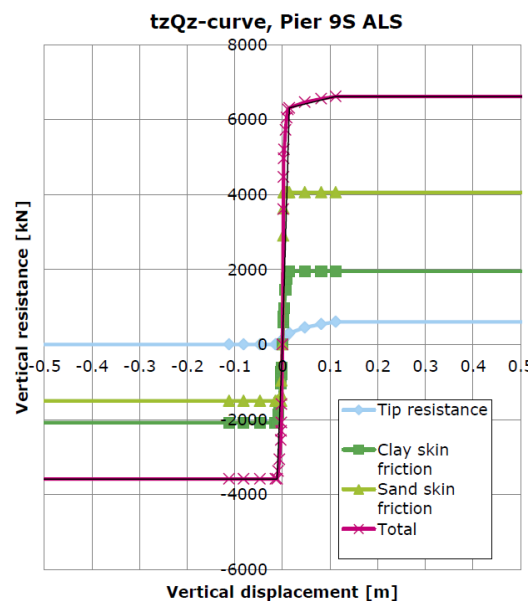

Figure 8 Components of the pile vertical capacity at piers 8 and 9 – TZ curves

without considerable plastic deformations.

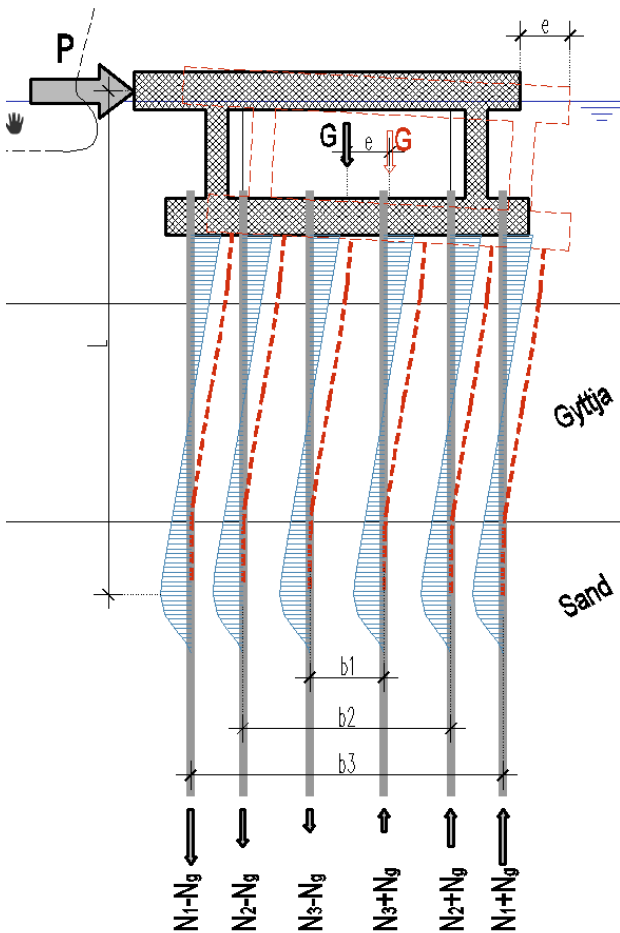

Figure 9 Static system

A horizontal point load of 1000 kN was applied at the top slab (level +1,5), as shown in Figure 9. The load was applied in iterative elasto-plastic analysis, with increasing multiplication factor assigned to each step.

Based on the horizontal deflection of the top slab and the corresponding load factor, a force – deformation diagram or “work curve” was plotted – see Figure 10.

The area beneath the diagram is equal to the dissipated energy of the system through plastic work. Therefore, “work curve” is used to determine the required deflection in order to dissipate the energy from the collision. At the same time, it is used to derive equivalent static impact load to be used for verification of the concrete super structure elements can be found.

The analysis is performed for head-on collision and oblique impact with a deviation angle of 30°. This angle is chosen as maximal proposed by AASHTO without reduction in the collision energy dissipation requirements. This is done in order to insure sufficient lateral stiffness of the dolphin.

5 RESULTS

5.1 Dolphin capacity

Obtained “work curve” of the described iterative elasto-plastic analysis is shown on Figure 10. The corresponding values of the normal forces in piles are shown on Figure 12 and deformed configuration of dolphin 9S is shown on Figure 11.

Only the results of the head on collision are presented here. Results of the oblique impact analysis are the subject of a future publication.

The load-deformation diagram of the structure has a steep linear shape up to the point where two front and rear rows of piles yield in compression / tension and yield hinges have developed in all of the piles. This point marks the peak load factor that the structure is able to resist (denoted by “1” on Figure 10).

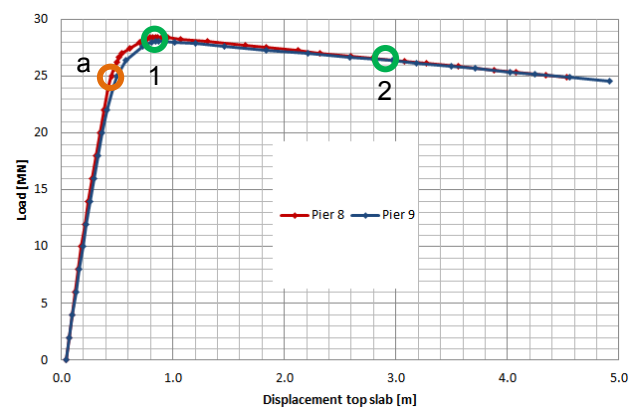

Figure 10 Load-displacement curve of the dolphin 8(red) and 9 (blue)

Prior to reaching the peak value, the curve drops in angle from the previous linear load-deformation response of the dolphin. At this point (marked with “a”), front piles have

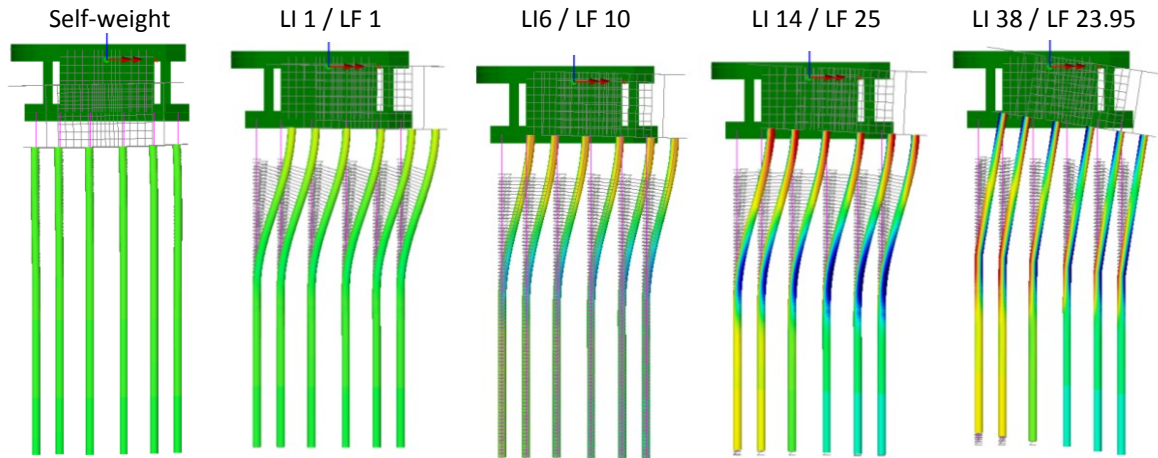

Figure 11 Successive deformed configurations of the dolphin (LI – load increment, LF – load factor)

almost exhausted their normal bearing capacity in skin friction which has a steeper TZ curve compared with the tip.

Past the point “1”, the deflection continues to increase and the global overturning moment is kept constant. Since the influence of second order effects increases with deflection gain, the load factor will decrease simultaneously.

The “work curve” shows that dolphin is capable of deforming further which could indicate that the design is conservative. However, the overall stiff behaviour of the dolphin ensures stopping of the vessel on safe distance from the pier. Also, in the marine environment susceptible to ice loads, stiff structure is less susceptible of inducing unintended damage.

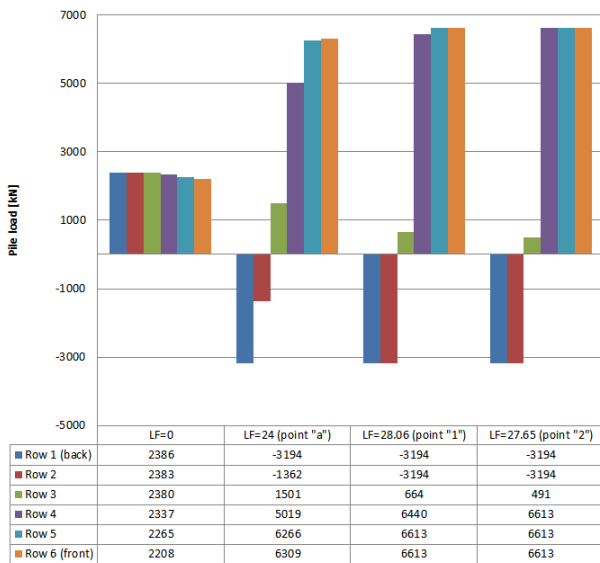

Figure 12 Overview of the development of normal forces in the piles compared to the load factor (each coloured bar corresponds to one row of piles and positive values represent compression)

Point “2” indicates the deformation at which the required kinetic energy of the colliding vessel is dissipated by the plastic work of the system. Displacement of the top slab is around 2.9m for both dolphins.

5.2 Energy exchange

Apart from plastic work performed by dolphin structure during the collision, impact energy is absorbed by several other mechanisms. Formost is the crushing of the ship’s bow, which is described with non-linear curves in both AASHTO and Eurocode. Curves that describe the dependency between force and deformation are based on the physical experiments (Woisin and Meir-Dornberg).

Simplified curves and maximal values of quasi-static impact forces given in various sources show considerable disparity among each other. This is discussed in AASHTO and there is awareness that this is an area of ongoing research.

In this project, energy exchange between vessel and the dolphin was assessed using time series analysis based on the conservation of momentum at the moment of impact and conservation of energy for motion after the impact. The model is described as two-degrees-of-freedom system connected by

piecewise linear longitudinal springs as shown on Figure 13. Spring of the dolphin is modeled after obtained “work curve” and the ship’s bow force-deformation curve is adopted from annex C4.4 of EN 1991-1-7.

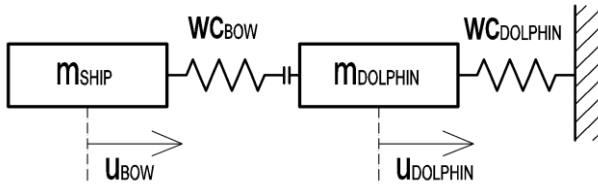

Figure 13 Simplified model for collision analysis

The interaction between the ship and dolphin is simulated using time series analysis performed with in-house developed program.

Due to relatively large mass of the concrete superstructure compared to the displacement of the vessel, it was assessed that up to 60% of the collision energy could be dissipated by deformation of the bow. However, the assumptions regarding the ship’s bow behaviour incorporate substantial uncertainties. Furthermore, recent studies based on detailed FEM models of ship’s bow, indicate lower yield load. Collision with deformable structure could limit the deformation of the bow, thereby reducing the amount of energy dissipated in this way. For this reason, dolphin’s pile system, is verified without relying on this mechanism of collision energy dissipation.

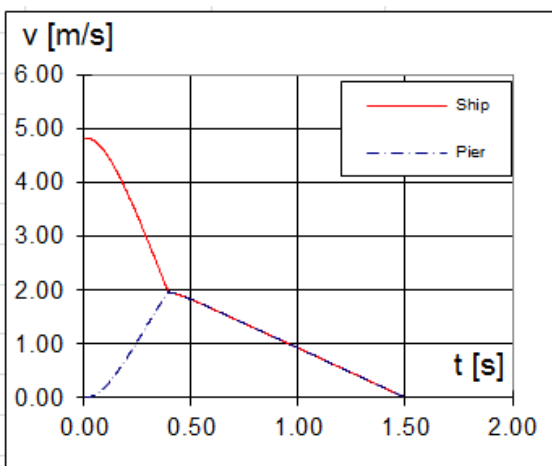

Figure 14 Speed of ship and dolphin over the time

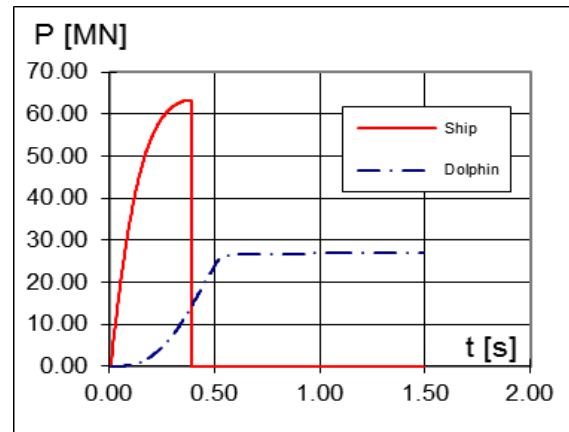

Figure 15 Force in ship’s bow and dolphin

5.3 Concrete super structure

Concrete super-structure is dimensioned for the difference between maximal forces in the bow and dolphin shown on Figure 15. The assumption of the peak quasi static force to act on the concrete structure is in this case a conservative assumption. As the peak force is larger than maximal force that can be taken in the pile system, separate model was made where the piles were given unyielding vertical support. In this way, it is ensured that impact load can be transferred by the superstructure and distributed on the pile group as assumed.

6 CONCLUSION

The presented solution successfully meets multiple-constrained design requirements through integration of all available structural and geotechnical energy dissipating components.

The presence of a thick layer of weak organic soil excludes a number of solutions and poses execution and design challenges. With limitation on pile diameter and construction method, the required response of the structure is achieved by an extended concrete superstructure and moment-coupled connection to the piles.

This was facilitated by a concurrent geotechnical and structural design process which verified ductile post-yield behaviour of all elements.

Further possibilities for optimization of future similar structures can be explored

through more advanced modelling of energy transfer between the ship and the dolphin.

7 REFERENCES

AASHTO (2007), Guide Specifications and Commentary for Vessel Collision Design of Highway Bridges, 2nd edition

Eurocode (2007), DS/EN 1991-1-7:2006 General Actions – Accidental Loads (including DK NA:2007), 2nd edition