

INTERNATIONAL SOCIETY FOR SOIL MECHANICS AND GEOTECHNICAL ENGINEERING



This paper was downloaded from the Online Library of the International Society for Soil Mechanics and Geotechnical Engineering (ISSMGE). The library is available here:

<https://www.issmge.org/publications/online-library>

This is an open-access database that archives thousands of papers published under the Auspices of the ISSMGE and maintained by the Innovation and Development Committee of ISSMGE.

Design of Ro-Ro berth breasting dolphin pile foundation in the port of Koper

Conception de duc D`Albe pieu fondation de la jeteé roulante dans le port de Koper

B. Velkavrh

OPI Inter, Ljubljana, Slovenia

B. Pulko

Faculty of Civil and Geodetic Engineering, University of Ljubljana, Slovenia

L. Battelino

OPI Inter, Ljubljana, Slovenia

ABSTRACT: In the Port of Koper new Ro-Ro berth for ships of length of about 240 m is planned. Therefore, it is necessary to construct a new berth with several breasting and mooring dolphins. The conventional concept is to transfer the horizontal ship forces to the ground via embedded steel pile or group of piles, where piles are embedded into the ground and loads transmitted directly from the pile(s) into the ground. As it was found out that thick deposit of very soft soils below the seabed is unable to provide the necessary lateral support to the steel pile. Thus, alternative design had to be adopted. To reduce the lateral pressures on the pile-soil interface and to increase the load capacity and lateral stiffness, an additional reinforced concrete (RC) block was initially proposed at the level of the seabed floor in order to transfer more load into the soil. However, due to the thickness of very soft soil below the seabed, this measure proved to be insufficient. Therefore, the idea was to support the concrete block with 4 additional steel piles in order to maximize the load transfer from the main pile to the supporting structure at the seabed level and to increase lateral stiffness. Several nonlinear numerical 3D analyses were made considering different designs and constitutive soil models. For the steel pile and RC block elastic behavior was adopted. The 26.8m long pile supported by RC block and additional piles $\phi 508\text{mm}$ were adopted as final design.

RÉSUMÉ: Dans le port de Koper on veut construire une jetée roulante pour des navires atteignant jusqu'à 240m de longueur hors tout. Il a fallu pour cela projeter plusieurs duc d'Albe d'accostage et d'ancrage pour permettre un accostage. Le principe fondamental consiste à transmettre les forces horizontales provenant du bateau au sous-sol grâce à un pieu métallique qui y est enfoncé pour que ces forces puissent être directement transmises au sous-sol. On a constaté que la couche du sol n'avait pas l'épaisseur requise c'est pourquoi la nécessité de concevoir une alternative fiable s'est imposée. Ensuite, il a été proposé de mettre un caisson en béton armé au niveau de la dalle au fond de la mer. Qu'importe, suite à une épaisseur insuffisante des couches des sols tendres des fonds marins et leur faible portance, cette mesure s'est relevée peu effective. Ce pieu métallique incorporé dans le caisson en béton armé renforcé aux extrémités par quatre petits pieux complémentaires, s'est imposé comme solution optimale.

Keywords: Breasting dolphin; steel piles; numerical modelling; soil-structure interaction

1 INTRODUCTION

In the Port of Koper (Slovenia) a new Ro-Ro berth for ships of maximum length of about 240 m is planned in Basin III. Therefore, it is necessary to construct a new berth with several breasting and mooring dolphins. The conventional concept is to transfer the horizontal ship forces to the ground via embedded steel pile or group of piles, directly from the pile(s) into the ground. Due to thick deposit of very soft soils below the seabed, which is unable to provide the necessary lateral support to the single steel pile, an alternative design with additional support at the seabed floor was adopted. The aim of this paper is to present conceptual solutions with an overview of the performed analyses.



Figure 1. Plan view at seabed level

2 CONCEPTUAL DESIGN

The basic structural design and calculation model of Ro-Ro breasting dolphin and ground composition are shown in cross-section in Fig. 2. The ground below the sea floor consists of very soft marine sediments, predominately soft clays, overlaying the marlstone bedrock. The predicted horizontal force on the breasting dolphin is

1020kN, acting 3m above the sea level (MSWL).

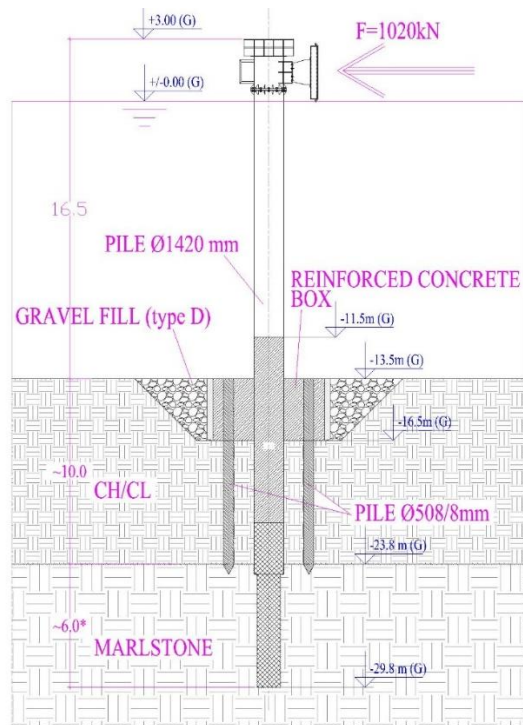

Figure 2. Cross section

In order to assure the appropriate bearing capacity of breasting dolphin, four different design types were proposed and checked by means of 3D numerical analyses as follows:

- Breasting dolphin made of tubular steel pile with a diameter of 1420mm and thickness ranging from 20 to 36mm, without any additional support.
- Breasting dolphin made of tubular steel pile filled with concrete C30/37 under -11.5m MSWL with a diameter of 1420mm and thickness ranging from 20 to 36mm with additional 3m thick gravel blanket with an area of 6×8m at the seabed floor.
- Breasting dolphin which consists of steel pile filled with concrete C30/37 under -11.5m

MSWL with a diameter of 1420mm and thickness ranging from 20 to 36mm and reinforced concrete block with dimensions of 6×8×3m placed at the sea bottom supported with 4 additional steel piles (ϕ 508/8mm).

- D. Breasting dolphin made of tubular steel pile filled with concrete C30/37 under -11.5m MSWL with a diameter of 1420mm and thickness from ranging from 20 to 36mm with reinforced concrete block with dimensions of 6×8×3m placed at the sea bottom and backfilled with gravel and supported with 4 additional steel piles (ϕ 508/8mm) with gravel backfill around concrete block as shown in Fig. 1 and 2.

3 BASIS OF STRUCTURAL DESIGN AND MATERIAL DATA

3.1 Construction data

The breasting dolphin main element consists of tubular steel tubes with outer diameter of 1420mm and thickness ranging from 20 to 36mm. It was modeled as an elastic circular steel tube with varying axial and bending stiffness along the dolphin.

The 3m thick reinforced concrete block with floor dimensions of 6×8m is made of concrete C30/37 and is considered as an elastic material having Young's modulus $E = 31$ GPa and Poisson's ratio of 0.2.

The tubular steel piles with a diameter of 508mm and a thickness of 8mm ($E = 200$ GPa, $\nu = 0.2$) were foreseen to provide additional support to the breasting dolphin below the sea floor. These were modeled as special Plaxis 3D elements - embedded piles with constant axial and bending stiffness and with layer dependent axial skin resistance.

3.2 Soil data

The ground below the seabed at the depth of approx. -13.5m below the sea level consists of

three layers. The top, up to 6.5m thick layer, is made of soft marine sediments. The layer of weathered marlstone is up to 4m thick and overlays the marlstone bedrock.

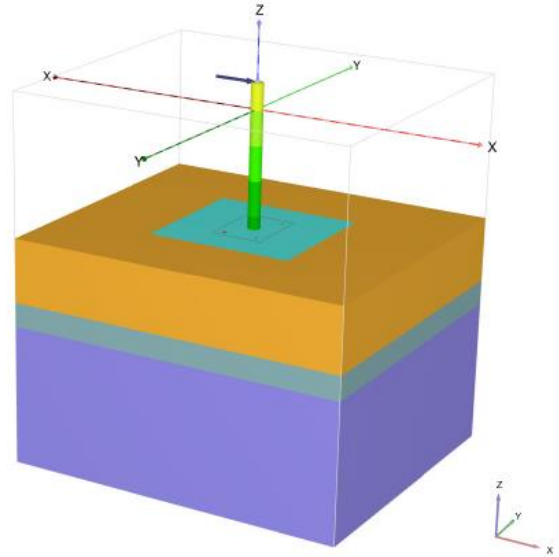

Figure 3. Numerical model (Plaxis 3D)

Table 1. Soil properties (Mohr-Coulomb model)

| | Clay | Weath. marlstone | Marlstone | Gravel |
|---|------|------------------|-----------|--------|
| Parameter | | | | |
| Unit weight γ (kN/m ³) | 17 | 23 | 24.5 | 21 |
| Young mod. E (MPa) | 0.56 | 30 | 50 | 20 |
| Poisson's ratio ν | 0.35 | 0.3 | 0.3 | 0.3 |
| Cohesion c' (kPa) | 1 | 200 | 500 | 0 |
| Shear angle ϕ' (°) | 21 | 28 | 32 | 35 |
| Dilation angle ψ (°) | 0 | 0 | 5 | 5 |
| Stiffness incr. E_{inc} (MPa/m) | 0.13 | 0 | 0 | 0 |
| Reference depth z_{ref} (m) | - | 0 | 0 | 0 |
| K_0 | 0.64 | 0.53 | 0.47 | 0.43 |

The finite element analyses using the numerical model shown in Fig. 3, were performed by taking into account the Mohr-Coulomb (MC) model, where cautious soil material parameters were adopted based on in-situ and laboratory tests.

Alternatively, the advanced nonlinear Hardening Soil model (HS) was used for the clay layer due to its significant influence on deformation behavior of the structure.

The adopted material properties (MC model) are shown in Table 1 and those for clay using HS model in Table 2.

Table 2. Soil properties - clay (HS model)

| Material parameter | Unit | Type/Value |
|------------------------------|-------------------|------------|
| Unit weight γ | kN/m ³ | 17.0 |
| E_{50}^{ref} | MPa | 2.68 |
| E_{oed}^{ref} | MPa | 2.14 |
| E_{ur}^{ref} | MPa | 19.0 |
| Power (m) | | 1.0 |
| Cohesion c' | | |
| Shear angle ϕ' | ° | 21.0 |
| Dilation angle ψ | ° | 0.0 |
| Poisson's ratio ν_{ur} | | 0.2 |
| Reference pressure p_{ref} | kN/m ² | 100 |
| K_0^{nc} | - | 0.642 |

4 NUMERICAL ANALYSES

The finite element (FE) analyses were performed with Plaxis 3D software. Four different design schemes were analyzed under short term (undrained) and long-term (drained) conditions. In order to compare the results, the MC model and HS model were used for the clay layer. The analyses considered the following design situations:

- Drained state under horizontal load of 1020kN.
- Drained state of the dolphin after complete unloading from 1020kN in order to calculate the permanent plastic displacements of structure.

- Undrained state under horizontal load of 1020kN (short term loading).

The similarity between dolphin displacements calculated for the drained and undrained state indicates that they are mostly a consequence of distortion and not due to volumetric strains. With the displacements being larger for the drained state, undrained unloading was not considered in the analyses.

4.1 Deflections at the dolphin top

The maximum calculated deflections under the horizontal force of 1020kN acting at the top of the dolphin (+3.0m MSWL) are shown in Table 3 for all four proposed design types. According to the proposed design type, the values of dolphin top deflection are between 33.2cm for the type D and 70.2cm for the type A, of which approximately 23.5cm is an elastic deflection of the dolphin steel tube ($\phi 1420$ mm), if considered fully clamped at the depth of the seabed (-13.5m SWL).

It should be noted, that similar values of deflections were obtained, regardless of the adopted material model for the clay layer.

If design types A and B are compared, one would expect a greater reduction of deflections because of the additional gravel fill around the dolphin. However, the results of numerical analysis for the type B also showed large seabed shifts around the breasting dolphin. Due to the very soft clay and inability to appropriately densify the gravel, only a small amount of the gravel fill resistance can be activated as the steel tube penetrates laterally through the gravel fill.

As for the influence of gravel fill on deflections, the same applies also for the design types C and D, where additional support with reinforced concrete box and four supporting piles $\phi 508/8$ mm are foreseen to reduce the dolphin deflections.

Table 3. Maximum deflections at the top of breasting dolphin

| Clay material model: | HS | HS | HS | MC | MC | MC |
|--|----------------------------------|--|------------------------------------|----------------------------------|---|--------------------------------------|
| Type of analysis: | U_{\max} drained loading | U_{final} drained unloading | U_{\max} undrained loading | U_{\max} drained loading | U_{final} drained re- lief | U_{\max} undrained unloading |
| Case / Unit | [cm] | [cm] | [cm] | [cm] | [cm] | [cm] |
| A | 70.2 | 11.7 | 66.5 | 69.7 | 10.1 | 66.4 |
| B | 63.4 | 10.4 | 60.0 | 65.1 | 12.2 | 62.4 |
| C | 35.1 | 4.2 | 32.0 | 35.9 | 2.9 | 33.6 |
| D | 33.2 | 4.4 | 29.8 | 34.1 | 4.3 | 32.3 |
| Elastic deflection of the fully clamped steel tube above the seabed at -13.5 m ($L = 16.5$ m) | 23.5 | 0 | 23.5 | 23.5 | 0 | 23.5 |

4.2 Structural displacements

The structural displacements at the seabed for design type D, considering the state with the largest calculated deflections (HS model, drained conditions) are shown in Figs. 4 to 6.

The calculated horizontal displacement of RC block under the maximum load of 1020kN is about 4mm with small rotation, where vertical displacements on the edges of the RC block do not exceed $\pm 1,6$ cm.

The reinforced concrete pile (tube core) between the top at -11.5m MSWL and the bottom of the dolphin at the depth of 29.8m was modeled as an elastic material with 3D volume elements. Corresponding displacements beneath the seabed floor are shown in Figs. 4 and 6.

Once the calculated displacements were considered acceptable and the serviceability limit state (SLS) according to EN 1997-1 was fulfilled, structural design was followed according to Eurocode standards.

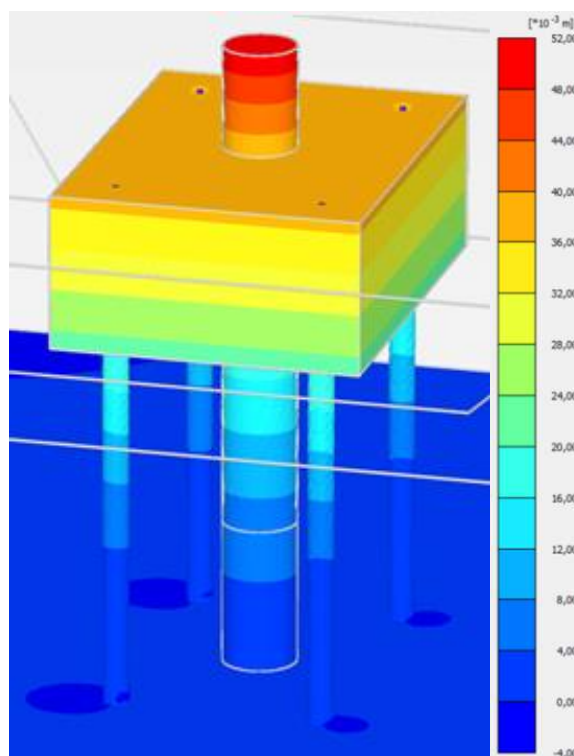

Figure 4. Horizontal displacements beneath the seabed U_x [m] - type D

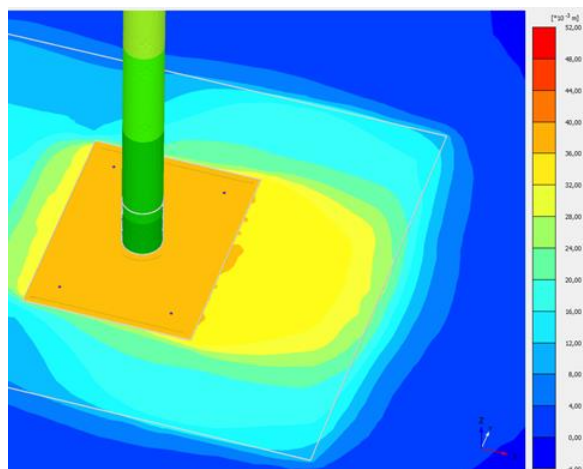

Figure 5. Horizontal displacements at the seabed (-13.5m) - type D ($U_{x\text{max}} \approx 5\text{cm}$)

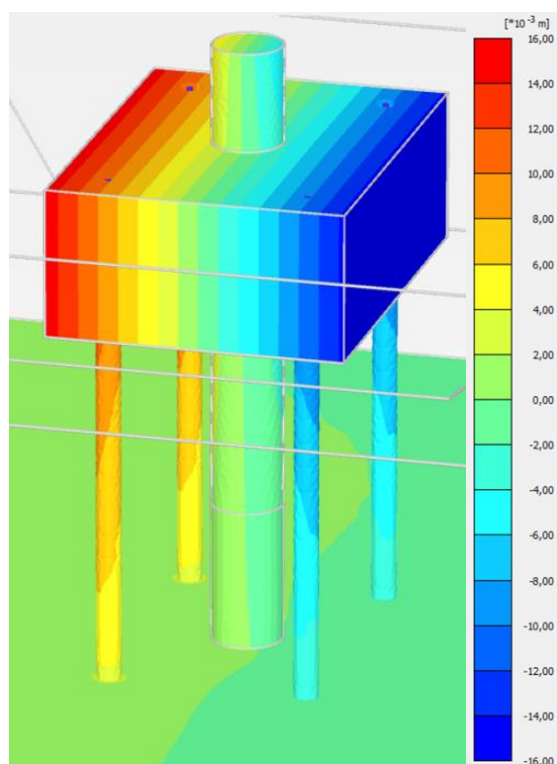

Figure 6. Vertical displacements U_z [m] beneath the seabed - type D ($U_z \approx \pm 1.6\text{cm}$)

5 CONCLUSIONS

The breasting dolphins can be designed as a single-pile flexible dolphins or multiple-pile rigid dolphins. In the presented case, the request was made by the port authorities to design a flexible single-pile dolphin (above seabed floor) sufficiently embedded in the seabed soil to transfer the static horizontal load of 1020kN. Due to very soft ground conditions, four different design solutions were proposed and analyzed in order to achieve required load-deflection behavior and required safety.

The design type A, which consists of a single steel pile embedded in the soft seabed, has shown too large deflections, even in the case where additional gravel blanket was placed around the pile at the seabed floor (type B). The 3D FE analyses performed for the design types C and D, where additional support of the dolphin by RC block and 4 steel piles was considered, have shown that the design requirements could be met. Although both types showed similar behavior in terms of deflections and safety, type D was selected as the final design. The reason is the construction sequence. The construction of reinforced concrete block requires a seabed excavation, which is much easier to fill with gravel than with excavated clay.

The 3D finite element analyses have proven to be useful in design of demanding port structures, where it is difficult to employ simple analytical methods.

6 REFERENCES

- ZRMK, Geological-geotechnical report - ground investigations in Basin III, Port of Koper, November 2015, report No.: GEO-2005610, Slovenia,
- OPI-Inter, Project of breasting dolphins for Ro-Ro berth in Basin III, Port of Koper,; April 2018, project No.: 105-2016, Ljubljana, Slovenia,