

INTERNATIONAL SOCIETY FOR SOIL MECHANICS AND GEOTECHNICAL ENGINEERING



This paper was downloaded from the Online Library of the International Society for Soil Mechanics and Geotechnical Engineering (ISSMGE). The library is available here:

<https://www.issmge.org/publications/online-library>

This is an open-access database that archives thousands of papers published under the Auspices of the ISSMGE and maintained by the Innovation and Development Committee of ISSMGE.

The paper was published in the proceedings of the 10th International Conference on Physical Modelling in Geotechnics and was edited by Moonkyung Chung, Sung-Ryul Kim, Nam-Ryong Kim, Tae-Hyuk Kwon, Heon-Joon Park, Seong-Bae Jo and Jae-Hyun Kim. The conference was held in Daejeon, South Korea from September 19th to September 23rd 2022.

Modelling of an integral bridge abutment under cyclic thermal loading

D.G. Morley & G.S.P. Madabhushi
University of Cambridge, Cambridge, U.K.

I. Thusyanthan
Gavin & Doherty Geosolutions (GDG) Ltd., U.K.

R. Shires
National Highways, U.K.

ABSTRACT: The jointless integral bridge eliminates maintenance associated with corroded bearings and expansion joints and has been widely adopted around the world to meet infrastructure resiliency and climate targets. Seasonal temperature change causes cyclic movements of the bridge deck leading to stress build-up in the retained backfill, a phenomenon that is inadequately understood and hence treated over conservatively in current design practice. In this research a centrifuge model was developed to replicate the cyclic movement of a 9 m integral abutment. Details of the actuation system development, scaling laws, and instrumentation are provided, as well as that of a Swandyne FE model used to estimate the actuator force requirement. LVDT and load cell results are given for a preliminary 60g centrifuge flight demonstrating system adequacy. This paper provides a basis for integral bridge model design but more broadly paves way for the investigation of how soil-structure stiffness influences stress ratcheting in granular soils.

Keywords: Integral bridges, retaining walls, soil ratcheting, cyclic loading, physical modelling.

1 INTRODUCTION

Bridges are often found in disrepair attracting a large proportion of infrastructure maintenance expenditure, reportedly at around 40% in the U.S. (Sakulich & Bentz, 2012). The reduction of bridge maintenance is key to increasing infrastructure resilience to climate change, reducing lifecycle carbon emissions, and preventing the economic impact of road and rail delays.

Conventional bridges suffer from the seizing of metallic components, specifically the bearings and expansion joints. Integral bridges avoid this with their jointless structure as shown in Fig. 1 which has led to their global adoption. However, a lack of joints leaves integral bridges vulnerable to thermal affects. Deck expansion during high temperatures generates pressures in the retained backfill which can increase over annual cycles as ratcheting occurs. Uncertainty in this pressure build up has led to overly conservative design and restriction of integral bridge use to only moderate spans and skews (Sandberg et al., 2020).

There is a need to study integral bridge behaviour through physical models to reduce design over-conservatism. This research describes efforts to create a centrifuge model, describing the overall setup, actuation system development, and use of FE analysis to inform model design.

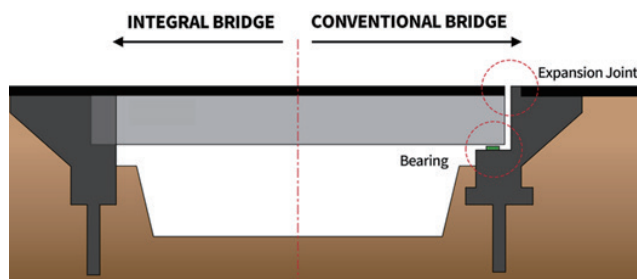

Fig. 1. Integral versus conventional bridge (Midas Bridge, 2022).

2 MODELLING OF AN INTEGRAL BRIDGE

A small-scale centrifuge model was developed for testing within the 10 m diameter Turner beam centrifuge at the Schofield Centre, University of Cambridge (Schofield, 1980).

2.1 Prototype scenario

Integral bridge design varies regionally based upon successful experience. Both foundation type and abutment height effect behaviour due to their influence on relative stiffness of soil and structure. Low-height bank pads on piles are common in the U.S., while in the U.K. it is typical to have full-height frame abutments on shallow foundations. This latter case was used for the prototype structure to observe pressure generation down

a large abutment as well as the impact of relative stiffness. Based on the geometry of several constructed integral bridges, as well as physical and numerical models reported in literature, a prototype configuration of 9 m wall height, 6 m base width, and 1 m wall and base thickness was taken.

2.2 Centrifuge model

The prototype was modelled in plane strain with the abutment spanning the full strong box width, founded on and retaining a granular soil, with deck thermal movements simulated with a mechanical actuation system. An interchangeable base allowed both a fixed and pin connection to the spread footing to replicate the small-scale tests of England, Tsang, & Bush (2000). Omission of the bridge deck gave simplicity neglecting the influence of its axial stiffness, length and abutment connection on pressure build-up (Card & Carder, 1993). An internal framing was designed to fix the actuator to the abutment with a clevis to prevent moment transfer.

The prototype was scaled to fit within a strong box of 790 × 560 × 200 mm as shown in Fig. 2. An enhanced acceleration of 60g was chosen as the lowest value at which the prototype could be scaled hence minimising errors with increasing acceleration. The horizontal 790 mm dimension gave the main constraint having to accommodate the actuation system, foundation base and passive soil failure wedge.

Scaling of the structure was according to flexural rigidity to give parity of stiffness with the prototype. Aluminium alloy was used for ease of fabrication and flexibility giving a model thickness of 12 mm. The granular material used was Hostun HN31 silica sand with a high relative density. Applied strain rate was not a focus given the dry, cohesionless nature of the soil (Springman, Norrish, & Wilkinson, 1994). Instrumentation to capture soil ratcheting included PIV for displacements, strain gauges for bending moments and the Tekscan pressure measurement system for earth pressures on the wall. Actuator force and displacements were measured with a load cell and LVDT.

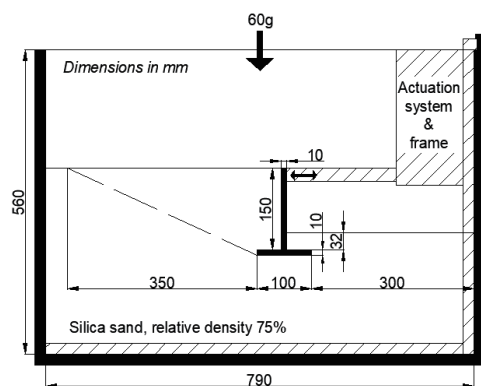

Fig. 2. Centrifuge model integral abutment.

3 FE MODELLING

Computational modelling was undertaken prior to testing to inform the actuation system requirements, predict usefulness of findings, and to be calibrated from subsequent centrifuge results. While particle rearrangement causing strain ratcheting cannot be captured in the FE method, many authors including Sandberg et al., (2020) have shown that stress and strain generation can be well-approximated with careful selection of constitutive law. A finite element model with the elastic-plastic Mohr-Coulomb V hardening law with non-associated flow was implemented in the Swandyne FE code (Chan, 1988). This was calibrated against the small-scale tests of England, Tsang, & Bush (2000) before the prototype scenario was created.

3.1 FE model properties

A mesh of 8 noded isoparametric, quadrilateral elements was created, as shown in Fig. 3, with properties of the soil, abutment and interface elements provided in Table 1.

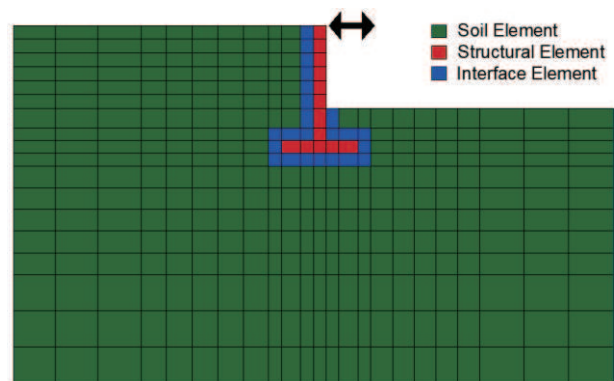

Fig. 3. Integral bridge abutment FE mesh.

Table 1. FE model material properties.

	Soil	Abutment	Interface Elements
Constitutive Model	Mohr-Coulomb V	Elastic	Slip Element
Elastic Modulus	300 MPa	30 Gpa	300 Mpa
Friction Angle	40°	-	40°
Dilation Angle	5°	-	-
Poisson Ratio	0.3	-	-
Void Ratio	0.6	-	-
Hardening Parameter	50	-	-

3.2 Displacement-controlled analysis

A displacement-controlled analysis prescribed a sinusoidal function to the top node of the abutment for 120 cycles with various peak magnitudes, mimicking deck thermal movements. The lateral earth pressure distribution after strain ratcheting is shown in Fig. 4:

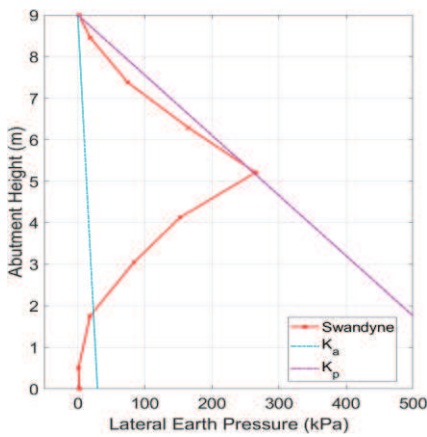

Fig. 4. Lateral earth pressure distribution after ratcheting cycles.

3.3 Force-controlled analysis

The same model was then used with an applied sinusoidal forcing instead of displacement, with the force calculated based upon a known straining in a given deck length. Fig. 5 shows the abutment response with cycles compared to the displacement-controlled case. Despite having similar magnitude, a growing eccentricity developed not consistent with that seen in the field, a limitation of the equal loading and unloading stiffness in the Mohr-Coulomb V constitutive model.

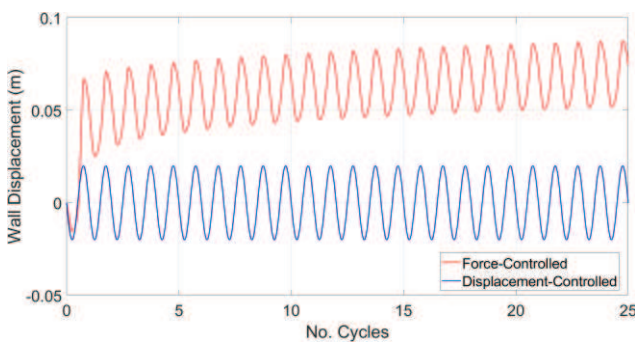

Fig. 5. Force and displacement-controlled comparison.

4 ACTUATION SYSTEM

The mechanical actuator designed to push and pull the wall is shown in Fig. 6. This was fastened to the top of the centrifuge strong box and used to apply constant displacement cycles during the test, reflective of the thermal movement of a bridge deck as it expands and contracts seasonally over its design life.

4.1 System requirements

Displacement and forcing requirements were needed for system design. A deck movement of 0.66 mm was taken (40 mm prototype scale) corresponding to the maximum permitted in U.K. design (BSI, 2020). The forcing requirement was initially found as 8 kN assuming full passive pressures during deck expansion, however from the FE results in Fig. 4 a more realistic value of 4 kN was taken.

The actuation system was controlled using a C++ code cycling the wall between its limits while accounting for system backlash as it passed through 0 load.

5 MODEL TESTING

The model shown in Fig. 6 was taken to 60g in the centrifuge with cyclic movements then applied to the abutment wall. The LVDT and load cell results allow actuator competency to be evaluated.

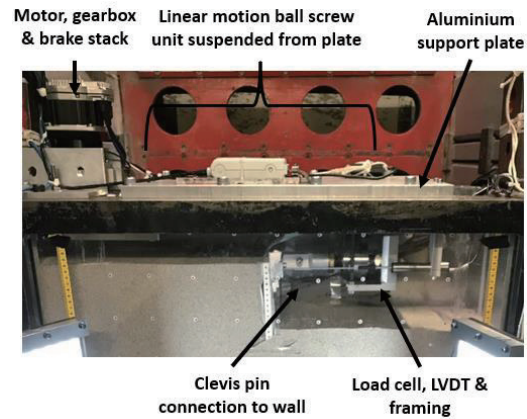

Fig. 6. Actuation system mounted on the strong box.

5.1 Actuator validation

Limits of +/- 0.33 mm were set for 120 cycles in the C++ code — Fig. 7 presents the LVDT and load cell recordings. The LVDT trace shows good consistency in magnitude. Interruptions occurred due to positional corrections to compensate for elastic movement of the actuator frame as the load increased following soil ratcheting. The load cell trace shows a hardening trend hence more corrections were required earlier on.

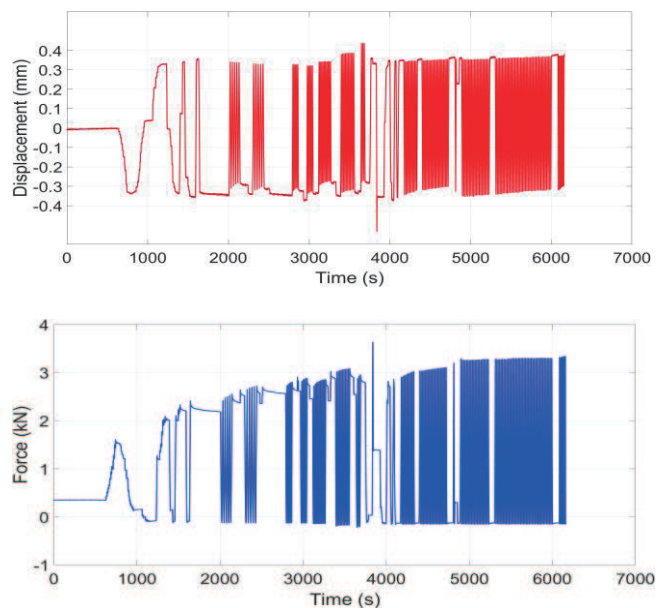

Fig. 7. LVDT and load cell recordings during 60g test.

The load cell recording reflects soil hardening as ratcheting occurred. A magnitude of 3.4 kN towards the end of the cycles closely matched the 4 kN predicted from the numerical model.

The hysteretic behaviour of the system is shown in Fig. 8. Through this, the non-linearity of the system can be observed with a new stiffness backbone for each positional adjustment with elastic deformation.

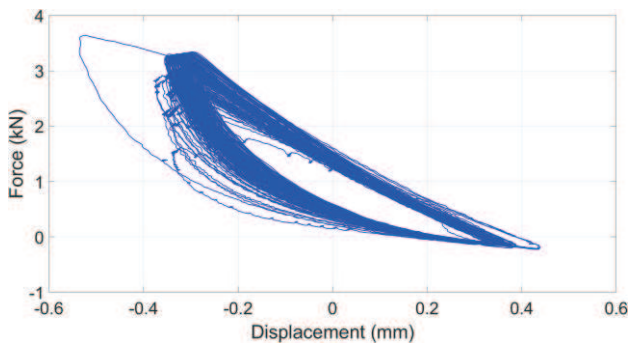

Fig. 8. Hysteretic behaviour during 60g test.

Actuator deformation is undesirable if cyclic repeatability is to be achieved. Rather than stiffening the entire system, the LVDT reading was inputted directly into the control code to guide positioning. Further developments included widening the clevis to ensure no moment transfer, improving the seal between wall and box to prevent sand ingress, and pausing at each cycle extent to observe the soil creep.

5.2 Further testing

The actuator's ability to move at fast speeds was investigated to see if it could simulate high cycle numbers as seen in applications such as wind and wave loading of offshore wind turbines. Fig 9. gives the LVDT response showing a broadly consistent displacement, with frame bending again causing a deviation that can be solved by LVDT-controlled motion inputs.

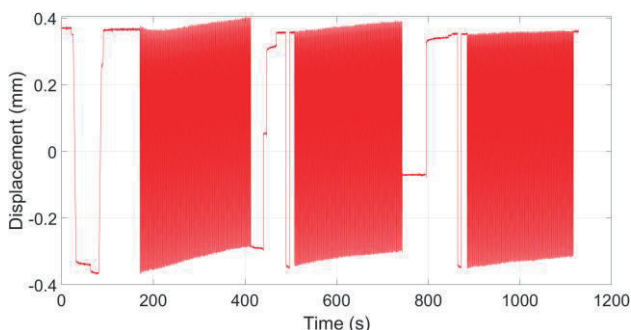

Fig. 9. LVDT recording over 600 cycles at 600 RPM.

6 CONCLUSIONS

A centrifuge model was developed to investigate lateral earth pressure build-up behind integral bridge abutments during deck thermal cycles. Combining

details of model design, numerical modelling, and actuation system testing, the following conclusions can be drawn:

1. Centrifuge modelling allows full-size integral bridges to be simulated to capture influence of soil and structural stiffness on backfill stress ratcheting.
2. FE analysis during model design allows for valuation of expected results and can save considerable resources during actuation system development.
3. The mechanical actuation system described in this paper is capable of replicating integral bridge thermal movements to produce soil strain ratcheting.

Future work will look to capture earth pressure build up behind the abutment during ratcheting, and how the relative stiffness of the soil and structure influences wall bending moments used in design.

ACKNOWLEDGEMENTS

This project was supported by National Highways, GDG Ltd. and EPSRC Centre for Doctoral Training in Future Infrastructure and Built Environment: Resilience in a Changing World (FIBE2 CDT).

REFERENCES

- British Standards Institute. (2020). *PD 6694-1:2011+A1:2020 - Recommendations for the design of structures subject to traffic loading to BS EN 1997-1:2004+A1:2013*. London.
- Card, G. B., & Carder, D. R. (1993). *A literature review of the geotechnical aspects of the design of integral bridge abutments*. Project Report 52.
- England, G. L., Tsang, N. C. M., & Bush, D. I. (2000). *Integral bridges - A fundamental approach to the time-temperature loading problem*. London: Crown Copyright and Thomas Telford Limited 2000.
- Midas Bridge. (2022). Integral Bridges. Retrieved January 20, 2022, from <https://www.midasbridge.com/en/solutions/integral-bridges>
- Sakulich, A. R., & Bentz, D. P. (2012). Increasing the Service Life of Bridge Decks by Incorporating Phase-Change Materials to Reduce Freeze-Thaw Cycles. *Journal of Materials in Civil Engineering*, 24(8), 1034–1042. [https://doi.org/10.1061/\(ASCE\)MT.1943-5533](https://doi.org/10.1061/(ASCE)MT.1943-5533)
- Sandberg, J., Magnino, L., Nowak, P., Wiechecki, M., & Thusyanthan, I. (2020). The integral bridge design concept for the third runway at Heathrow, UK. *Proceedings of the Institution of Civil Engineers: Bridge Engineering*, 173(2), 112–120. <https://doi.org/10.1680/jbren.19.00044>
- Schofield, A. N. (1980). Cambridge Geotechnical Centrifuge Operations. *Geotechnique*, 30(3), 227–268. <https://doi.org/10.1680/geot.1980.30.3.227>
- Springman, S. ., Norrish, A., & Wilkinson, K. (1994). A device for cyclic displacement-controlled actuation of an integral bridge abutment. In C. . Leung, F. . Lee, & T. . Tan (Eds.), *Centrifuge 94* (p. p.163-168). Rotterdam: Balkema.