

INTERNATIONAL SOCIETY FOR SOIL MECHANICS AND GEOTECHNICAL ENGINEERING

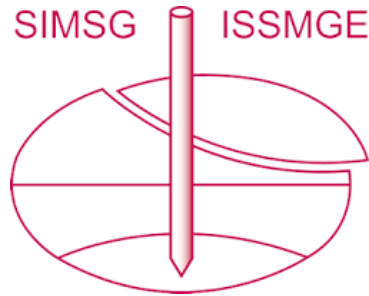

This paper was downloaded from the Online Library of the International Society for Soil Mechanics and Geotechnical Engineering (ISSMGE). The library is available here:

<https://www.issmge.org/publications/online-library>

This is an open-access database that archives thousands of papers published under the Auspices of the ISSMGE and maintained by the Innovation and Development Committee of ISSMGE.

Seismic Response of Floating Tunnel Shafts

J. M. Mayoral¹, N. Sarmiento² and E. Castañon³

ABSTRACT

There is a lack of information regarding the seismic response of tunnel shafts. Seismic-induced stresses in the shaft do not only depend on the ground motion and the soil characteristics but also are affected by the relative stiffness between the soil and the shaft structure. In this paper, a numerical study of the seismic response of typical tunnel shafts commonly used in Mexico City drainage systems is presented. The work is aiming at establishing the controlling design seismic parameters of the shaft. It is assumed that the shafts have a varying depth from 22 to 34m, and external diameters ranging from 12 to 16m, and are located in the very soft high plasticity clay of the former Texcoco Lake located in the surroundings of Mexico City valley, which exhibits low strength and high compressibility. Series of 3D finite differences models were developed in order to simulate the dynamic response of shafts, subjected to a typical subduction earthquake scenario, generated in the Pacific Coast, developed for a return period of 475 years. The ground motion was deconvolved to the base of the soil deposit, and applied to the 3D models as an acceleration time history and quiet boundaries were used in order to avoid reflection of propagating waves back into the model. From the results gathered from this study insight was gained regarding the seismic response of shafts.

Introduction

Failures observed in hydraulic underground strategic infrastructure during recent seismic events such as Kocaeli and Duzce, 1999; Chi-Chi, 1999 and Niigata, 2004 earthquakes have clearly shown that the seismic behavior of these structures is far from being fully understood. In particular, there is a lack of information regarding the seismic response of floating shafts. This is particularly important when considering large return periods for the seismic event (e.g. 475 years for the Operating Basis Earthquake, and 2475 years for the Maximum Credible Earthquake), these seismic demands, combined with the large ground movement amplifications expected to occur in the high plasticity clays found in the Mexico City valley, which exhibit a very large linear range in their modulus degradation and damping curves, should be taken explicitly during the shaft seismic design. Seismic loading acting upon a soil-shaft system is the result of the interplay of earthquake incoming waves with the structure stiffness. In this paper, sets of three-dimensional finite difference models were developed in order to simulate the dynamic response of shafts, subjected to a typical subduction earthquakes scenario, generated in the Mexican Pacific Coast, developed for a return period of 475 years. The ground motions were deconvolved to the base of the soil deposit, and applied to 3D models as an acceleration time history and quiet boundaries were used in order to avoid reflection of propagating waves back into the model.

¹Researcher Institute of Engineering, UNAM, Mexico City, Mexico, JMayoralV@iingen.unam.mx

²Engineering Researcher Institute of Engineering, UNAM, Mexico City, Mexico, NSarmientoS@iingen.unam.mx

³Graduate student Institute of Engineering, UNAM, Mexico City, Mexico, ECastanonL@iingen.unam.mx

From the results gathered herein, a better understanding of the factors controlling the seismic response of shafts was archived.

Subsoil Conditions

Typical subsoil conditions found at the former Texcoco Lake has been studied by several researchers [Mayoral et al. (2008a), Osorio and Mayoral, (2013) and Mayoral et al. (2014)], commonly the soil profile at this zone presents a desiccated crust of clay at the top extending up to a depth of 1.0m, which is underlain by a soft clay layer approximately 38 to 66m thick, with interbedded lenses of sandy silts and silty sands. The plasticity index ranges from 87 to 293%. Underneath this elevation, a competent layer of very dense sandy silt is found. The distance from the National University of Mexico, CU, to the polygon center that encloses the studied area is approximately 25.90km. The region studied is instrumented with four seismic stations, TXSO, TXS1, TXS2 and TXCH. A fifth station used in the analysis, TXRC, is located to the east, on a rock outcrop, about 19.20km (Fig. 1) away from the studied site.

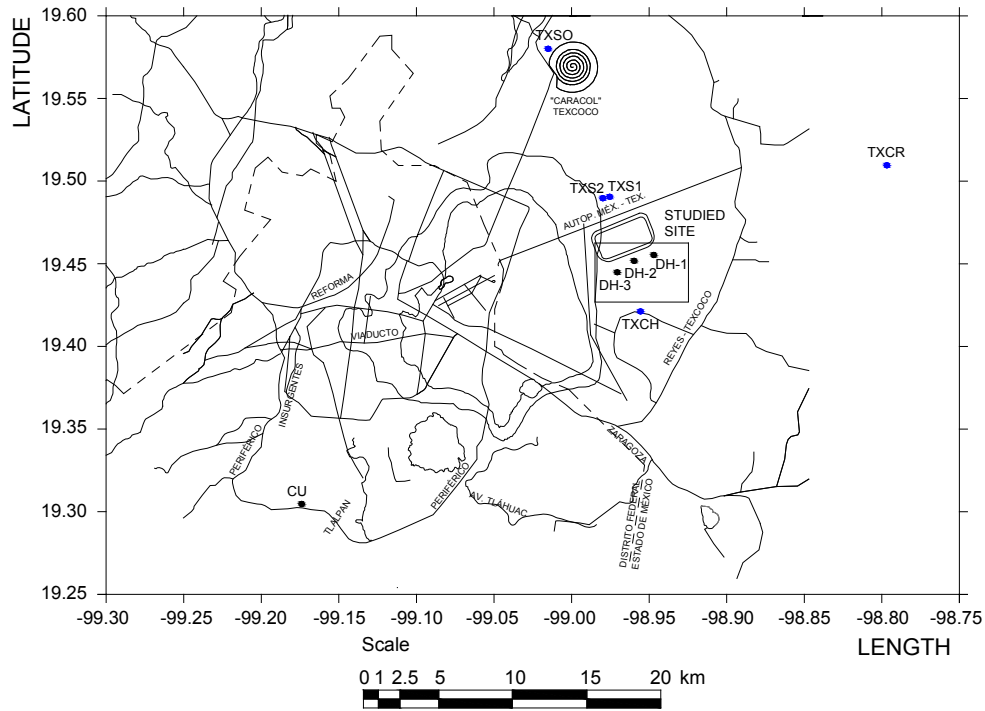

Figure 1. Location of the studied area

Shear Wave Velocity Determination

A generic shear wave velocity, V_s , profile have been established based on research conducted in the area mainly comprised by down-holes tests and ambient noise measurements [Mayoral et al. (2014)], and empirical approaches based on empirical relationships between the tip cone penetration resistance and the shear wave velocity, V_s [Romo and Ovando (1991)]. The idealized geotechnical section for analysis included herein is presented in Fig. 2, which also shows the shear wave velocity distributions with depth obtained from down-hole tests, DH.

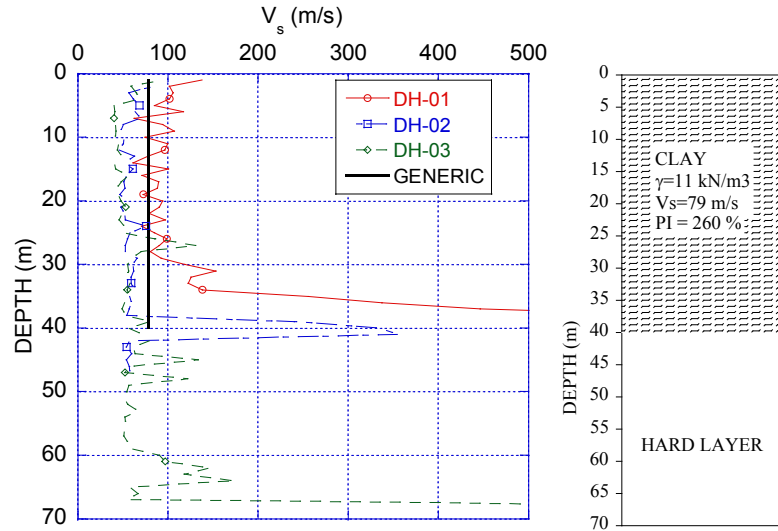

Figure 2. Generic profile, and shear wave velocity profiles measured from down hole-tests, DH

Dynamic Properties

Modulus degradation and damping curves can be obtained through laboratory testing conducted in undisturbed soil samples, or empirical models function of soil type and other variables. In this research, due to the lack of experimental data, the empirical model proposed by Darendeli and Stokoe (2001), were used to generate modulus degradation and damping curves, which take into account confining pressure effects, σ' , plasticity index, PI, over consolidation ratio, OCR, the frequency of loading, f , and the number of loading cycles, N .

Seismic Environment

The uniform hazard spectrum determined to characterize the seismic environment for the subduction seismogenic zone of the Mexican pacific coast, was developed at the same location as the rock station TXCR, at about 18.70 km from the site, to be able to compare it directly with measured responses. As it is well known, the uniform hazard spectra, UHS, is a representation of the relationship between the natural vibration period, T , and spectral acceleration, S_a , for a given exceedance probability associated with a return period. Uniform hazard spectra for return periods 125, 250, 475, 2475 years were obtained from the seismic hazard curves, see Fig. 3a. For the study presented here in, only the corresponding to 475 years was considered (Fig. 3b.). Note that this spectrum defines the seismic environment of the area. Therefore, it was used as input motion during the site response analyses.

Synthetic Acceleration Time History

To develop time histories which response spectra reasonably match the design response spectrum, the selected (recorded) time histories were modified using the method proposed by Lilhanand and Tseng (1988) as modified by Abrahamson (1993). This approach is based on a modification of an acceleration time history to make it compatible with a user specified target spectrum. The adjustment of the time history can be performed with a variety of different

modification models. In doing so, the long period non-stationary phasing of the original time history is preserved. The 5% damped response spectra calculated for the modified time histories are compared. The corresponding response spectrum is shown in Fig. 3b, for which corresponds to a return period of 475 years. It can be seen that the response spectra calculated from the modified time histories reasonably match the target spectrum.

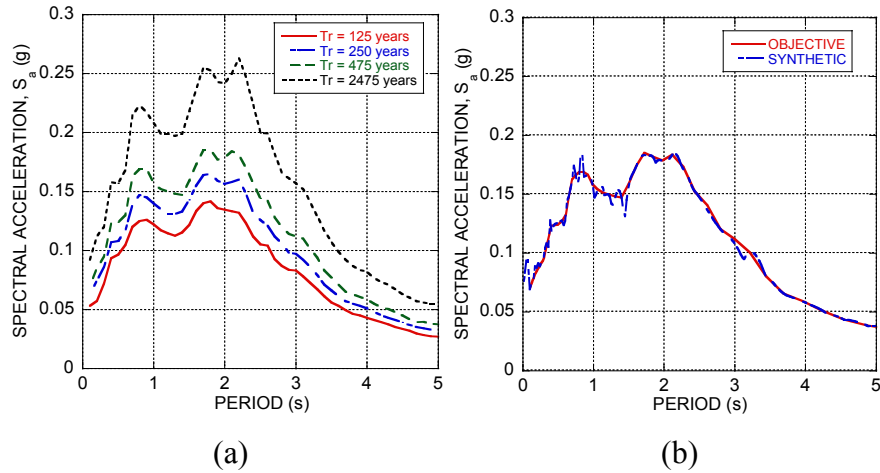

Figure 3. Objective (a) and synthetic (b) ground motions response spectra

Site Response Analysis

The computer code SHAKE [Schnabel et al. (1972)], which solves the wave equation for SH waves propagating vertically in the frequency domain, was used for obtaining equivalent linear properties of the free field. Equivalent linear properties were deemed appropriate to represent soil nonlinearities, considering the high plasticity exhibited by the clay at the site. This is supported by the fact that there is not a significant enlargement of the predominant period or attenuation of the spectral ordinates observed in response spectra of recordings registered at station TXSO for events with M_s larger than 5, even for the destructive 1985 event. The analysis is done in the frequency domain, and, therefore, for any set of properties it is a linear analysis.

Seismic Soil-Structure Interaction, SSSI, Analysis

The seismic analyses were carried out with 3-D finite difference models developed with the program FLAC^{3D}. The free field response obtained with FLAC^{3D} was calibrated against the results obtained with the program SHAKE, which in turn, has been extensively calibrated against theoretical and experimental data. Figure 4 shows a comparison between the acceleration time histories computed at point A (see Fig. 6) with both computer programs. The equivalent linear properties derived from SHAKE were used in the FLAC^{3D} model. An elasto-plastic Mohr–Coulomb model was selected to represent the stress–strain relationship for soils. Thus, the time domain analysis is linear elastic until the soil reaches the failure condition. This assumption was considered appropriate based on the fact that due to the high plasticity of the clay assumed in this research, low to moderated soil stiffness degradation and damping increase are expected to occur. Absorbing transmitting boundaries were added at the base of the meshes, whereas free field boundaries were placed at the lateral edges. Raleigh damping was employed to set the

equivalent linear damping of the soil in the model, at the fundamental frequency of each shaft-soil system approximately, which for the cases analyzed ranged from 1 to 1.2 Hz. As can be seen, there is a very good agreement between both results. The shaft was modelled with shell elements. This allows obtaining displacements, as well as shear forces, bending moments and axial forces at the tunnel shaft (Fig. 5). The shaft wall thickness is 0.80m. The damping of these structural elements is 5%. The concrete properties are compiled in Table 1. The model base is a square four times the shaft diameter, D.

Table 1. Concrete properties used in the analysis

Parameter	Value	Units
Strength at 28 days, f'_c	35	MPa
Young modulus at 28 days, E_c	26,000	MPa
Poisson ratio, ν_c	0.2	-

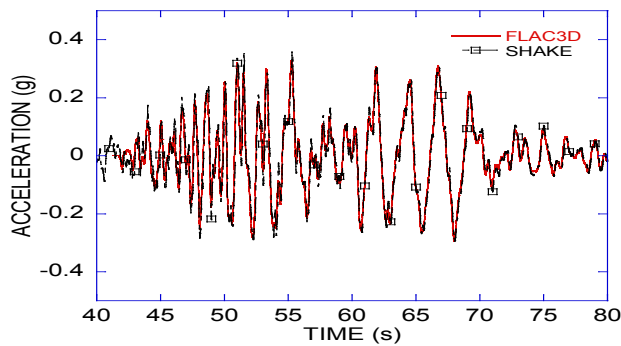

Figure 4. Acceleration time history computed at the surface with the programs SHAKE and $FLAC^{3D}$

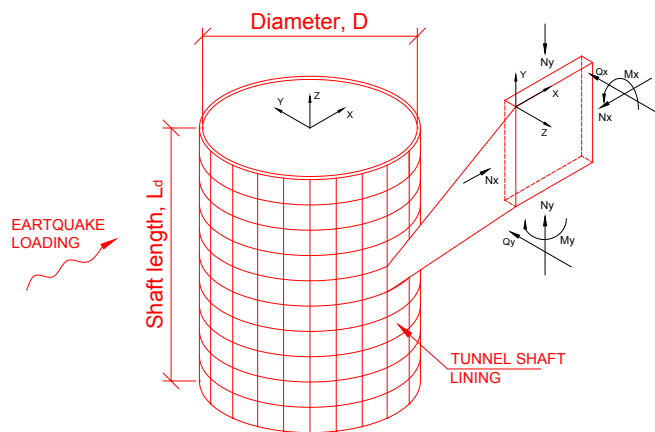

Figure 5. Bending moments, M , normal forces, N , and shear forces, Q , and global coordinate system

The model depth is equal to the soil deposit depth, which takes values of 30m, 40m and 60m (Fig. 6). The calculation is based on the explicit finite difference scheme, to solve the full equations of motion, using lumped grid point masses derived from the real density of surrounding zones. This formulation can be coupled to the structural element model, thus permitting analysis of soil structure interaction.

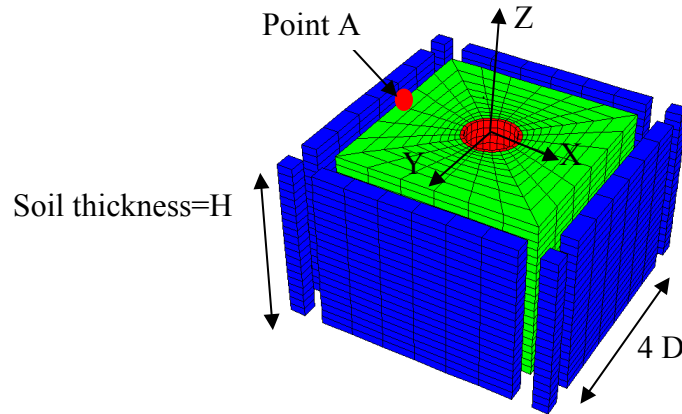

Figure 6. Tridimensional finite difference model and global coordinate system

The parameters H , L_d , D and wall thickness of the tunnel shaft, t , were varied as presented in Table 2.

Table 2. Values considered for each parameter in the parametric study

H (m)	L_d (m)	D (m)	t (m)
30	20	12	0.6
40	24	14	0.8
60	28	16	1
	32		

Tunnel Shaft Seismic Response

The seismic response of the tunnel shaft was obtained in terms of displacements, bending moments, normal forces and shear forces acting on the shaft for each soil deposit depth considered. Figures 7 show the distribution of the maximum responses with depth, along with the envelopes and mean plus one standard deviation values for the case of $H=40\text{m}$ and all the tunnel shaft lengths, which occur in the direction of loading (i.e. x). The shaft depths, L , were normalized with respect to the actual tunnel shaft lengths, L_d . The actual tunnel shaft displacements are normalized with respect to the maximum free field displacement. The bending moments, normal forces and shear forces were normalized with respect to the corresponding maximum static values. The depths are normalized with respect to each tunnel shaft length. Figure 9 shows a summary of all the envelopes corresponding to the soil thickness 30, 40 and 60 m. It can be noticed that the shaft moves almost as a rigid body for a soil deposit 30 m depth.

However, it shows a curvature that goes from slightly to pronounce for 40 m to 60 m respectively. This fact is due to the magnitude and distribution of the maximum displacements that undergo the free field during the seismic event (Figure 8), and its interaction with the tunnel shaft. As can be seen, in all cases the computed seismic bending moments fluctuated from 7 to 12 % of the maximum static value, seismic normal forces ranges from 5 to 8% of the maximum static value, and seismic shear forces varies from 5% to 8%. In all cases the maximum values are presented at a depth $L=0.2 L_d$ for the seismic bending moments, and at a depth of $0.5 L_d$ for normal forces, and at $1 L_d$ (base of the shaft) for shear forces.

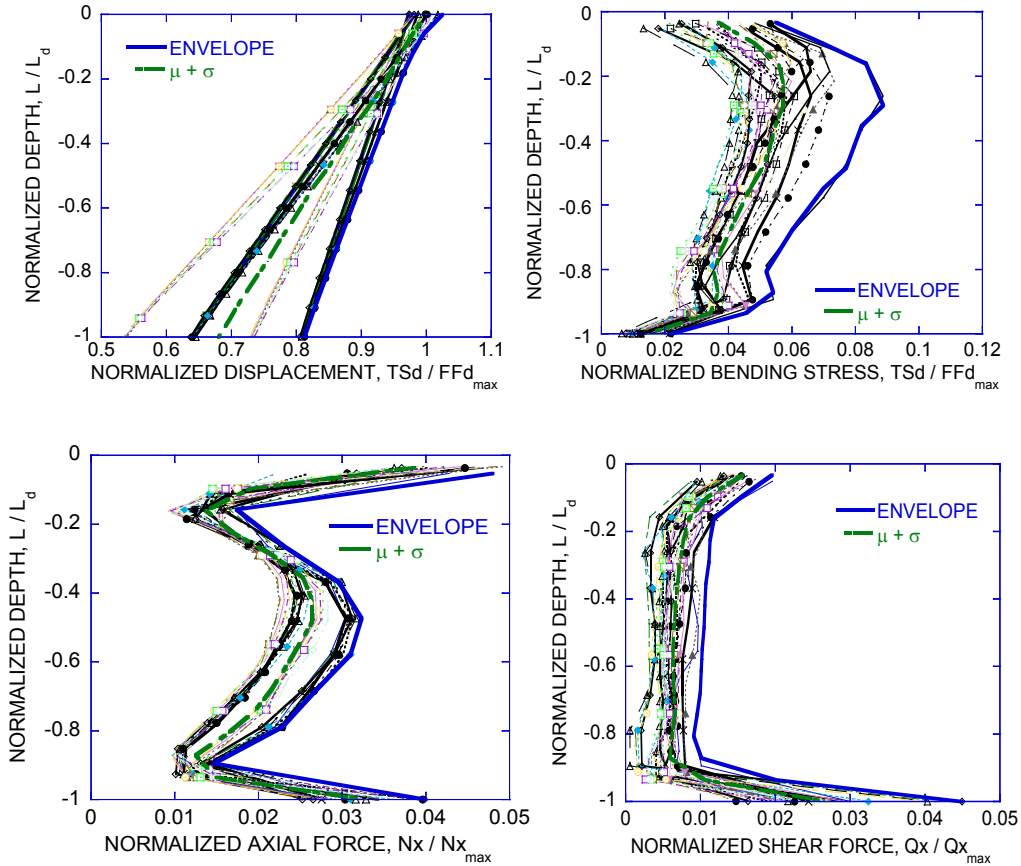

Figure 7. Normalized maximum shaft displacements, TS_d , bending moments, M_x , normal forces, N_x , and shear forces, Q_x along the normalized shaft depth, L/L_d , for a soil deposit 40m depth

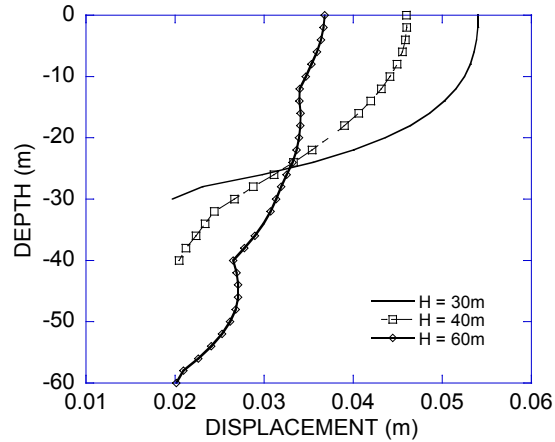

Figure 8. Maximum displacements at the free field for soil deposit depths of 30m, 40m, and 60m

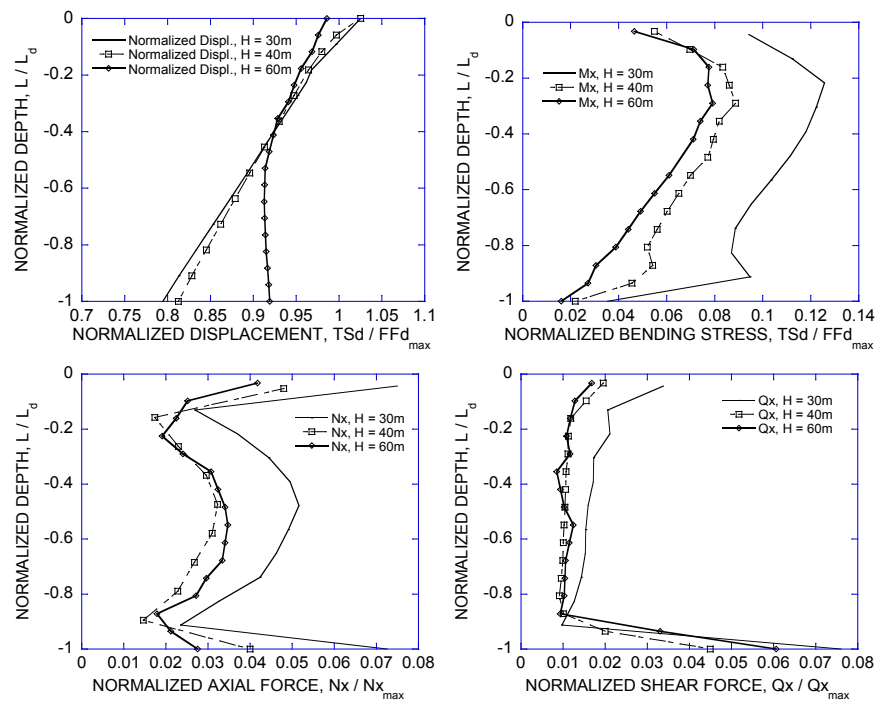

Figure 9. Envelopes of maximum TS_d , M_x , N_x , and Q_x for soil deposit depths of 30, 40, and 60m

Conclusions

A proper assessment of seismic-induced stresses developed in a shaft during a strong ground motion is a key element during the design of hydraulic underground strategic infrastructure. In particular, in soft clay deposits it can be seen that the shaft behaves mostly like a rigid body, for $H=30$ and 40 m, due to its higher relative stiffness with respect to the surrounding soil. Thus, important relative movements are generated between the soil and structure, which in turn lead to stresses in the shaft. As can be seen, in all cases the computed seismic bending moments

fluctuated from 7 to 12 % of the maximum static value, seismic normal forces ranges from 5 to 8% of the maximum static value, and seismic shear forces varies from 5% to 8%. In all cases the maximum values are presented at a depth $L = 0.2 L_d$ for the seismic bending moments, and at the upper portion of the shaft (i.e. around $0.1 L_d$) for axial forces, and at L_d (base of the shaft) for shear forces.

References

- Abrahamson, N. A., 2000. State of the practice of seismic hazard evaluation. *Proceedings of GeoEng 2000*, Melbourne, 19-24 November, Vol. 1, pp. 659-685
- Darendeli MB, Stokoe KH. *Development of a new family of normalized modulus reduction and material damping curves*. Geotechnical Engineering Report GD01-1, University of Texas at Austin, Austin, 2001.
- Lilhanand K. y Tseng W. S., 1988. Development and application of realistic earthquake time histories compatible with multiple damping response spectra. *Proceedings of the 9th World Conference on Earthquake Engineering*, Tokyo, Japan, Vol. II, pp 819-824
- Mayoral, J. M., Romo, M. P. y Osorio, L., 2008a. Seismic parameters characterization at Texcoco lake, Mexico. *Soil Dynamics and Earthquake Engineering*, Volume **28**, Issue 7, Pages 507-521, July.
- Mayoral, J. M. y Osorio, L., 2013. Seismic microzonation for the northeast Texcoco lake area, Mexico. *Soil Dynamics and Earthquake Engineering*, Volume **48**, Issue 7, Pages 252-266, Jan.
- Ovando, E. y Romo, M. P., 1991. Estimación de la velocidad de ondas S en la arcilla de la ciudad de México con ensayos de cono, *Revista Sismodinámica*, **2**, 107-123
- Schnabel PB, Lysmer J, Seed HB. *SHAKE: a computer program for earthquake responder analysis of horizontally layered Sites*; College of Engineering, Report No. EERC 72-12, University of Berkeley, CA, 1972.