

INTERNATIONAL SOCIETY FOR SOIL MECHANICS AND GEOTECHNICAL ENGINEERING



This paper was downloaded from the Online Library of the International Society for Soil Mechanics and Geotechnical Engineering (ISSMGE). The library is available here:

<https://www.issmge.org/publications/online-library>

This is an open-access database that archives thousands of papers published under the Auspices of the ISSMGE and maintained by the Innovation and Development Committee of ISSMGE.

CORRECTIONS

(Volume 1)

Page 137: The following paragraph should be added:

In the undrained creep test illustrated in Fig.8, the deviator stress was increased temporarily to induce rapid strain. It was then decreased to the point where the stress ratio was identical to that prior to the increase and maintained at this level for some time. It will be seen that the rate of increase of both the pore pressure and the axial (or shear) strain with time was reduced as a result of the rapid strain, but eventually both curves became coincident with curves which appear to be a continuation of the original curves. These results complement those in Fig. 3 and lend further support to the contention made in the paper that the internal resistance to shear increases as a function of previous shear strain rather than as a function of time.

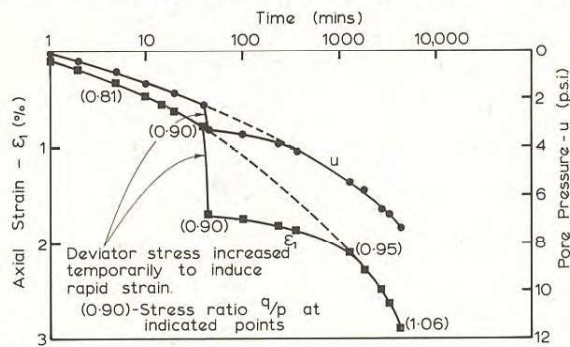

Fig. 8. - Effect of Transient Increase in Deviator Stress on the Ensuing Creep Behaviour.

Page 220: The caption to Fig. 7 (a) should read "Radial ridges (F)".

Page 302: Fig. 7, the distance between the lines $u = 0$ and $u = 0.3 h$ should be shown as 50 feet. This dimension had been omitted.

Page 305: Section X(d) "RESULTS", first paragraph, second last line, $F = 1.6$ should read $F = 2.6$.

Page 317: "(e.g. joint 3 in Fig. 4)" should be deleted.

Pages 406 and 407: To facilitate evaluation of the terrain components the horizontal rows of the table on p. 407 should align with those of the table on p. 406.

Page 425: In some of the columns of Tables II and III there should be < and > signs.

TABLE II.

Grade IV	The P.I. should be < 10 rather than 10 as shown. The % finer than 2 microns should be < 15 rather than 15.
Grade VI	The P.I. should be > 30 rather than 30 as shown. The % passing the 200 sieve should be > 80 rather than 80.

TABLE III.

Grade IV	The compression index should be < 0.1. The preconsolidation pressure > 20.0 T/ft ² The friction angle > 35°.
Grade VI	The preconsolidation pressure should read < 10 T/ft ² The friction angle should be < 15°.

Page 273: (i) Fig. 3 is incorrect and should be replaced by the corrected version shown below.

(ii) The last sentence in the first column should now be deleted.

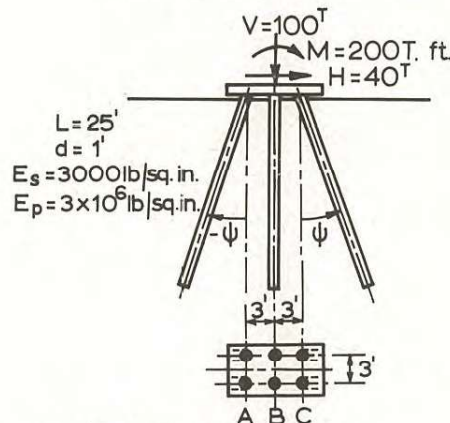

(a) $\psi = 0$ (vertical piles)

Piles	V (T)	H (T)	M (T.ft)	ρ_v (in.)	ρ_h (in.)	θ (rad.)
A	-1.63	9.09	-10.33	.202	.178	.00235
B	12.50	1.82	-1.65	.287	.178	.00235
C	39.13	9.09	10.33	.372	.178	.00235

(b) $\psi = 15^\circ$ (battered piles)

Piles	V (T)	H (T)	M (T.ft)	ρ_v (in.)	ρ_h (in.)	θ (rad.)
A	1.98	11.54	-13.50	.165	.124	.00203
B	12.67	5.85	-3.75	.239	.124	.00203
C	35.35	2.61	17.12	.313	.124	.00203