

INTERNATIONAL SOCIETY FOR SOIL MECHANICS AND GEOTECHNICAL ENGINEERING



This paper was downloaded from the Online Library of the International Society for Soil Mechanics and Geotechnical Engineering (ISSMGE). The library is available here:

<https://www.issmge.org/publications/online-library>

This is an open-access database that archives thousands of papers published under the Auspices of the ISSMGE and maintained by the Innovation and Development Committee of ISSMGE.

The paper was published in the proceedings of the 7th Australia New Zealand Conference on Geomechanics and was edited by M.B. Jaksa, W.S. Kaggwa and D.A. Cameron. The conference was held in Adelaide, Australia, 1-5 July 1996.

Three-Dimensional Analysis of Saturated Soil Foundations for Sea Port Constructions

K. Sh. Shadunts

Ph. D.

Professor, Chairman, Kuban State Agrarian University, Russia

V. V. Podteikov

Ph. D.

Associate Professor, Kuban State Agrarian University, Russia

Summary This work contains some information about sea constructions foundations design. Calculations of the soil foundation are based on Mindlin's fundamental solution for the elastic isotropic half-space. Realisation by PC was done with the use of the boundary element method. All the non-linear and rheological processes in the soil mass are simulated with the help of fictitious volumetric forces. For the volumetric forces calculations in the areas, where soils behaviour is non-linear, different theories were used. Fictitious forces, which cause the filtration consolidation process, are determined according to Darcy's law, rheological processes are described by the formulas, obtained from the results of three-dimensional tests.

1. INTRODUCTION

The Russian coast of the Sea of Azov consists mainly of soft silty, sandy-loam and clay soils. The structure of the foundation is "a puff-pastry" in which the silt layers alternate with the layers of different sands and coquina. The construction of water-development works changes their natural stressed-strained state. When the load is increased, the settlement of the foundation takes place due to the compaction (consolidation) of the soft silty layers.

Many theoretical scientific works are devoted to the investigation of the consolidation process of water-saturated clay soils. The possibilities granted by the modern personal computers allow to pass from the simplified one-dimensional and flat solutions to the calculations in three-dimensional space in the engineering practice. The worked-out mathematical models make it possible to carry out the calculations taking into account the elastic component, the filtration component and the creep one of the process.

2. DESIGN OF SOIL FOUNDATIONS

The presence of the considerable horizontal loads (the influences of wind and the wave action, the strikes of ships during mooring, the loads caused by the movement of ice) is a peculiarity of the sea water-development works. This work is devoted to a calculation of the consolidation of a foundation of a gravitation drilling platform for oil production on the continental shelf.

2.1 Theory

A rigid rectangular footing on an elastic isotropic half-space is investigated. The calculation of the stressed-strained state (SSS) has been car-

ried out by the authors with the help of the boundary element method (BEM) with the use of Mindlin's fundamental solution.

Mindlin's solution [1] gives the movements and the stresses due to a concentrated force inside the elastic isotropic half-space:

$$u_{ij} = A_u P_j \phi_{ij}(x_k, x_{kp}), \quad i, j, k = 1, 2, 3, \quad (1)$$

$$\sigma_{lj} = A_\sigma P_j \psi_{lj}(x_k, x_{kp}), \quad l = 1, 2, \dots, 6. \quad (2)$$

where

u_{ij} - movement in the i direction at the point (x_1, x_2, x_3) due to the force P acting in the j direction at the point (x_{1p}, x_{2p}, x_{3p}) ,

σ_{lj} - stress in the l direction,

A_u, A_σ - coefficients depending on the physical constants of the elastic medium,

ϕ_{ij}, ψ_{lj} - Mindlin's functions for movements and stresses,

i, j, k, l - directions of the movements, the forces, the coordinate axes and the axes of stresses, accepted in accordance with Figure 1.

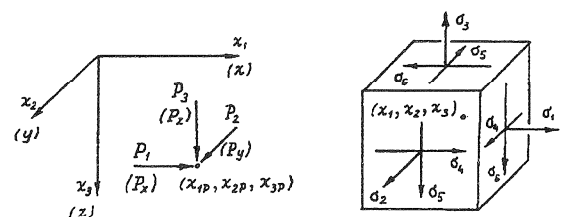

Figure 1. Directions of stresses, movements and forces.

If the formulas (1) and (2) are available, the solution of a contact problem of the theory of elasticity is reduced to the solution of the boundary integral equation of the form [2]:

$$u_i = \int_{\Gamma} u_{ij}^* p_j d\Gamma + \int_{\Gamma} p_{ij}^* u_j d\Gamma + \int_{\Omega} u_{ij}^* b_j d\Omega \quad (3)$$

The following designations are used in the equation (3) (s. Fig. 2):

u_i - movement of a body Ω in the point s as a solid one,

u_{ij}^*, p_{ij}^* - movement and stress in the i direction in the S point of Γ boundary due to the influence of a solitary force in the j direction in the Q point of the Ω body,

p_j, u_j - stress and movement in the Q point of the Γ boundary,

b_j - mass forces in the q point of the Ω body.



Fig. 2. Body Ω with Γ boundary inside half-infinite space

The first integral in the right part of the equation (3) belongs to the part of the boundary where the movements are given; the second one belongs to the part where the stresses are given. If the calculated mathematical model has no boundary conditions in the stresses (lack of the cavities, the slopes, the surfaces changing geometry of the half-space), the second component in the right part of the expression can be omitted:

$$u_i = \int_{\Gamma} u_{ij}^* p_j d\Gamma + \int_{\Omega} u_{ij}^* b_j d\Omega, \quad i, j = 1, 2, 3. \quad (4)$$

In general the mass forces (the own weight of the elastic medium, the inertial force, etc.) can be applied in any point of the half-space which coincidence with the Γ boundary is unnecessary. Besides, the fictitious volumetric forces have been introduced in order to model different types of the foundation non-uniformity, the plastic deformation, the consolidation and the rheologic processes. The fictitious forces do not change the general equilibrium of "a body-border-half-space" system; they cause only the additional deformations modelling a non-linear behaviour of the foundation. The fictitious forces like the mass forces can act in any point of the half-space. But unlike them, there can be six direction of the action of the fictitious forces (s. Fig.1). The forces themselves are the fictitious ones, but the movements and the stresses, caused by them,

are the real ones. Thus, the equation (4) can be re-written:

$$u_i = \int_{\Gamma} u_{ij}^* p_j d\Gamma + \int_{\Omega} u_{ik}^* b_k d\Omega + \int_{\Omega} u_{il}^* f_l d\Omega, \quad (5)$$

where $i, j, k = 1, 2, 3, l = 1, 2, \dots, 6$.

The calculation of the integrals belonging to the equation (5) in the closed form is possible only in some particular cases due to the complication of the expressions under the integral. In engineering practice one resorts to the numerical integration; it will be mentioned in § 2.2. The mass forces are considered to be known. The fictitious volumetric forces are determined as the initial conditions at each step of calculations. The steps are performed both according to the load and the time. A value of an increment of the load (the time) should provide the calculation stability. From the point of view of the non-linear calculations, the calculations of the fictitious volumetric forces are of the greatest interest.

2.1.1. Fictitious Volumetric Forces Modelling a Slip and Breaking Off of Constructions from Foundation

A determination of the unknown p_j stresses acting at Γ boundary is a result of the solution of the equation (5). With respect to the problem being considered Γ is a contact surface of the drilling platform base with the foundation. Therefore, p_j are the contact stresses. In the course of the calculations a result can be obtained in which the contact normal p_3 stresses will have positive (tensive) values. Theoretically such a result is a correct one, but practically, when there is no cohesion, it is impossible. The situation can be improved with the help of the fictitious f_3 forces applied in the direction of the normal p_3 stress. The value of f_3 fictitious forces is determined iteratively.

One more case of the non-linear behaviour on Γ boundary appears when the relation of the contact stresses does not correspond to Coulomb's friction law:

$$\sqrt{p_1^2 + p_2^2} \leq p_3 \operatorname{tg} \varphi + c, \quad (6)$$

where p_1 and p_2 - the contact tangential stresses acting along the x_1 and x_2 axes,

φ, c - inner friction angle and cohesion of the material of the soil foundation.

If the condition (6) is not fulfilled in any region of Γ boundary, the footing slides along the foundation. This process is modelled by the introduction of f_{τ} fictitious volumetric forces in the direction of the tangential stresses p_1 and p_2 . The value of f_{τ} forces is also determined by iteration.

2.1.2 Fictitious Forces Modelling Pore Pressure

As a rule, the sea water-development works design envisages the check of the general stability of the foundation. One can carry out such calculations only under the conditions that for each time both in the period of the construction and the operation the stresses in the soil's skeleton and the pore pressures will be known. In geomechanics the initial pore pressures at any point for two-phase medium are widely accepted as equal to:

$$p_{w0} = \frac{1}{3}(\sigma_1 + \sigma_2 + \sigma_3) \quad (7)$$

The stress at the internal points can be determined by the simple summation:

$$\sigma_i = \int_{\Gamma} \sigma_{ij}^* p_j d\Gamma, \quad i, j = 1, 2, 3, \quad (8)$$

where σ_{ij}^* - stress in the i direction from the solitary force active in direction j on the Γ boundary.

As the pore pressure at one point influence the value of the $\sigma_1, \sigma_2, \sigma_3$ stresses in the soil skeleton at other points, it is possible to calculate the initial pore pressures only by means of iteration.

In the process of the filtration consolidation void water is pressed from the regions with higher excessive pressure to the neighbouring regions. Filtration velocity is determined according to Darcy's law:

$$v_i = c_{pi} \frac{\partial p_{wi}}{\partial x_i}, \quad i = 1, 2, 3, \quad (9)$$

where v_i - filtration velocity in the i direction, c_{pi} - filtration coefficient in the i direction.

The void water volume change at the point in time is expressed as a divergence of velocity vector:

$$\frac{dV}{dt} = s \operatorname{div} v, \quad (10)$$

where s - flow section area.

Then one can calculate the pore pressure change at the point:

$$\frac{dp_w}{dt} = K \frac{dV}{dt} = K s \operatorname{div} v, \quad (11)$$

where K - bulk modulus of deformation equal to

$$K = \frac{E}{3(1-2\mu)}, \quad (12)$$

where E - Young's modulus, μ - Poisson's ratio.

Pore pressure at the point in t time is:

$$p_{wt} = p_{w0} + \frac{dp_w}{dt}(t-t_0), \quad (13)$$

where t_0 - zero time.

Effective stress in the soil skeleton under the filtration consolidation conditions in time is:

$$\sigma_{it} = \sigma_i - p_{wt}, \quad i = 1, 2, 3. \quad (14)$$

Here σ_i - total stress (stress in the skeleton in the absence of void water).

2.1.3 Modelling of Rheological Processes

The creep and the relaxation belong to the rheological processes.

Let's suppose that the consolidation of material of the foundation is determined by the simultaneous passing of two processes: the filtration consolidation and the skeleton creep. The phenomenon of creep takes place due to the increase of the volumetric deformations and the shear ones in time when the constant load takes place. Pore pressures do not influence the value of the shear stresses.

The f_{ci} fictitious volumetric forces modelling the ε_i volumetric deformations and the displacement ones can be determined by means of processing of the results of the laboratory tests of the soils. Processing means the approximation of the experimental "stress - deformation" curves (s. Fig.3) by different functions in order to obtain a dependence of the form:

$$\varepsilon_i = \phi_i(t), \quad i = 1, 2, \dots, 6. \quad (15)$$

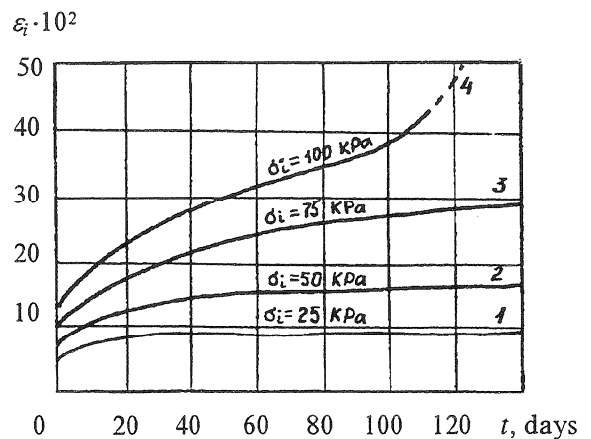

Figure 3. Experimental curves of the shear tests of the clay soils.

In Fig.3 the 1 and 2 curves are the damping ones and are described by a function of the form:

$$\varepsilon_{it} = a - b e^{-\alpha t_i}, \quad i = 1, 2, \dots, 6, \quad (16)$$

where ε_{it} - creep flow in time, a, b, α - constants, t_i - stress action time.

The curve 3 (s. Fig. 3) is not a damping one; it can be approximated by the logarithmic function:

$$\varepsilon_{it} = a + b \ln(\alpha t_i + 1) \quad (17)$$

The curve 4 (Fig. 3) consists of three parts; each part should be approximated by its function.

As in the theory of elasticity the deformations are linear dependent on the load, the (16) and (17) expressions determine the law of the change of the f_{ci} fictitious volumetric forces in time:

$$f_{ci} = A_c (a - b e^{-\alpha t_i}), \quad (18)$$

where A_c - coefficient depending on the physical constants of the elastic medium.

2.1.4 Volumetric Forces when Modelling Spatial Non-Uniformity of Soil Foundation

In practice, the foundations of the works being built are non-uniform both in depth and in plan. It is rather difficult to predict the settlements of such foundations. The precise solutions are possible only in some particular cases. The mathematical modelling of the non-uniform foundations can be carried out numerically with the help of the fictitious volumetric forces using the method of boundary integral equations.

The volumetric forces describing different physical and mechanical properties in some or another region of the foundations are calculated with the help of iteration. At the first step of the iterations the initial deformations are given from the elastic solution. Then, in the zones where the elastic characteristics of material differ from the ones accepted in the calculation model, the f_{ei} fictitious volumetric forces are introduced:

$$f_{ei} = A_i \sigma_i, \quad i = 1, 2, \dots, 6, \quad (19)$$

where A_i - coefficient calculated in the following way:

$$A_i = 1 - \frac{E_i}{E}, \quad \text{if } E_i > E, \quad (20)$$

$$A_i = \frac{E}{E_i} - 1, \quad \text{if } E_i < E, \quad (21)$$

E and E_i - Young's modulus in the calculated model of the foundation and at the given point.

2.1.5 Calculation of Volumetric Forces Describing Plastic Deformations

An achievement of the limiting state at any point of the foundation is a condition of the beginning and the development of plastic deformations. The limiting state can be expressed both in the stresses and in the strains. As a variant, the limiting state coming in the stresses is accepted in the form of Coulomb's strength condition:

$$\tau_o \leq \sigma_o \operatorname{tg} \varphi + c \quad (22)$$

where τ_o and σ_o - shear and normal stress, acting on the octahedron area.

If the condition (22) is not fulfilled at any point of the foundation (if $\tau > \tau_o$), the f_p fictitious volumetric forces modelling the additional (flow) deformations are applied in the τ_o action direction. The value of the volumetric forces is determined according to the formula:

$$f_p = n (\tau / \tau_o - 1), \quad (23)$$

where n - coefficient depending on the direction cosines of the principal planes.

2.2 Numerical Realisation

The boundary integral equation solution (5) in the closed form is a difficult task which can be solved only for simple surfaces and boundary conditions. That's why the numerical approach is used for such equations. The main steps of such approach, called a boundary element method, consists of the following [2]:

1) the Γ boundary is digitized with the help of a series of the J elements, on which the stresses are considered to be constant;

2) the equation (5) is written for each direction of the movement at the S nodal point of the Γ boundary, and the integrals are calculated numerically. As a result, we have a set of J linear algebraic equations, in which J nodal forces are the unknown quantities;

3) the boundary conditions are applied, and the set of the equations is solved with the help of the usual methods.

It should be noted that besides the J nodal forces, when the contact problem is being solved, six movements of the body as a solid one will be the unknown quantities. These movements can be found if six equations of equilibrium are added to the set.

Then the following can be written for i direction at the point S of the boundary Γ :

$$u_i = \sum_{j=1}^J \left(p_j \int_{\Gamma} u_{ij}^* d\Gamma \right) + \sum_{k=1}^K \left(b_k \int_{\Omega} u_{ik}^* d\Omega \right) + \sum_{l=1}^L \left(f_l \int_{\Omega} u_{il}^* d\Omega \right), \quad (24)$$

where K - quantity of the discrete mass forces, L - quantity of the discrete fictitious volumetric forces (s. Fig 4).

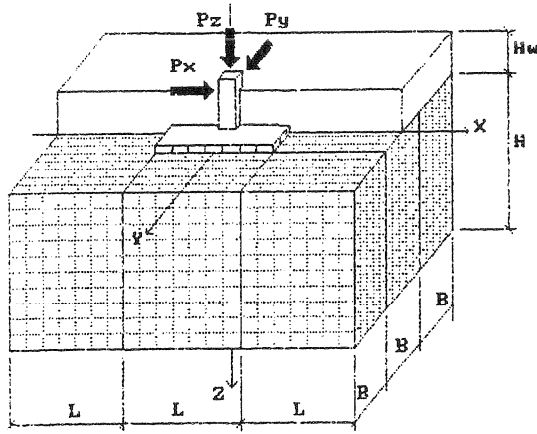

Figure 4. Γ boundary and Ω body digitization.

Let us replace the integrals in equation (24) by the summation:

$$u_i = \sum_{j=1}^J \left(p_j \frac{1}{M} \sum_{m=1}^M u_{ijm}^* \right) + \sum_{k=1}^K \left(b_k \frac{1}{N} \sum_{n=1}^N u_{ikn}^* \right) + \sum_{l=1}^L \left(f_l \frac{1}{N} \sum_{n=1}^N u_{iln}^* \right), \quad (26)$$

where M - digitization degree of integral numerical computation over a boundary element surface, N - the same over a mesh volume of the Ω body in the vicinity of a node of the mass (fictitious) forces.

A little manipulation yields:

$$u_i - \sum_{j=1}^J (U_{ij}^* p_j) = \sum_{k=1}^K (U_{ik}^* b_k) + \sum_{l=1}^L (U_{il}^* f_l), \quad (25)$$

where:

$$U_{ij}^* = \frac{1}{M} \sum_{m=1}^M u_{ijm}^*, \quad U_{ik}^* = \frac{1}{N} \sum_{n=1}^N u_{ikn}^*, \\ U_{il}^* = \frac{1}{N} \sum_{n=1}^N u_{iln}^*. \quad (27)$$

Thus, the solution of the equation (5) with the help of the BEM means the solution of the set of the linear algebraic equations (26) with the addition of the equilibrium equations on the

boundary. In order to automatize the computation the authors have worked out "PLATFORM" program which has been used for the design of the drilling platforms for oil production on the continental shelf.

2.3 Results

Some results of the computations according to "PLATFORM" program are given in Figures 5-7. The physical and mechanical characteristics of the foundation soils and the existing loads are the initial data for the work.

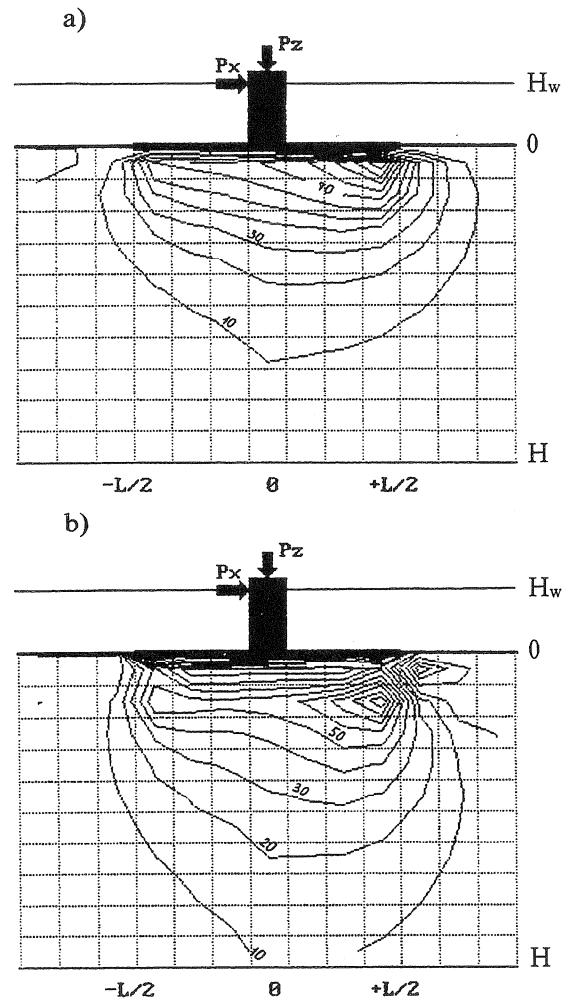

Figure 5. Pore pressure (a) and σ_3 stress (b) in soil skeleton in the plane $x_2 = B/2$ at $t = 20$ days.

2.3 CONCLUSIONS

1. The fictitious volumetric forces modelling the volumetric deformations and the shear strain can be determined by means of processing of the results of the laboratory tests of the soils.
2. As in the theory of elasticity the strains are linear dependent on the load, equations (16) and (17) determine the law of the change of the fictitious volumetric forces with time.

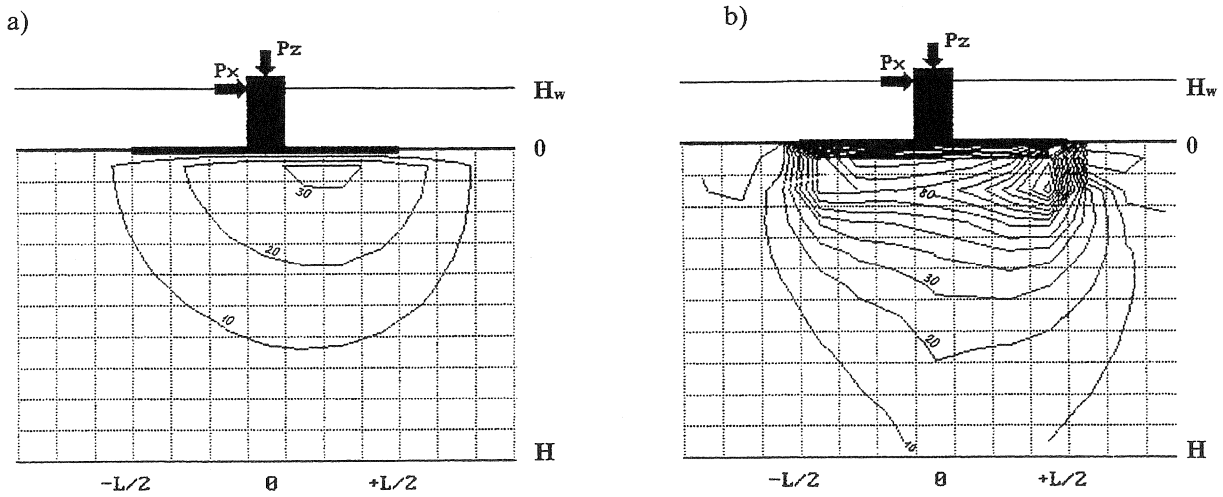

Figure 6. Pore pressure (a) and σ_3 stress in soil skeleton (b) in the plane $y = B/2$ at $t = 360$ days.

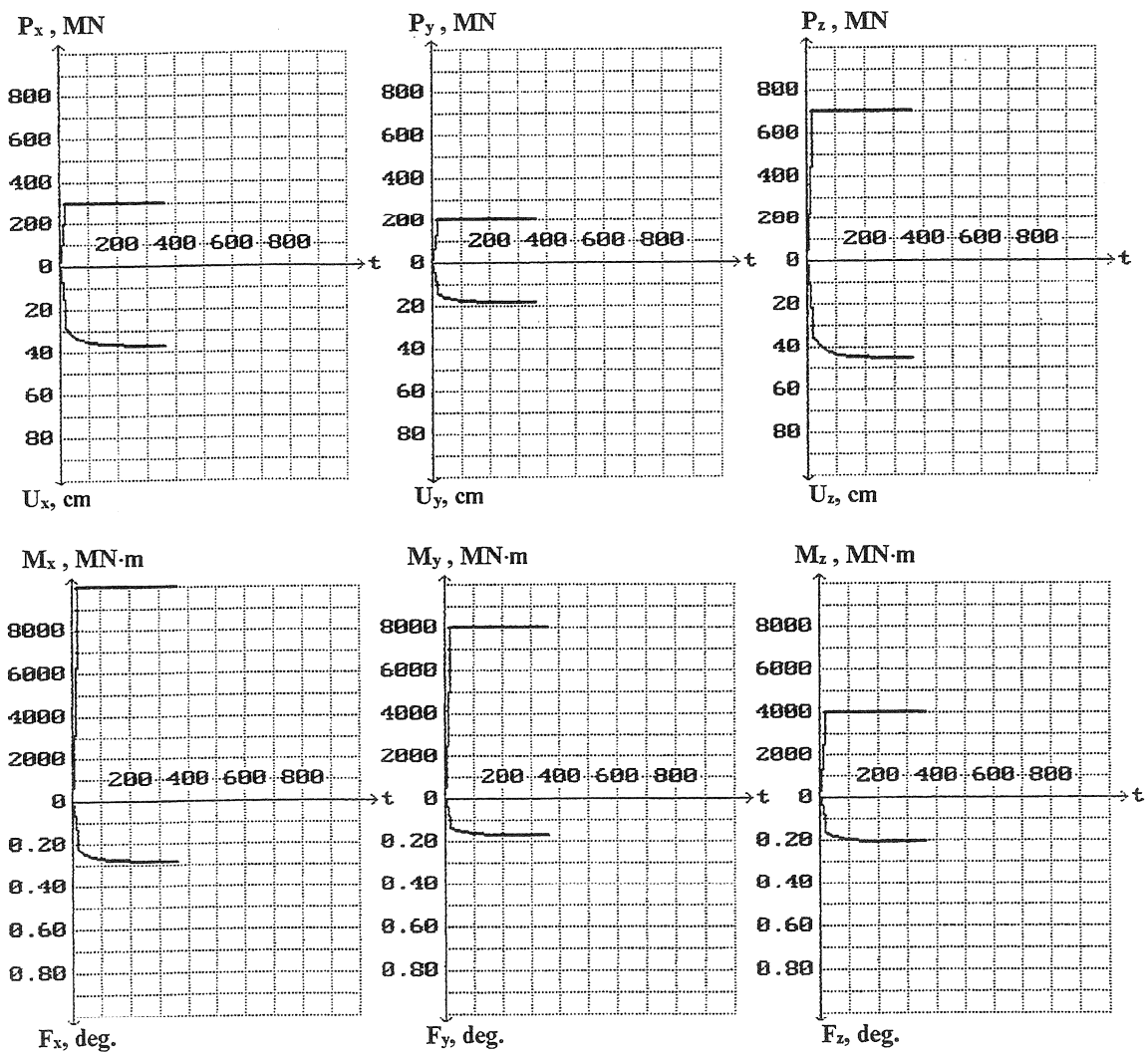

Figure 7. Settlements (U) and axes rotations (F) of the drilling platform in time.

4. REFERENCES

[1] Mindlin, R. D. (1936). Force at a Point in the Interior of Semiinfinite Solid. *Physics*, 7, pp 195-202

[2] Telles, J. C. F. (1983). *The Boundary element Method Applied to Inelastic Problems*, Springer-Verlag, Berlin Heidelberg New York Tokyo, 150p